

# KNX System arguments

KNX Association

## Table of Contents

1	KNX Association: A Brief Outline .....	3
2	Goals of the KNX Association .....	4
3	KNX: the Technology .....	5
4	KNX System specification .....	6
4.1	KNX Media .....	6
4.2	Areas of application for the various media.....	7
4.2.1	Types of Configuration .....	7
5	KNX Interworking .....	8
6	Success Rate.....	9
7	The Advantages of KNX.....	9
8	Selling the benefits.....	11

## 1 KNX Association: A Brief Outline

KNX Association has been set up in 1999 with headquarters in Brussels as the merger between three former European associations promoting intelligent homes and buildings, i.e.:

- ✚ BCI (France) promoting the Batibus system;
- ✚ EIB Association (Belgium) promoting the EIB system;
- ✚ European Home Systems Association (Holland) promoting the EHS system.

KNX Association has the following goals:

- ✚ definition of a new truly open standard 'KNX' for intelligent homes and buildings;
- ✚ establishing the KNX Trademark as a token for quality and multi-vendor interworking;
- ✚ establishing KNX as the European and worldwide standard.

As long as needed, KNX Association also offers support for the legacy systems Batibus, EIB and EHS, including certification according to these previous standards. As EIB is backward compatible to KNX, most devices can be labelled both with the KNX as well as the EIB logo.

## 2 Goals of the KNX Association

- 
- Definition of **testing and quality standards** via working and expert groups (KNX Specifications)
  - **Technical Hotline** for manufacturers developing KNX compatible devices
  - Issue of **KNX Trademark** on the basis of specifications through KNX Certification
  - National and International **Standardization** Activities
  - Promotion of **training** measures by certification of training centers
  - **Promotional activities** (web site, trade fairs)
  - Encouraging forming of **national groups**
  - **Scientific Partnership** for Technical institutes
  - Rest specification work/promotion/certification of **legacy systems**

**Figure 1: Goals of the KNX Association**

KNX Association consisted of 9 members when it was founded: this number has meanwhile increased to more than 300 (situation November 2012), including companies that were before not a member in any of the legacy associations. These companies represent more than 80% of the European market for installation devices and white goods. The current membership list is available at any time under [www.knx.org](http://www.knx.org). As far as the legacy associations is concerned,

- ✚ the Batibus Club was transformed into the national group KNX France;
- ✚ KNX Association has taken over the development and sale of the KNX software packages from EIBA Brussels. This amongst others includes the ETS™ (Engineering Tool Software) (see later);
- ✚ EHSA was integrated in the KNX structures.

At the end of 2003, the KNX Standard was approved by CENELEC (European Committee of Electrotechnical Standardisation) as the European Standard for Home and Building Electronic Systems as part of the EN 50090 Series. The KNX Standard was also approved by CEN (EN 13321-1 for media and protocol and EN 13321-2 for KNXnet/IP). At the end of 2006, KNX was also approved as a world standard (ISO/IEC 14543-3). In 2007, the Chinese translation of the international standard achieved GB/Z status as GB/Z 20965. KNX is also approved in the USA as ANSI/ASHRAE 135.

### 3 KNX: the Technology

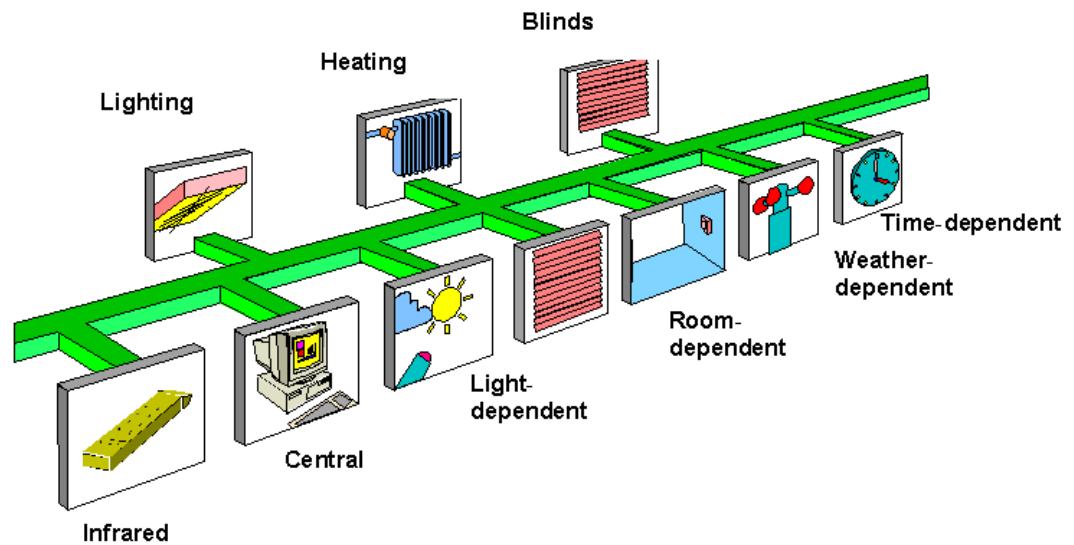

**Figure 2: KNX - the Technology**

In the case of the most widely used medium “Twisted Pair 1”, a control cable is laid parallel to the 230 V cable. This means that:

- ✚ the amount of cabling compared to conventional installation technology is considerably reduced when bus devices are arranged in a decentralized way
- ✚ the number of possible system functions is increased
- ✚ the transparency of the installation is improved.

This cable:

- ✚ connects loads and switches
- ✚ supplies the bus devices with energy in most cases.

A central control unit (e.g. PC) is not necessary as all the bus devices have their own intelligence. KNX can therefore be used both in small installations (flats) and large projects (hotels, administration buildings...).

## 4 KNX System specification

### 4.1 KNX Media

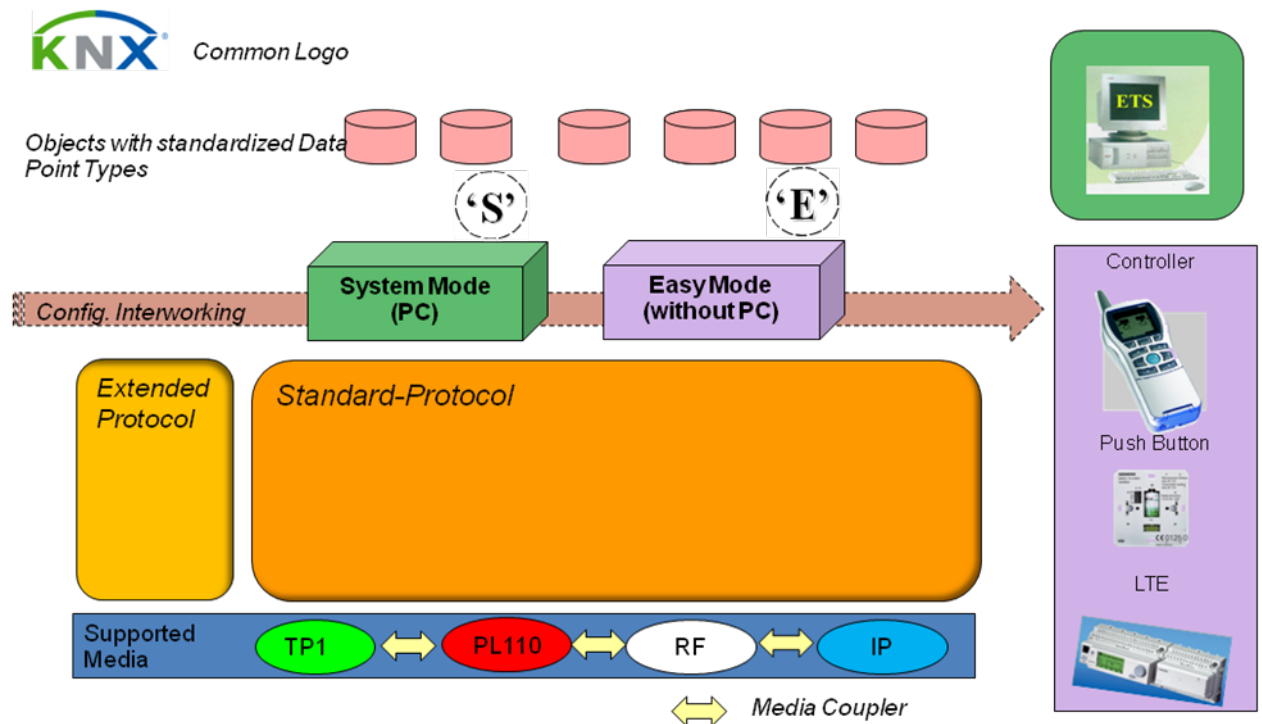

**Figure 3: KNX Media**

Due to the flexibility of the KNX technology, a KNX installation can easily be adapted to the changing circumstances of the user.

It is also possible to implement KNX on the existing 230 V cable (“Powerline transmission medium”), on radio (“KNX Radio Frequency transmission medium”) and on Ethernet (“KNX IP”). Via appropriate gateways, transmission of KNX telegrams is also possible on other media, e.g. optical fibre.

One Twisted Pair solution exists (Twisted 1), one Power Line medium exists (Powerline 110), one RF and one IP solution. When connecting different media, appropriate media couplers have to be used. The used medium of a device is visible on the product’s label.

## 4.2 Areas of application for the various media

Medium	Transmission via	Preferred areas of application
Twisted Pair	Separate control cable	New installations and extensive renovations– highest level of transmission reliability
Powerline	Existing network <sup>[1]</sup>	In places where an additional control cable does not need to be laid and a 230 V cable is available
Radio Frequency	Radio line	In places where cables cannot be laid or are not wanted
IP	Ethernet	In large installations where a fast backbone is needed.

<sup>[1]</sup> Neutral conductor must be available in the case of PL110

Figure 4: Areas of Application for the various media

### 4.2.1 Types of Configuration

Depending on what is marked on the label of the device, devices can be configured (i.e. linked and parameters set) via:

- ✚ Easy installation techniques (*E-MODE*): configuration is done without the help of a PC but with a central controller, push buttons...  
This type of configuration is intended for the skilled contractor with basic bus knowledge. Easy compatible products normally have limited functionality and are intended for medium size installations.
- ✚ Last but not least, system installation techniques (*S-MODE*): planning of the installation and configuration is done via a PC with the installed manufacturer-independent ETS Software, whereby the manufacturers' product data is contained in the ETS database.  
This type of configuration is intended for KNX certified planners and contractors and for large size installations.

Some devices allow configuration via easy installation techniques as well as system mode<sup>1</sup>. For instance, products with the LTE label are normally configured via the LTE mechanisms: all devices however include a defined S-mode interface, which allows linking of them with S-mode compliant devices.

<sup>1</sup> In the case where the product is also labelled with the EIB logo only next to the KNX logo, this implies that the product uses the medium TP1 and can be configured by ETS.

## 5 KNX Interworking

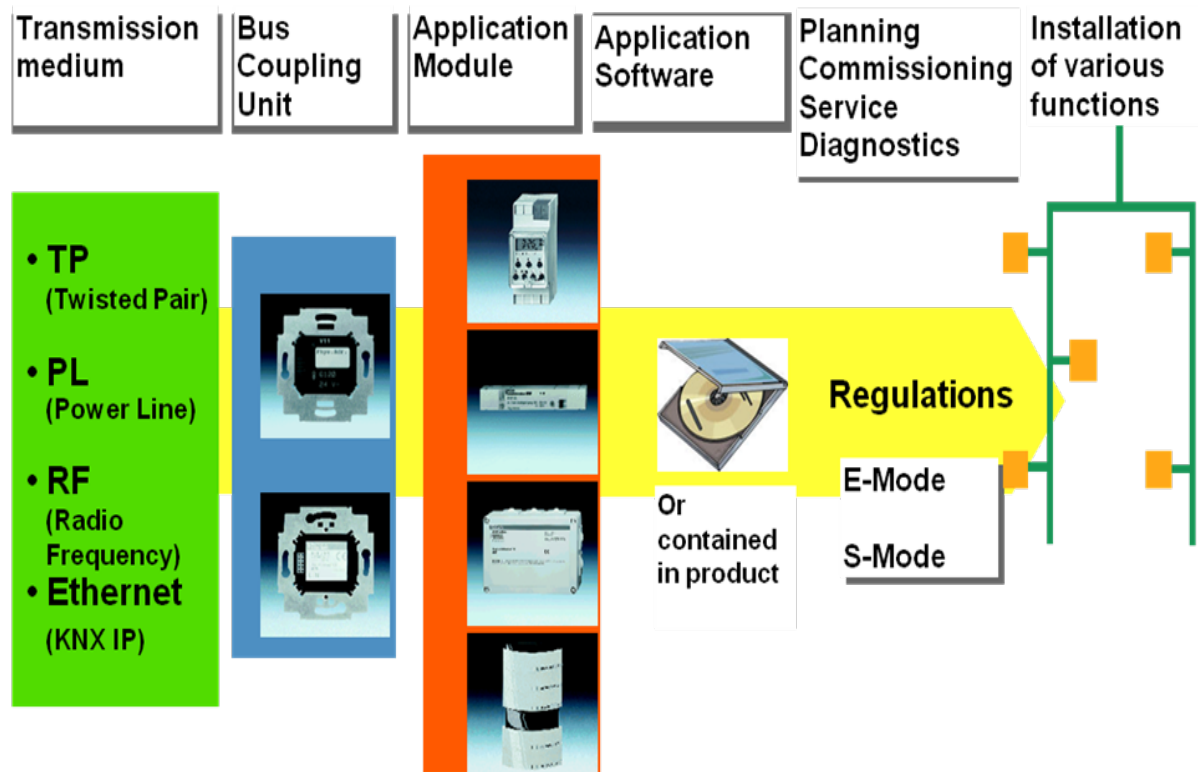

**Figure 5: KNX Interworking**

Devices from different manufacturers and functional areas that are labelled with the KNX trademark and using the same configuration mechanism can be linked to form a functioning installation thanks to the KNX standardization of

- ✚ Telegrams: devices usually transmit the standard telegrams, but there are also devices that support the new telegram format;
- ✚ Useful data in telegrams: for various functions (a.o. switching, dimming, shutter control, HVAC...), the use of predetermined formats is an obligation for certification.

It is foreseen that ETS in future versions will also allow the linking of non S-mode configured products.



## 6 Success Rate<sup>2</sup>

- ✚ Millions of installed products
- ✚ thousands of KNX registered and certified products (including legacy solutions)
- ✚ more than 300 KNX members
- ✚ more than 230 recognized training centres
- ✚ 7 European test sites
- ✚ tens of thousands of implemented projects

## 7 The Advantages of KNX

- ✚ Increased safety
- ✚ Economic use of energy during the operation of buildings
- ✚ Simple adaptation of the electrical installation to the changing requirements of the user
- ✚ Higher degree of convenience
- ✚ future-proof installations
- ✚ wide range of available off-the-shelf components from many manufacturers
- ✚ large service network of qualified contractors/planners/integrators

The above arguments are evaluated differently from the point of view of the client or the user of the installation e.g. functional building compared to residential building, able-bodied people compared to disabled people, young people compared to elderly people,....

*Example 1:* Implementation of central functions – when you are leaving the building, all the lights, the water supply and specific sockets (electric oven...) can be switched off, the KNX alarm system can be activated and the blinds can be controlled dependent on the time of day.

*Example 2:* In conference rooms, theatres as well as living rooms, it is possible to activate different light scenes depending on the activity which can be modified by the user at any time. For example in administration buildings, it is possible to achieve an energy saving of up to 75% for the lighting system by implementing constant light control with only one brightness sensor for each side of the building.

*Example 3:* All the states in a flat can be indicated and operated in clear text via display units (fixed but also mobile devices such as smartphones or tablet computers). This can be implemented in the same way in larger installations using PCs and visualisation software.

---

<sup>3</sup> For current figures, please consult the KNX web site ([www.knx.org](http://www.knx.org))

*Example 4:* By interfacing a KNX installation with the telephone network, the user can influence or query the building management functions (e.g. the heating) using a mobile phone. Alarm signals can be automatically routed to any telephone number as required. KNX installations can also be remotely serviced and configured by the installer using any available media (e.g. the Internet). The time required for maintaining the building management system is thus considerably reduced.

*Example 5:* It should be possible to divide a large conference room into several independent areas if the need arises. By inserting partition walls, the KNX installation automatically detects the required assignment of switches and lights per room section. It is therefore not necessary to change the existing cabling.

*Example 6:* Any number of panic switches (e.g. activation of all the lights) can be installed.

At night, the lights between the children's bedroom and the bathroom can be activated by pressing a button and deactivated after a set period.

*Example 7:* KNX enables individual room control of the heating and cooling system with the creation of heating and cooling profiles per room. The heat or cold input for a room is automatically adjusted when a window is opened. These measures make it possible to achieve an energy saving of more than 30% per year.

The heat generation can also be controlled dependent on the heat requirement of the individual rooms (heat is only produced when it is actually required).

*Example 8:* KNX enables presence simulation when the user is absent.

*Example 9:* The energy consumption of individual electric circuits can be monitored by energy sensors /energy actuators and can be switched off when exceeding predefined threshold values in order to improve load management. Combined with a gateway to Smart Metering devices or renewable energy sources, it is therefore possible to ensure the optimal use of self-generated energy (e.g. in combination with a future electric vehicle).

## 8 Selling the benefits

### KNX: Arguments towards customers

#### Definitely...

- **Beneficial to**
- **Geared to**

#### Not...

- **Cost-oriented**
- **Technically oriented**



#### Emergency solutions...

- **Replanning of functions**
- **Use of cost-effective KNX product solutions**

Figure 6: Selling the benefits

During a consultation with a future customer, the electrical contractor or planner should discuss KNX only in terms of its benefits to the customer and that it is geared to the requirements of the customer. Technology and costs should not be at the forefront for the time being. The result of this discussion should be a quotation for the system and not for components. The process should continue as follows:

- ✚ Discuss the system quotation with the customer and again stress the benefits for the customer;
- ✚ If the price for the system cannot be accepted, functions should be re-planned (e.g. switching instead of dimming);
- ✚ In extreme cases, the price of the installation can be reduced using the following components:
  - push button interfaces with conventional push buttons
  - push button BCU
  - multiple switch actuators

# KNX Communication

KNX Association

## Table of Contents

1	Basic Method of Operation.....	3
2	Individual address .....	<b>Error! Bookmark not defined.</b>
3	Group Address.....	6
4	Group object .....	<b>Error! Bookmark not defined.</b>
4.1	Flags .....	9
5	Useful Data of a TP1 telegram.....	10
6	Standardized Datapoint Types (DPT).....	11
6.1	Switch (1.001) .....	12
6.2	Functional block Shutter Control.....	13
6.3	Switch Control (2.001) .....	14
6.4	Functional Block “Dimming”.....	15
6.5	2 Octet Float Value (9.00x).....	17
7	TP1 Bit Structure.....	18
8	TP1 Telegram Collision.....	19
9	TP1 Symmetrical Transmission.....	20
10	Superimposing Data and Supply Voltage .....	21
11	Connection of the Power Supply Unit to the TP1 Bus .....	22
12	TP1 Cable Lengths .....	23
12.1	Cable Length between TP1 Power Supply Unit and TP1 Bus Device.....	24
12.2	Cable Lengths between two TP 1 Bus Devices .....	25
12.3	Total Cable Length per TP 1 Line Segment .....	25

## Definition

The following terms are used as synonyms in KNX literature:

- ✚ Physical address and individual address
- ✚ Communication object and group object

The terms **individual address** and **group objects** are commonly used in the KNX training documentation as well as in ETS.

## 1 Basic Method of Operation

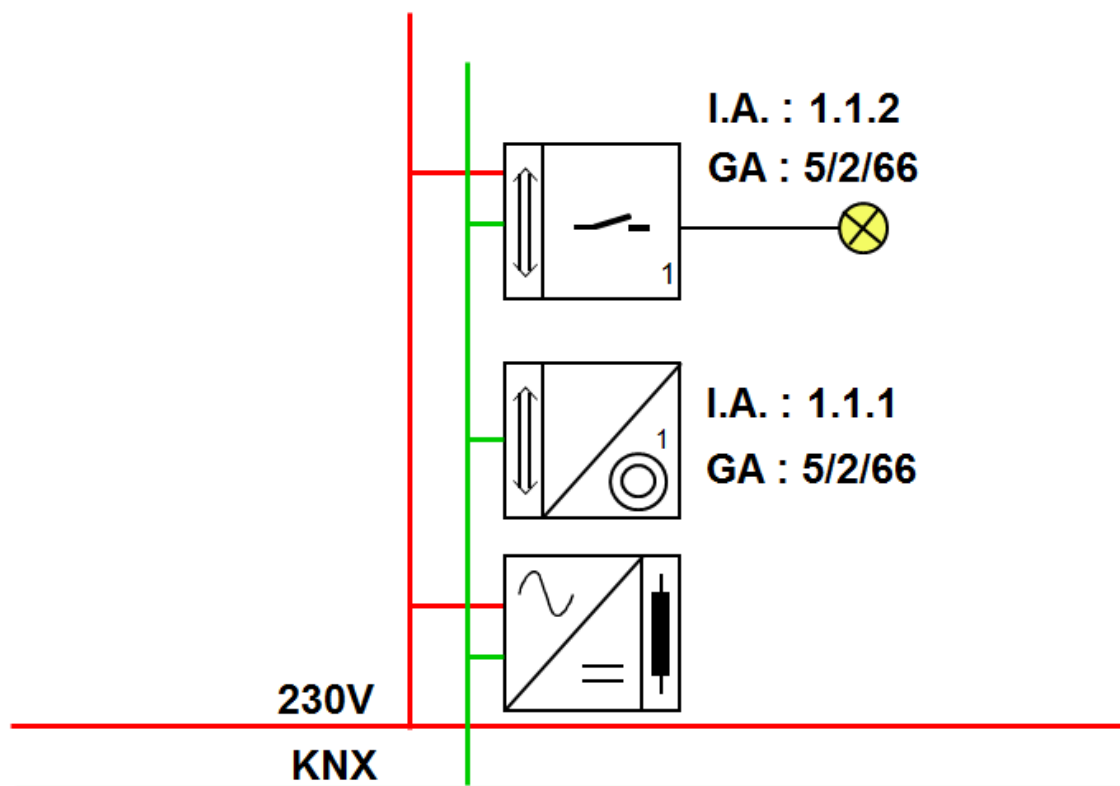

**Figure 1: Basic method of operation**

A minimum TP1 KNX installation consists of the following components:

- ✚ a power supply unit (DC 30 V)
- ✚ a choke (can also be integrated in the power supply unit)
- ✚ sensors (a single switch sensor is represented in the figure above)
- ✚ actuators (a single switch actuator is represented in the figure above)
- ✚ bus cable (only two wires of the bus cable are required).

After the installation and in the case of S-mode compatible products, a KNX system is not ready for operation until sensors and actuators have been loaded with application

software with the help of the ETS™ program. The project engineer must first have carried out the following configuration steps using ETS:

- ✚ assignment of individual addresses to the different devices (for the unique identification of a sensor or actuator in a KNX installation);
- ✚ selection and setting (parameterisation) of the appropriate application software for sensors and actuators;
- ✚ assignment of group addresses (for linking the functions of sensors and actuators).

In the case of E-mode compatible products, the same steps as above have to be applied, whereby:

- ✚ the individual addresses
- ✚ parameterisation of the appropriate application software for sensors and actuators and;
- ✚ the assignment of group addresses (for linking the functions of sensors and actuators)

is done via either local settings or automatically by a central controller.

After the above configuration, the installation could function as follows:

- ✚ If the upper rocker of the single switch sensor (1.1.1) is pressed, it sends a telegram which contains the group address (5/2/66) and the value ("1") as well as miscellaneous data.
- ✚ This telegram is received and evaluated by all connected sensors and actuators.
- ✚ Only the devices with the same group address:
  - send an acknowledgement telegram
  - read the value and behave accordingly. In our example, the switch actuator (1.1.2) will close its output relay.

When the lower rocker is pressed, the same process occurs except that the value is set to "0" this time and the output relay of the actuator is thereby opened.

The respective elements of the KNX system are explained in more detail on the following pages.

## 2 Individual address

**A = Area**

**L = Line**

**B = Bus device**

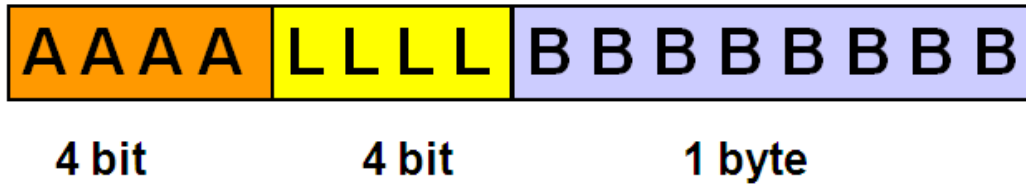

**Figure 2: Individual address**

An individual address must be unique within a KNX installation. The individual address is configured as described above. It has the following format: Area [4 bit] - Line [4 bit] – Bus device [1 byte]. The bus device is normally prepared for the acceptance of its individual address by pressing a programming button on the bus device. The programming LED is lit during this process. The individual address is also used for the following purposes after the commissioning stage:

- ✚ Diagnosis, error rectification, modification of the installation by reprogramming
- ✚ Addressing of the interface objects using commissioning tools or other devices.

**Important: The individual address has no significance during normal operation of the installation.**



### 3 Group Address

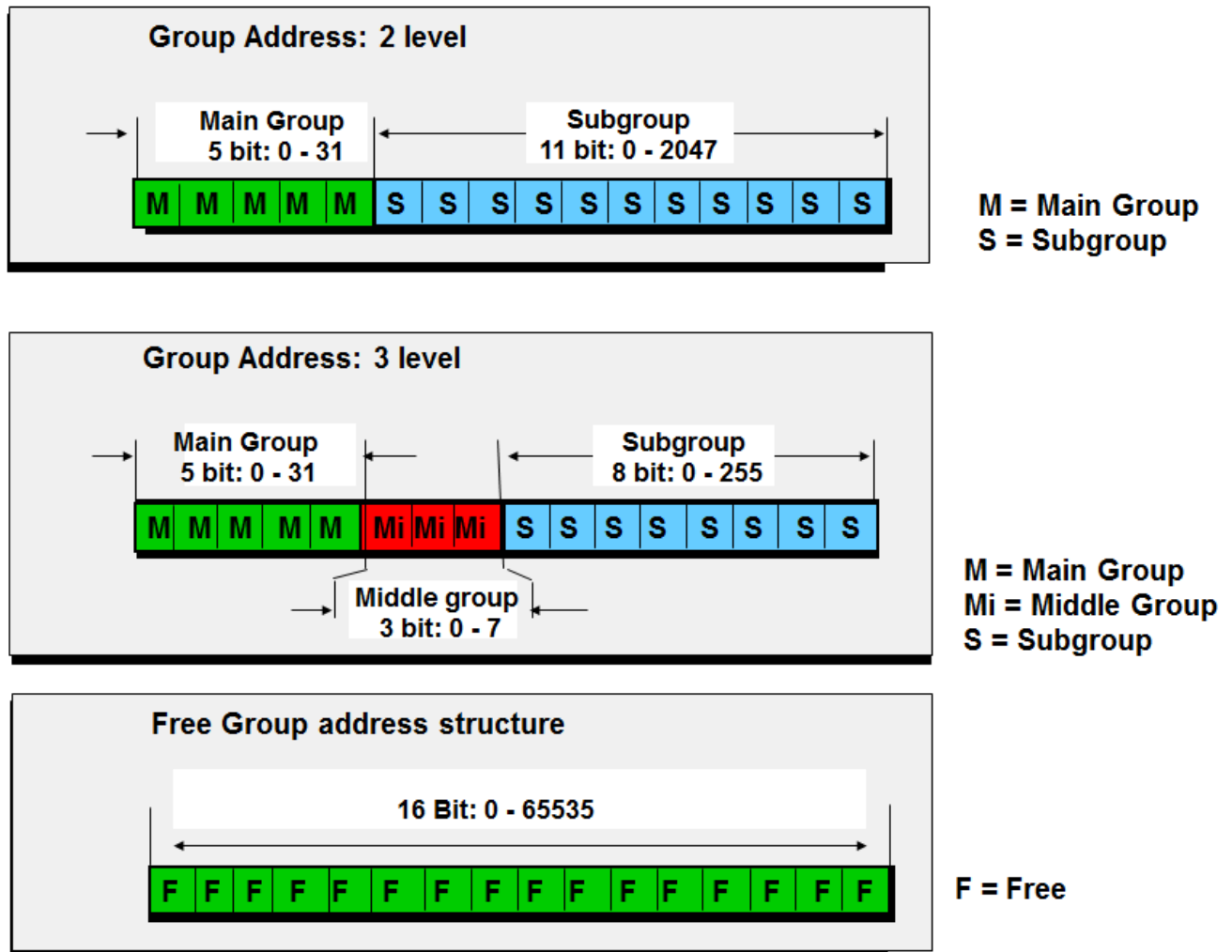

**Figure 3: Group Address**

Communication between devices in an installation is carried out via group addresses. When setting the group address via ETS, it can be selected as a “2-level” (main group/subgroup), “3-level” structure (main group/middle group/subgroup) or a freely defined structure. The level structure can be changed in the project properties of each individual project.. The group address 0/0/0 is reserved for so-called broadcast messages (telegrams to all available bus devices).

The ETS project engineer can decide how the levels will be used e.g. as in the following pattern:

- ✚ Main group = floor
- ✚ Middle group = functional domain (e.g. switching, dimming)
- ✚ Subgroup = function of load or group of loads (e.g. kitchen light on/off, bedroom window on/off, ceiling living room on/off, ceiling living room dimming,...).

One should stick to the selected pattern of group addresses in all projects.

Each group address can be assigned to the bus devices as required, regardless of where the device is installed in the system.

Actuators can listen to several group addresses. Sensors however can only send one group address per telegram.

The group addresses are assigned to the group objects of the respective sensors and actuators, either by creating and assigning them with the help of ETS (S-mode) or automatically and invisible to the user in E-mode.

**Note:**

- ✚ When using the main groups 14 resp. 15 or higher in ETS, you should take into account that these group addresses are not filtered by TP1 couplers and could therefore negatively influence the dynamics of the entire bus system.
- ✚ The number of group addresses that can be attributed to a sensor or actuator is variable and depends on the size of the memory.

## 4 Group object

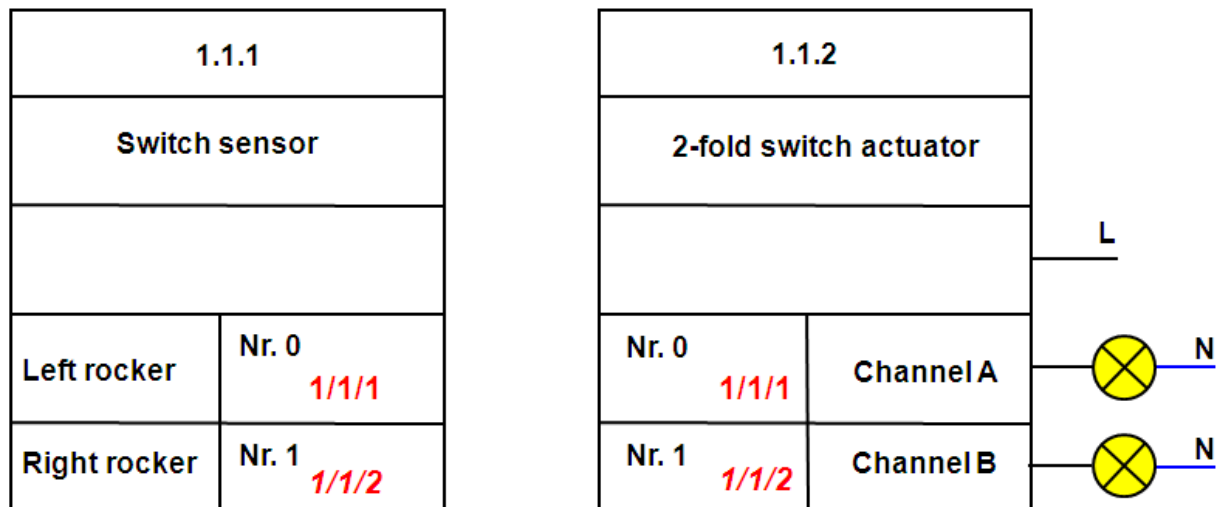

**Series connection: KNX technology**

**Figure 4: Group object**

KNX group objects are memory locations in bus devices. The size of these objects can be between 1 bit and 14 bytes. The size of the group objects is dependent on its function.

As only two states (0 and 1) are required for switching, 1 bit group objects are used. The data involved in text transmission is more comprehensive and therefore group objects with a maximum size of 14 bytes are used.

The ETS only allows to link objects with the same size using group addresses. Several group addresses can be assigned to one group object, but only one is the sending group address.

An object value is sent on the bus in the following way:

- a) If the upper left rocker is pressed for example, the two-fold switch sensor writes a “1” to its group object with the number 0. As the communication and transmit flag are set for this object, this device will send a telegram on the bus with the information “Group address 1/1/1, write value, 1”.
- b) All the bus devices throughout the KNX installation that also have the group address 1/1/1 will then write “1” in their own group object.
- c) In our example, the “1” is written in group object no. 0 of the actuator.
- d) The application software of the actuator establishes that the value in this group object has changed and executes the switching process.

## 4.1 Flags

Each group object has flags which are used to set the following properties:

<b>Communication</b>	<input checked="" type="checkbox"/>	The group object has a normal link to the bus.
	<input type="checkbox"/>	Telegrams are acknowledged. The group object is not modified.
<b>READ</b>	<input checked="" type="checkbox"/>	The object value can be read via the bus.
	<input type="checkbox"/>	The object value CANNOT be read via the bus.
<b>WRITE</b>	<input checked="" type="checkbox"/>	The object value can be modified via the bus.
	<input type="checkbox"/>	The object value CANNOT be modified via the bus.
<b>TRANSMIT</b>	<input checked="" type="checkbox"/>	A telegram is transmitted when the object value (at the sensor) has been modified.
	<input type="checkbox"/>	The group object will generate a response only when receiving a read request.
<b>UPDATE</b>	<input checked="" type="checkbox"/>	Value response telegrams are interpreted as a write command. The value of the group object is updated (always enabled in System 1 devices)
	<input type="checkbox"/>	Value response telegrams are NOT interpreted as a write command. The value of the group object remains unchanged.
<b>READ ON INIT</b>	<input checked="" type="checkbox"/>	The device independently sends Read value commands for the initialisation of the group object after return of current (only available on certain masks)
	<input type="checkbox"/>	After return of current the device <i>does not</i> initialise the value of the assigned group object via Read Value commands

**Please note:** The default flags should only be changed in exceptional circumstances.

For further information you can consult the topic “Flags” in the chapter “Project Design” of the basic course documentation or the chapter “Flags” in the advanced course documentation.

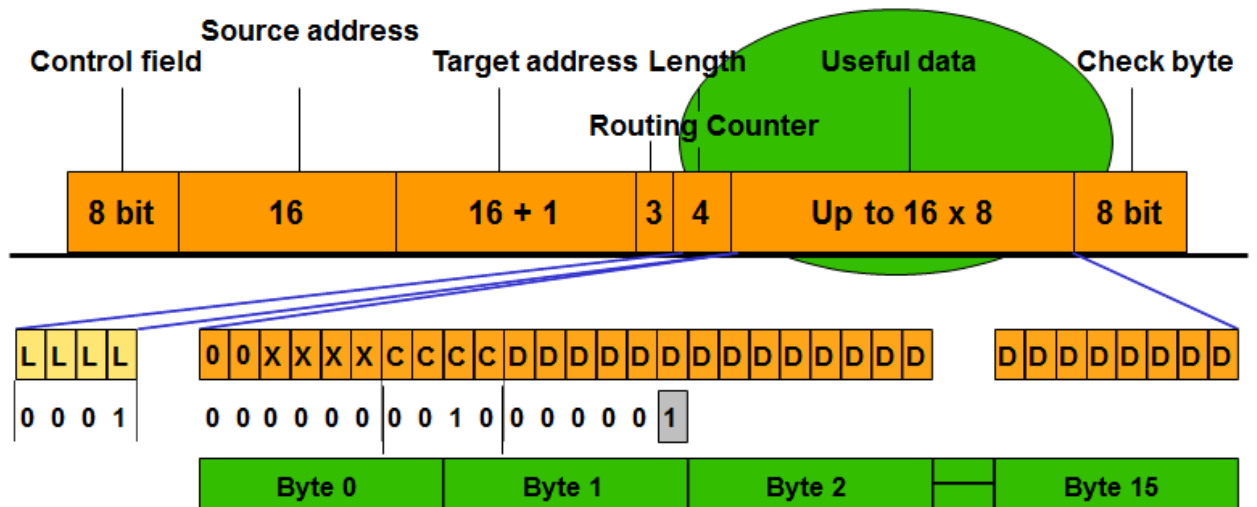

The actual payload is explained here using the example of a 1-bit telegram.

**Legend**

- C = Command
- D = Data (dependent on the data point type[DPT])
- L = Length of the useful data (dependent on DPT)
- X = No evaluation

**Selected commands**

- 0000 Value Read
- 0001 Value Response
- 0010 Value Write
- 1010 Memory Write

Figure 5: Useful data of TP1 telegram

## 5 Useful Data of a TP1 telegram

The actual payload determines the type of command. The actual payload is explained in the above figure using the example of a 1-bit telegram. In the case of the “write” command the last bit on the right contains a “1” or a “0” for “Switch on” or “Switch off”.

A “read” command requests the addressed group object to report its status. The reply may be a 1-bit message as in the example of the “write” command, or it can use up to 13 bytes (bytes 2 to 15).

The length of the data is dependent on the datapoint type used.

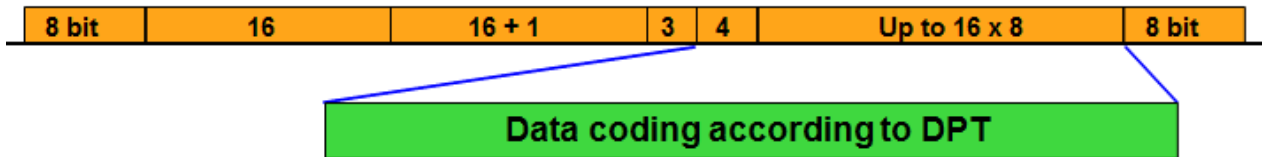

Figure 6: Standardized Datapoint types

## 6 Standardized Datapoint Types (DPT)

Datapoint types were standardised to guarantee the compatibility of similar devices from different manufacturers (e.g. dimmers, clock).

The standardisation includes requirements on the data format and structure of the group objects as well as for sensor and actuator functions. The combination of several standardised datapoint types (e.g. in dimming actuators) is called a functional block.

The designation of a datapoint type is geared towards the application for which it was conceived. This does not always imply that the use of the DPT is limited to this area of application. For example “Scaling” (Type 5.001) can also be used both for setting a dimming brightness or for setting a heating valve position.

A selection of frequently used datapoint types is given on the following pages. The full list of standardised datapoint types can be downloaded from the KNX web site ([www.knx.org](http://www.knx.org)).

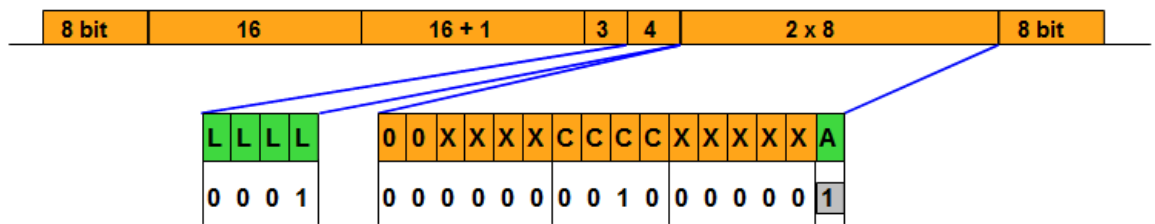

**Group object:**  
Switch = 1 Bit

**Values:**  
1 = On / Enable / true / Alarm  
0 = Off / disable / false / no Alarm

**Legend:**  
A = Switching object  
C = Command (0010 = write telegram)  
L = Length of useful data (byte 0 to byte 1)  
X = No evaluation

**Example of a telegram:**  
Actuator channel switches on

Figure 7: DPT Switch (1.001)

### 6.1 Switch (1.001)<sup>1</sup>

The switch function is used for switching an actuator function. Other one bit datapoint types are defined for logical operations (Boolean [1.002]), Enable [1.003]), etc...).

Other functions or extensions to the pure switching function (inversion, time delay and toggle switch functions) are not part of the DPT description but parameters of the functional block specification, in which this DPT is used (e.g. functional block light switch).

<sup>1</sup> previously referred to as EIS1

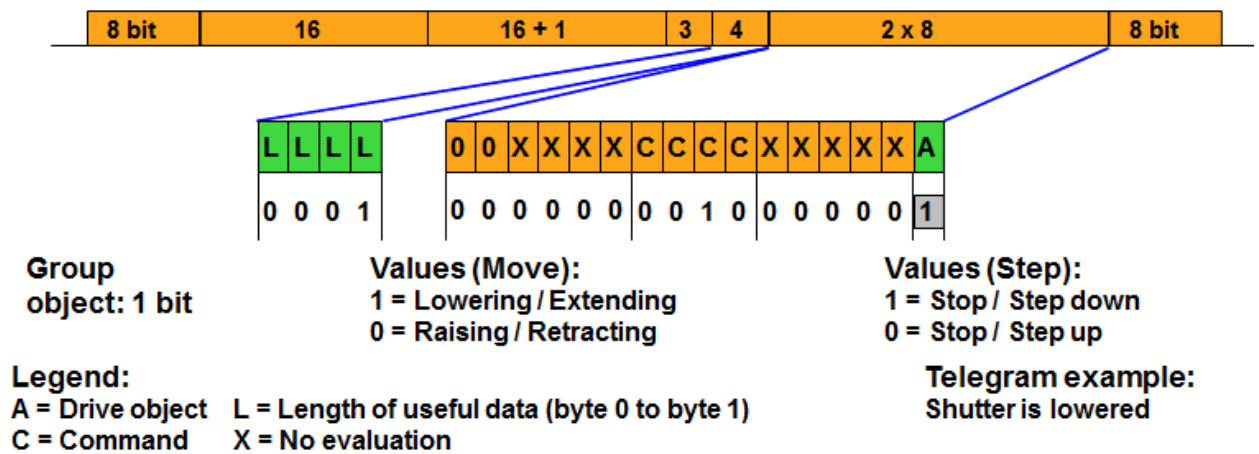

Figure 8: Functional block Shutter Control

## 6.2 Functional block Shutter Control<sup>2</sup>

The functional block “Shutter control” is principally used for the control of shutter and blind drive mechanisms and provides at least the following datapoint types as group objects

- ⚡ Up/Down (1.008)
- ⚡ Step (1.007).

By writing on the Up/Down, a drive is set in motion from an idle state or changes direction while moving.

By writing on the Step, a drive which is already in motion is brought to a stop or a halted drive is set in motion for short periods (step-by-step).

**Important:** Group objects which use this function should never reply to read requests via the bus as they may unintentionally stop moving drives or set halted drives in motion. The “read” flag should therefore be deactivated in the relevant group objects – both in sensors as well as actuators. This especially applies for central functions.

<sup>2</sup> previously referred to as EIS7



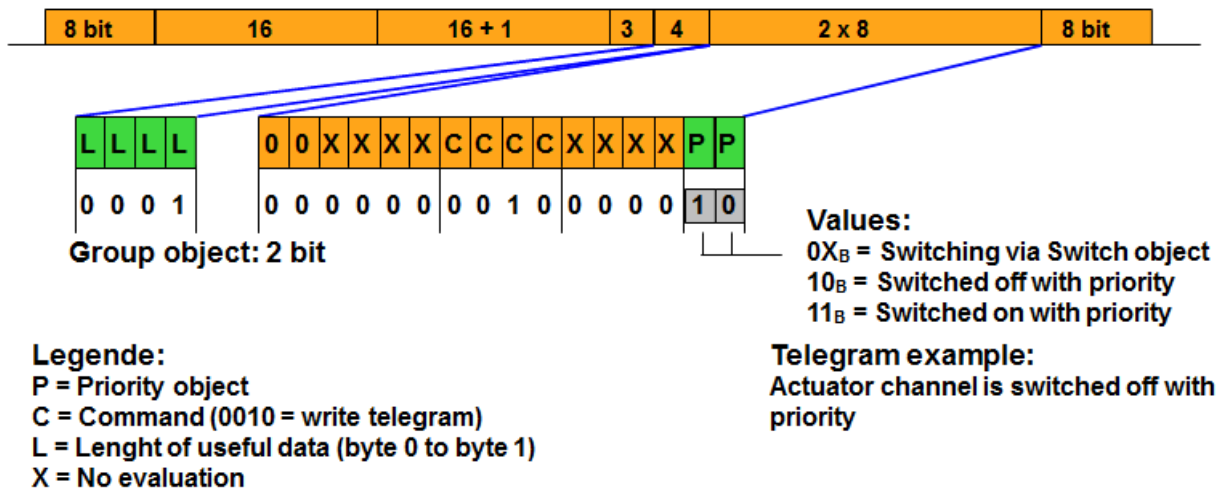

Figure 9: Switch Control (2.001)

### 6.3 Switch Control (2.001)<sup>3</sup>

The Switch Control is used to operate actuators – next to the normal operation via the Switch – by a group object with higher priority.

The switching function of a connected device depends on the state of the two group objects Switch and Switch Control.

The group object of type Switch Control has a size of 2 bits.

If the value of the 2 bit object is 0 or 1, the connected actuator is controlled via the switching object.

If the value of the priority object is 2, the output is switched off respectively on when the value is 3. The value of the switching object is in both cases ignored.

<sup>3</sup> Previously referred to as EIS 8

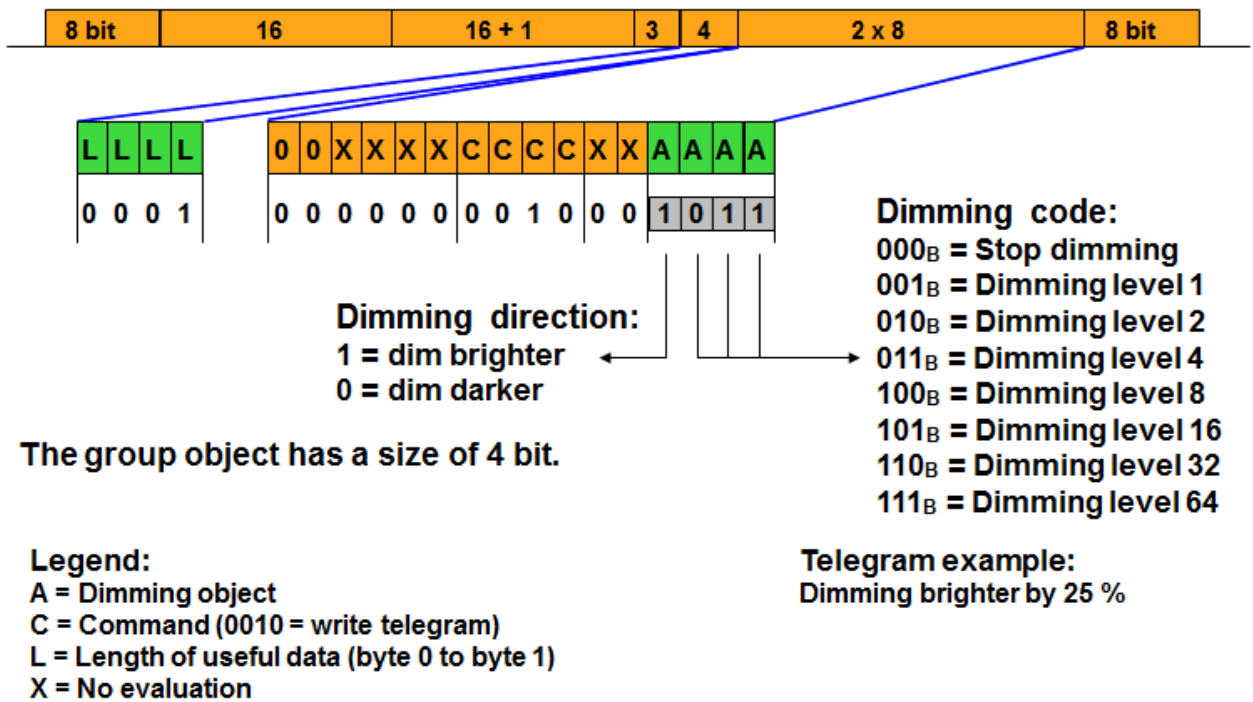

Figure 10: Functional Block "Dimming"

### 6.4 Functional Block "Dimming"<sup>4</sup>

Apart from the 4 bit object (Dim Step – 3.007), the functional block dimming consists of at least a switching object (corresponds to Switch) and a value object (corresponds to Scaling – 5.001).

A dimming command, relative to the current brightness setting, is transmitted to the dimming actuator using the Dim Step.

Bit 3 of the useful data determines whether the addressed device dims down or up compared to the current brightness value.

Bits 0 to 2 determine the dimming range. The area of brightness (0-100%) is divided into 64 dimming levels. The dimming actuator always dims to the next dimming level. For example: a dimming actuator has a brightness level of 30%. If a sensor sends 1011<sub>B</sub> as useful data, a dimming brighter command is carried out until the next dimming threshold is reached (or 100% divided by 4 = 25%, i.e. the next level is 50%).

The dimming code 0 (i.e. useful data 00<sub>HEX</sub> or 80<sub>HEX</sub>) means "Stop Dimming". The dimming process is interrupted and the current brightness value is retained.

<sup>4</sup> previously referred to as EIS 2

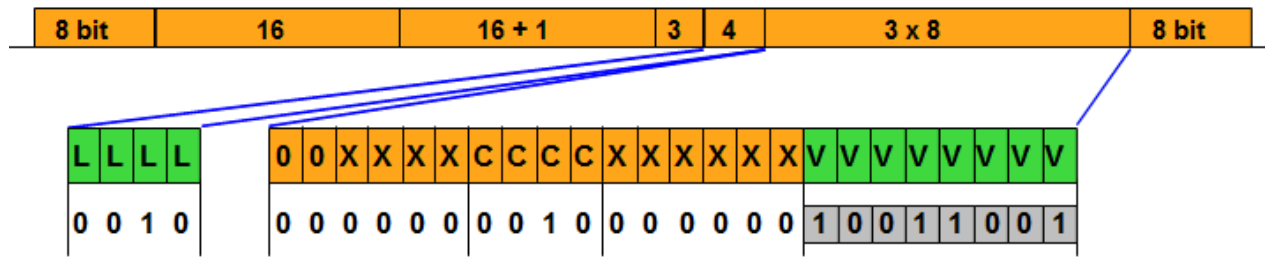

**Legend:**  
 V = Value  
 B = Command (0010 = Write telegram)  
 L = Length of useful data (byte 0 to byte 2)  
 X = No evaluation

**Telegram example:**  
 Brightness value 60 % (153)

Figure 11: Value object

With the Scaling, a brightness value between 1 (minimum) and 255 (maximum) is set directly.

Depending on the manufacturer’s application, it may be possible to switch on ( $1 \leq \text{value} \leq 255$ ) or off (value = 0) a connected device using this DPT.

The DPT has a size of 1 byte.



„0“ and „1“ are the two logical states a bit can possess.

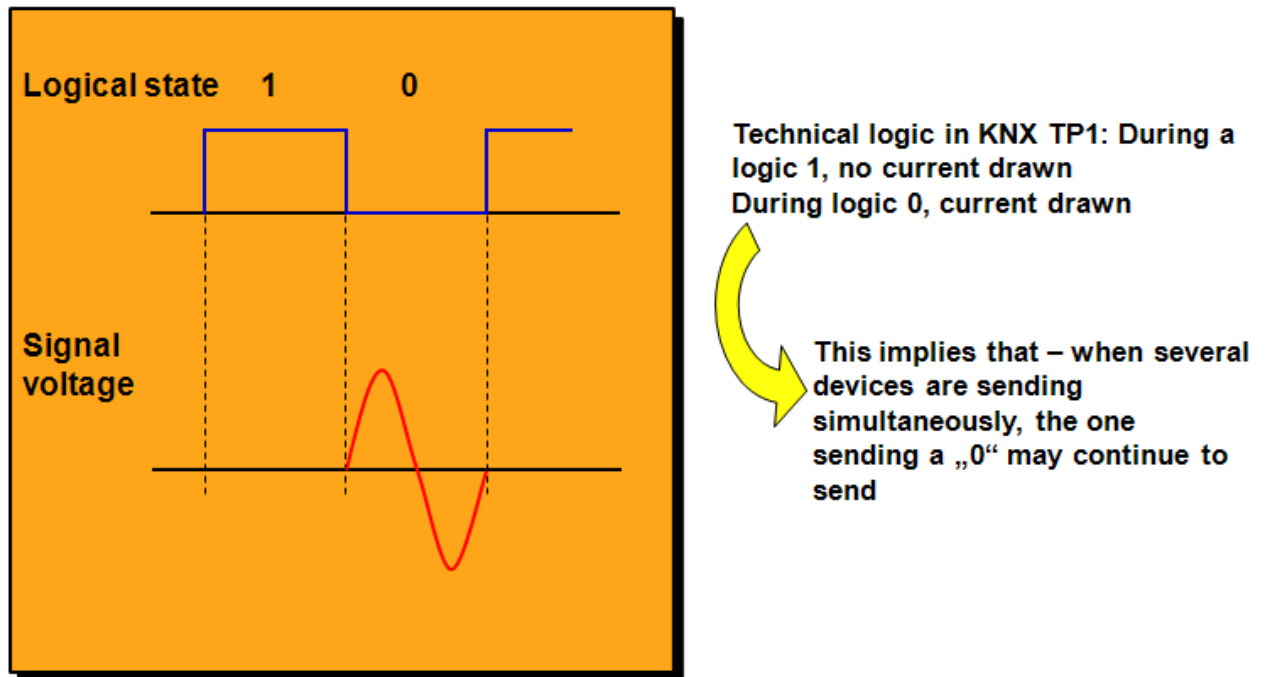

Figure 13: TP1 bit structure

## 7 TP1 Bit Structure

“0” and “1” are the two logical states a bit can possess.

Technical logic in KNX TP1:

- ✚ During logical state “1”, no signal voltage is available
- ✚ During logical state “0”, signal voltage is available

If several bus devices transmit simultaneously, the logical state “0” prevails!

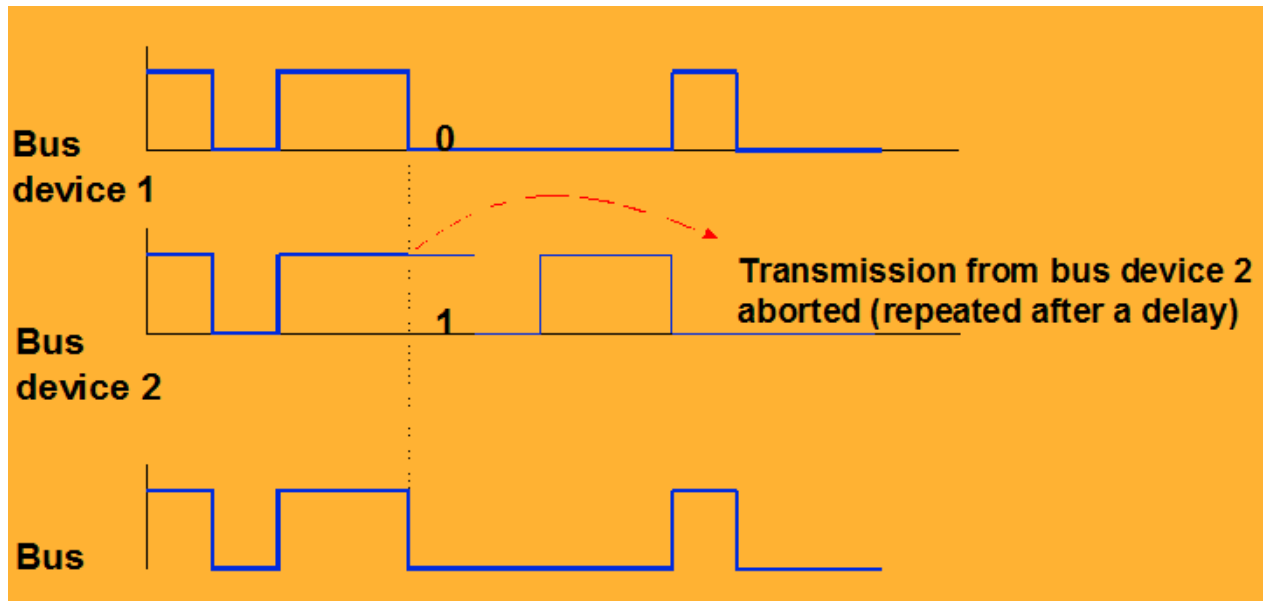

Figure 14: TP1 Telegram Collision

## 8 TP1 Telegram Collision

A bus device with data to transmit may start transmission immediately if it finds the bus unoccupied.

The simultaneous sending request of several bus devices is controlled by the CSMA/CA procedure (Carrier Sense Multiple Access with Collision Avoidance).

The bus devices listen to the bus while transmitting. As soon as a bus device with the logical state "1" detects the logical state "0" (= flow of current on the line), it stops transmitting to give way to the other sending device.

The bus device that terminated its transmission continues to listen to the network to await the end of the telegram transmission and then retries its transmission.

In this way, if several bus devices are attempting to transmit simultaneously, the CSMA/CA procedure ensures that only one of these bus devices can terminate its transmission uninterrupted. The data throughput is therefore not reduced.

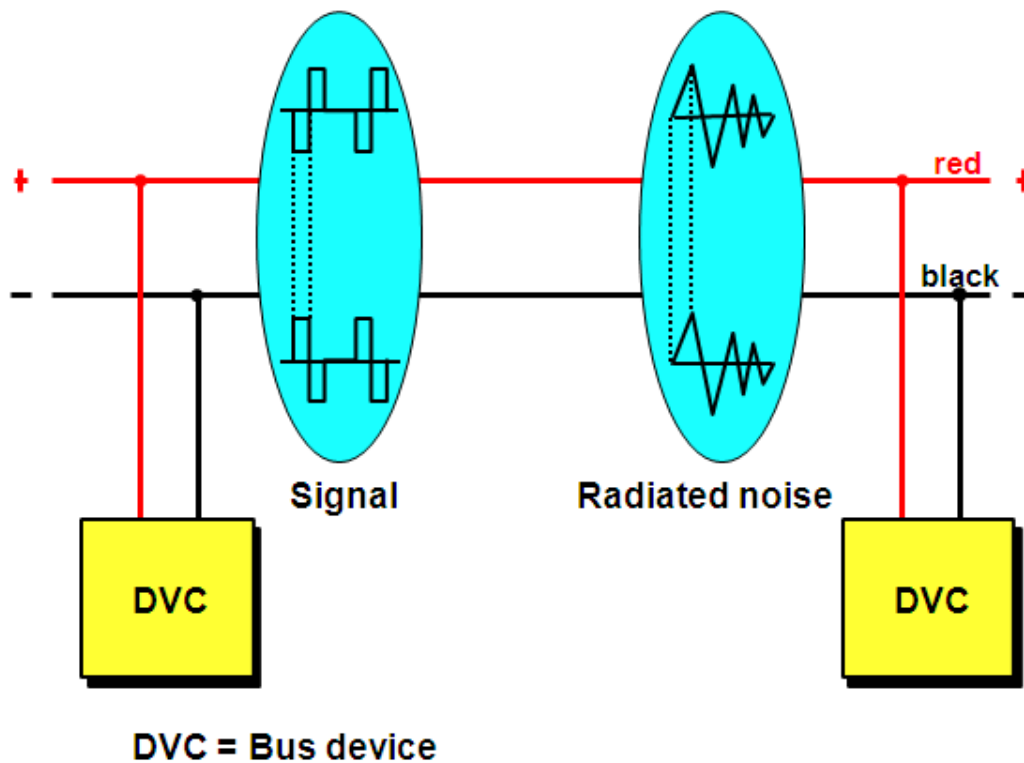

Figure 15: TP1 Symmetrical Transmission

## 9 TP1 Symmetrical Transmission

The data is transmitted symmetrically over the pair of cores. Bus devices evaluate the difference in voltage between the two cores.

As radiated noise affects both cores with the same polarity, it has no influence on the difference in the signal voltage.

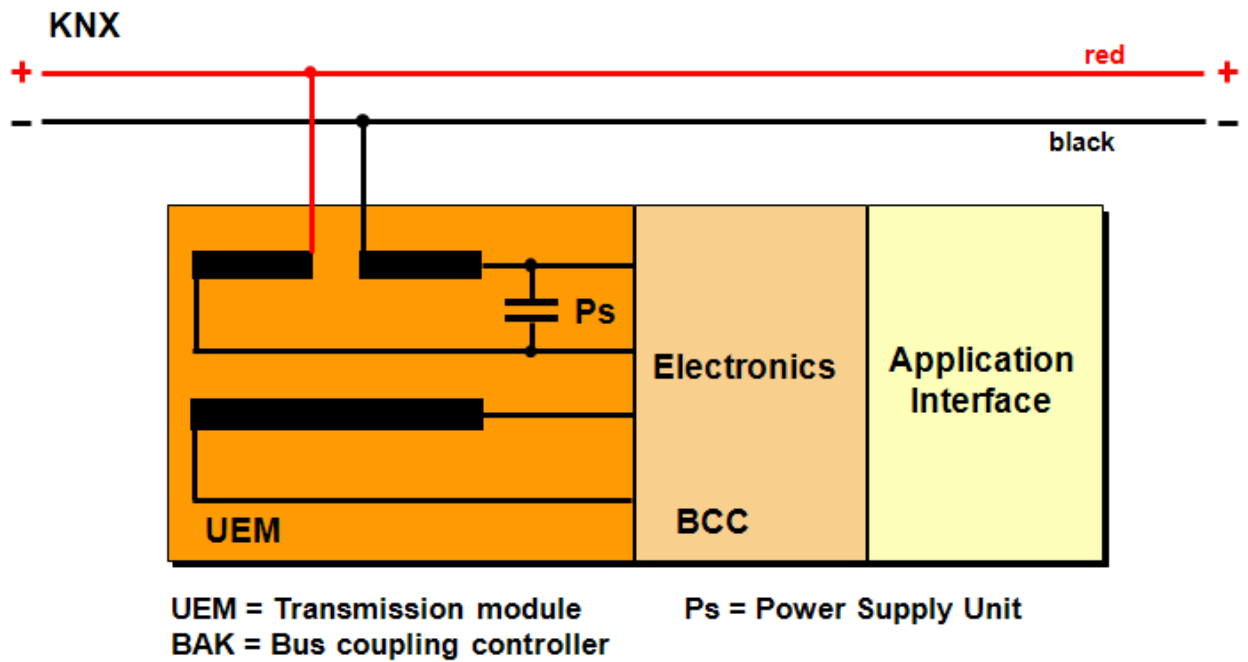

Figure 16: Superimposing Data and Supply Voltage

## 10 Superimposing Data and Supply Voltage

Data is transmitted in the form of a.c. voltage. The capacitor reacts with a low resistance to a.c. voltage, i.e. it acts as a conductor and closes the circuit on the primary side. When acting as a transmitter, the transformer sends the data to the primary side (in the form of a.c. voltage) where it is superimposed onto the d.c. voltage.

When acting as a receiver, the transformer sends the data to the secondary side where it is separately available from the d.c. voltage.



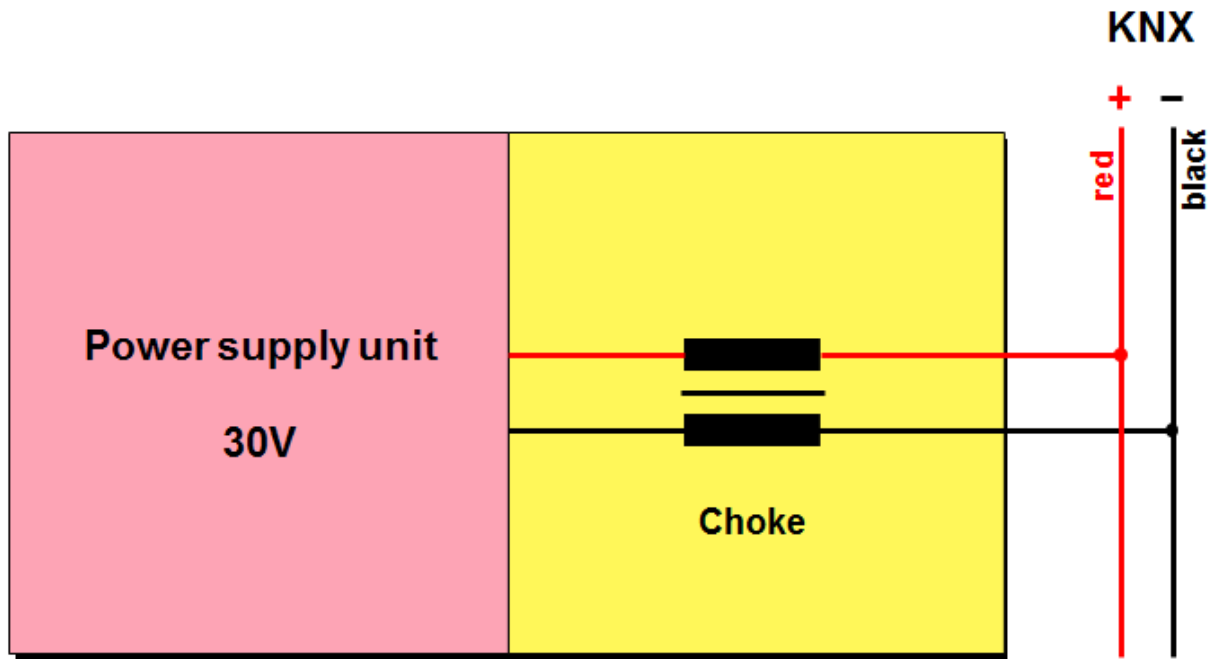

Figure 17: Connection of Power supply to TP1 bus

## 11 Connection of the Power Supply Unit to the TP1 Bus

The power is supplied to the installation bus via a choke.

When d.c. voltage is supplied, the choke reacts with low resistance (as the frequency is equal to 0 Hz). The data is transmitted in the form of a.c. voltage (frequency is not equal to 0). The choke reacts with high resistance to a.c. voltage.

Hence the power supply unit's influence on the data is negligible.

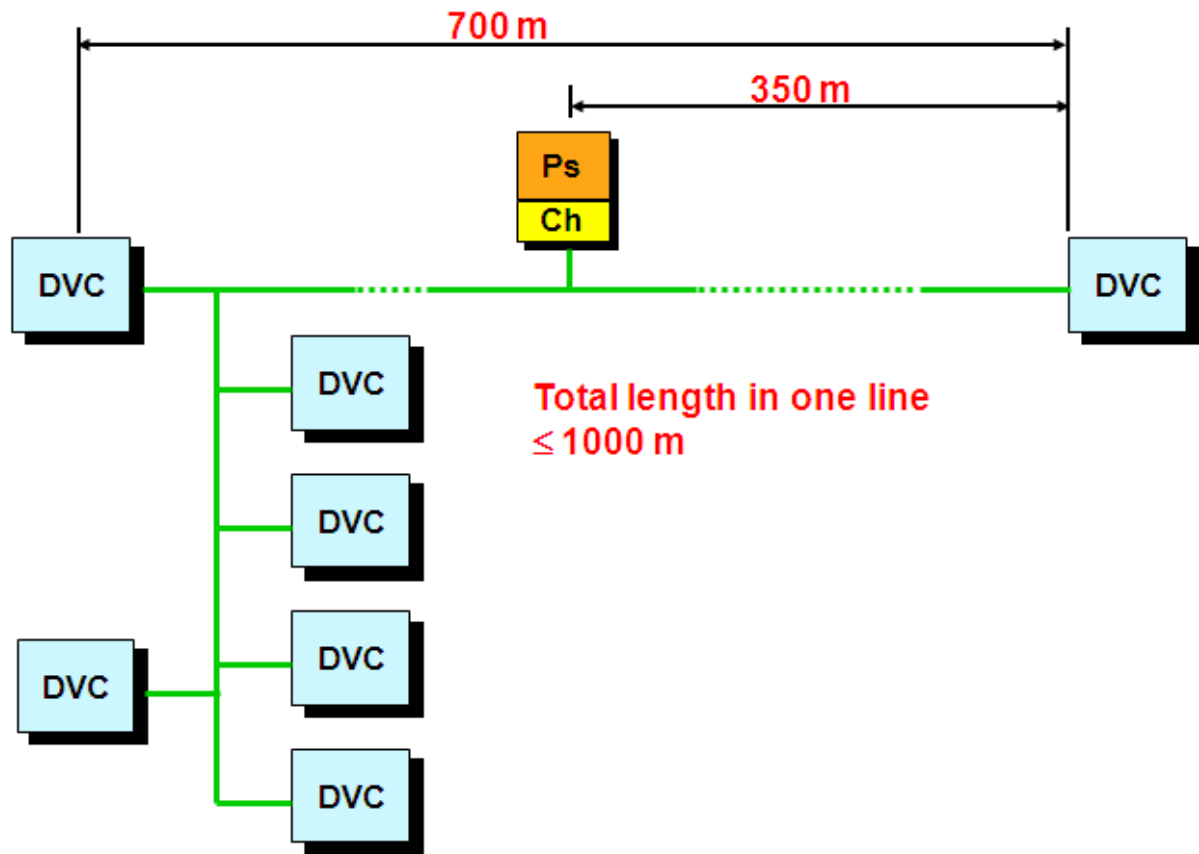

Figure 18: TP1 Cable lengths

## 12 TP1 Cable Lengths

Within a bus line, the following cable lengths are permitted:

- Power Supply Unit - Bus device..... max. **350 m**
- Bus device - Bus device..... max. **700 m**
- Total bus line length..... max. **1000 m**
- Distance between 2 power supply units in one line...**As specified by the manufacturer**

When using a decentralised power supply, please check the chapter 'installation'.

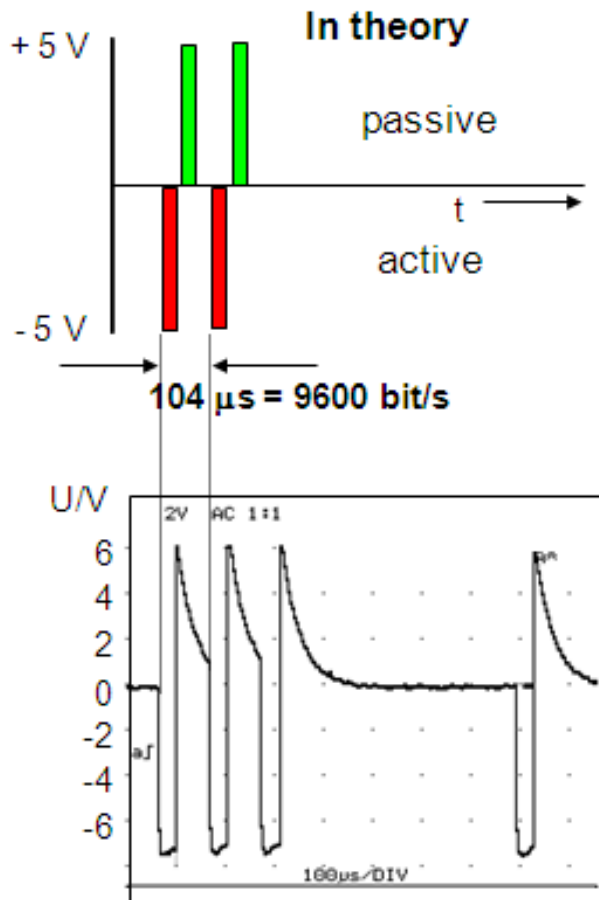

Alternating voltage between the two cables

**Figure 19: Cable Length between TP1 power supply unit and TP1 bus device**

### 12.1 Cable Length between TP1 Power Supply Unit and TP1 Bus Device

The bus device only transmits a half wave (shown in the picture as a negative half wave at the positive core).

The choke as part of the power supply unit produces - together with the transformers of the bus devices - the positive equalisation pulse.

As the choke has a major part in the forming of the equalisation pulse, the bus devices may be installed up to 350 m cable length away from the choke (power supply unit).

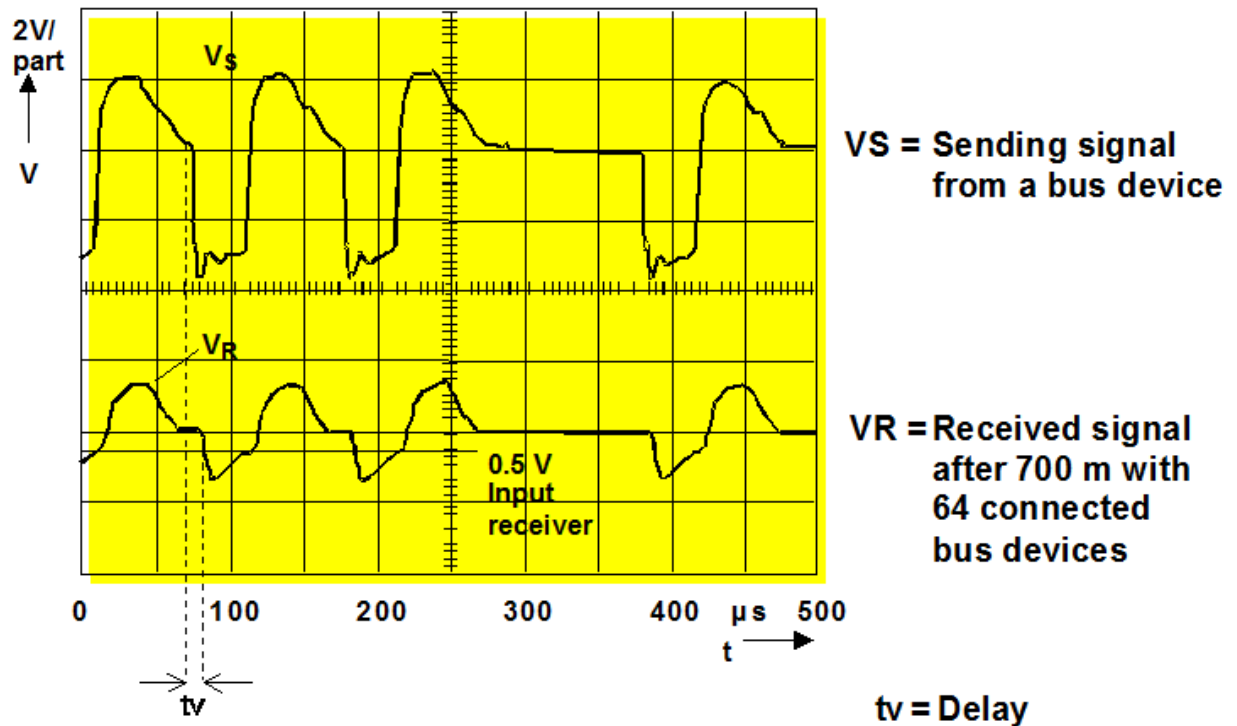

Figure 20: Cable lengths between two TP1 bus devices

## 12.2 Cable Lengths between two TP 1 Bus Devices

A telegram transmission over the cable requires a certain transit time. If several bus devices try to transmit simultaneously, the occurring collision can be resolved up to a distance of 700 m (delay time of the signal  $t_v = 10 \mu\text{s}$ ).

## 12.3 Total Cable Length per TP 1 Line Segment

The signal of the sending bus device will be damped by the continuous loading and unloading of the cable capacity. At the same time, the signal edges are rounded by the cable capacity. The signal level drops due to the resistive load (bus cable and device) of the signal.

To enable the data to be reliably transmitted despite these two effects, the total cable length per line segment may not exceed 1,000 m and the maximum number of devices per line segment may never exceed 64 (regardless of the used power supply unit type).

# KNX TP1 Topology

KNX Association

## Table of Contents

1	Topology – Overall view .....	3
2	Topology .....	4
3	Topology: Area .....	5
4	Topology: Several Areas .....	6
5	Individual address .....	<b>Error! Bookmark not defined.</b>
6	Coupling Unit: Gate Function .....	8
7	Coupler: Block Diagram .....	9
8	Coupling Unit: Types and Functions .....	10
9	Coupling Unit: Fields of Application .....	10
10	Connecting Several Lines .....	11
11	Practical Example for explanation of functionality .....	12
12	Internal Line Telegram .....	13
13	Line-crossing Telegram .....	14
14	Area-crossing Telegram .....	15
15	Coupling Unit: Routing Counter .....	16
16	KNX – Internal and External Interfaces .....	17
17	Topology – Structure in building .....	18
18	Taking into account higher telegram rates: IP Network .....	20
19	Limits to the use of IP routers .....	22

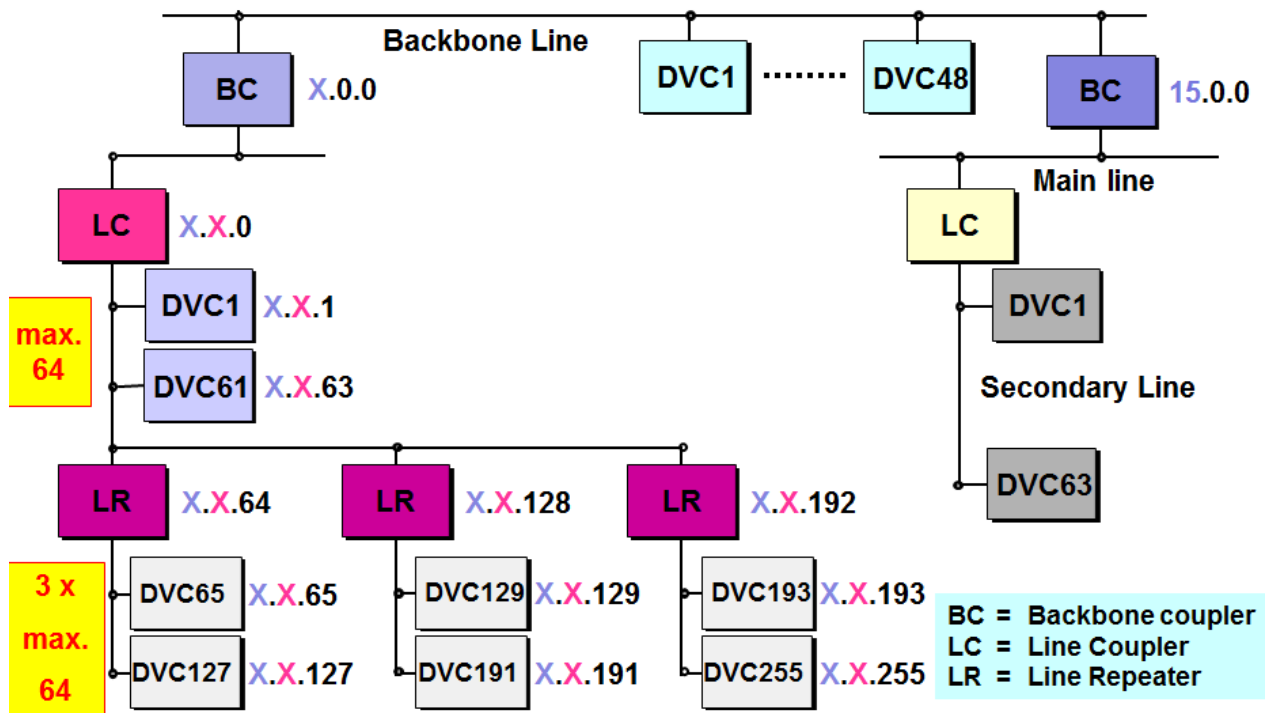

Figure 1: Maximum topological size of a KNX TP installation

## 1 Topology – Overall view

In the figure above the maximum topological size of a KNX TP installation is shown.

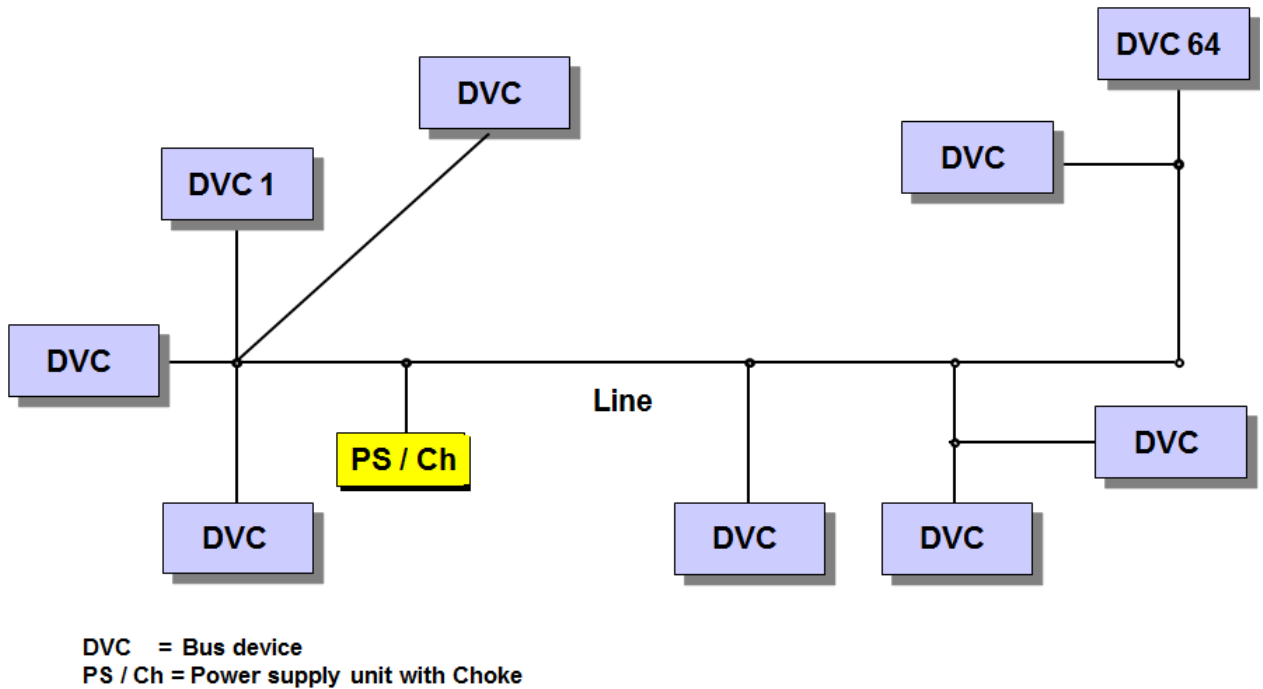

Figure 2: Topology - Line

## 2 Topology

Each bus device (DVC) can exchange information with any other device by means of telegrams.

One line consists of a maximum of 4 line segments, each with a maximum of 64 bus devices. Each segment requires an appropriate power supply.<sup>1</sup>

The actual number of devices is dependent on the power supply selected and the power input of the individual devices.

<sup>1</sup> This chapter assumes the use of central power supply units only. For distributed power supply units, consult chapter 'TP1 installation'.



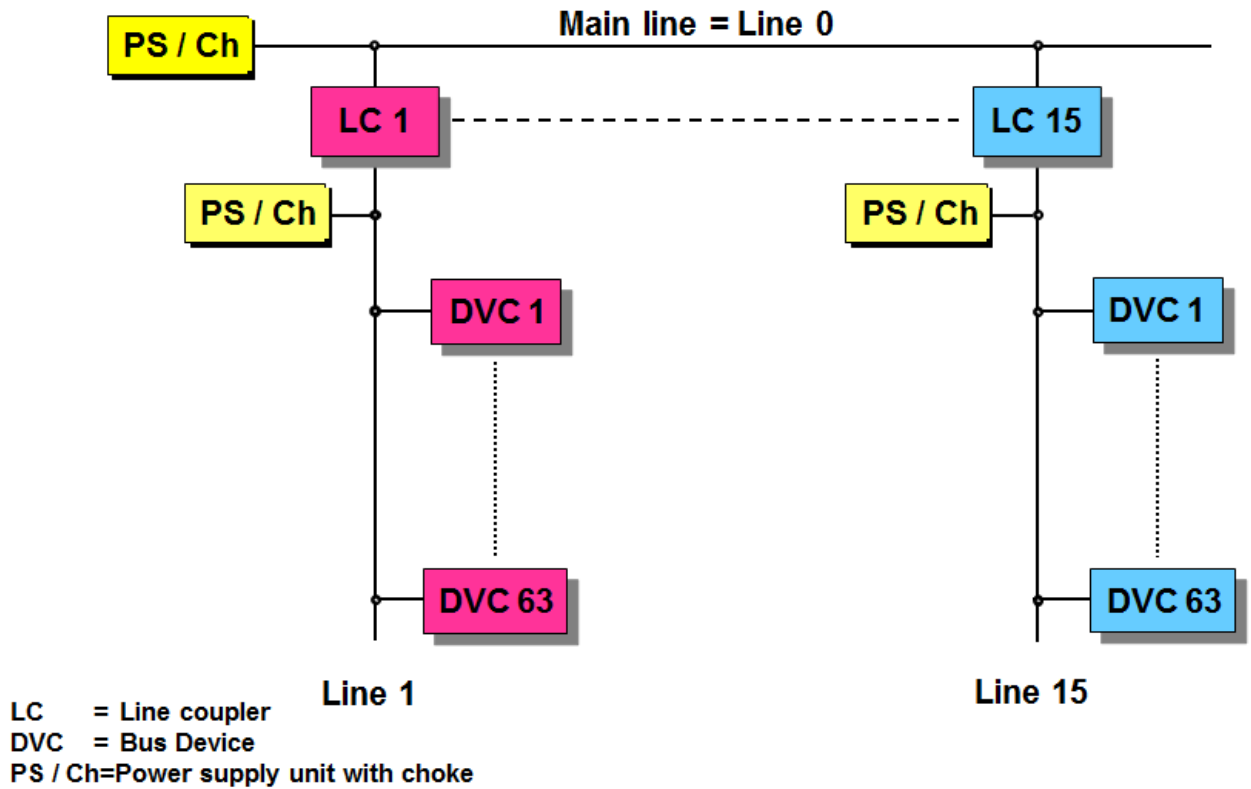

Figure 3: Topology - Area

### 3 Topology: Area

If more than 1 line is to be used or if a different structure is to be selected, then up to 15 lines can be connected to a main line via a line coupler (LC). This is called an area.

It is also possible to have up to 64 bus devices on the main line. The maximum number of bus devices on the main line decreases by the number of line couplers in use.

Each line, including the main line, must have its own power supply unit.

Line repeaters may not be used on backbone or main lines.

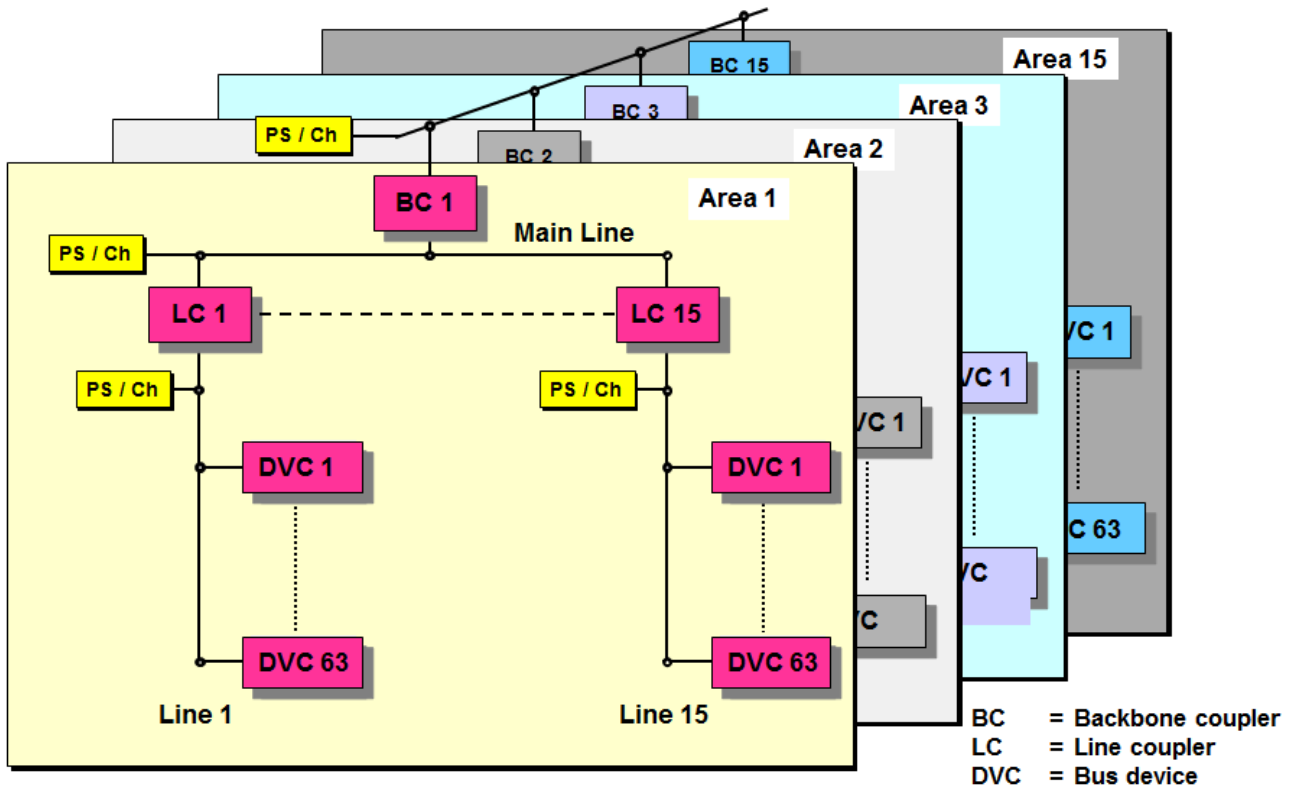

Figure 4: Topology - Several areas

## 4 Topology: Several Areas

The KNX TP1 bus can be expanded by means of a backbone line.

The backbone coupler (BC) connects its area to the backbone line.

It is also possible to have bus devices on the backbone line. The maximum number of bus devices on the backbone line decreases by the number of backbone couplers in use.

Within a maximum of 15 functional areas, more than 58,000 bus devices can be connected to the bus system.

By dividing the KNX TP1 installation into lines and areas, the functional reliability is increased considerably.

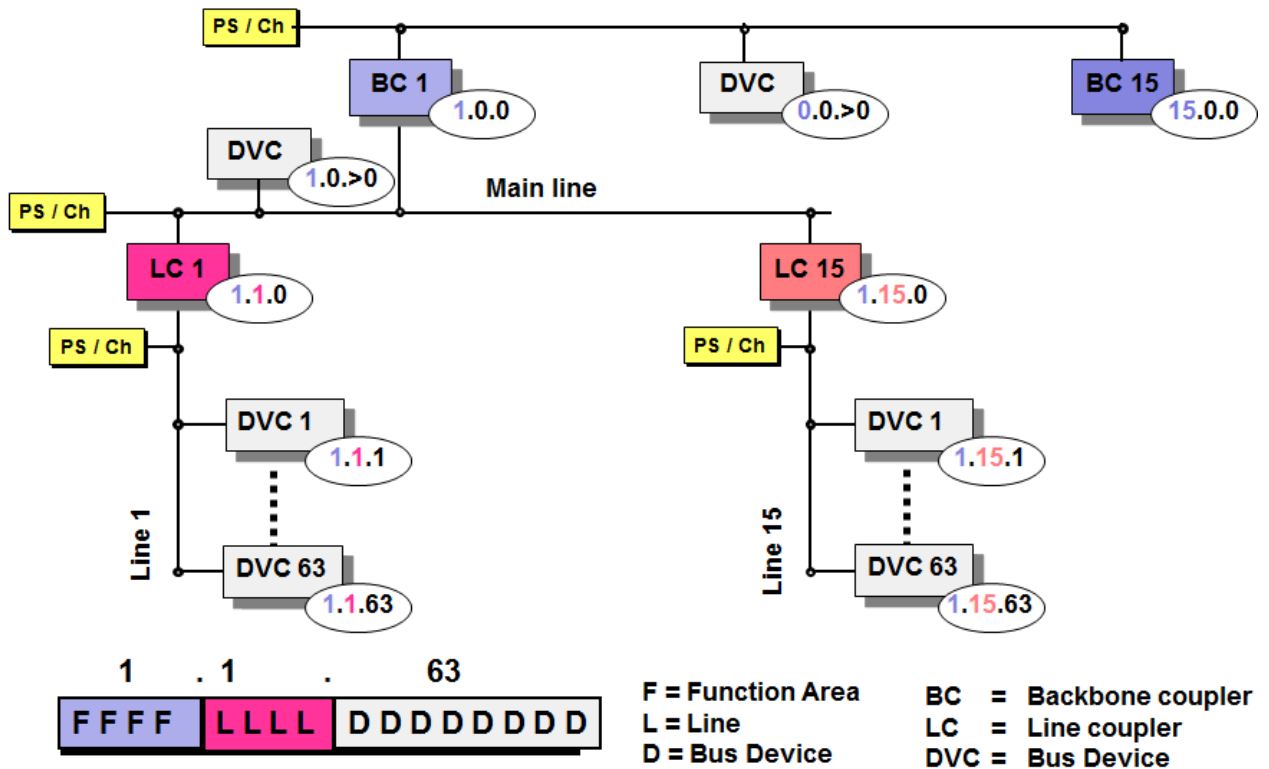

Figure 5: Individual address

## 5 Individual address

The individual address serves to clearly identify the bus device and describes its location within the topology.

- F = 1-15            addresses the areas 1-15
- F = 0              addresses the bus devices on the backbone line
  
- L = 1-15           addresses the lines 1-15 in the areas defined by F
- L = 0              addresses the main line
  
- D = 1-255         addresses the bus devices on the line defined by L
- D = 0              addresses the coupler

The address of an unloaded bus coupler is 15.15.255.

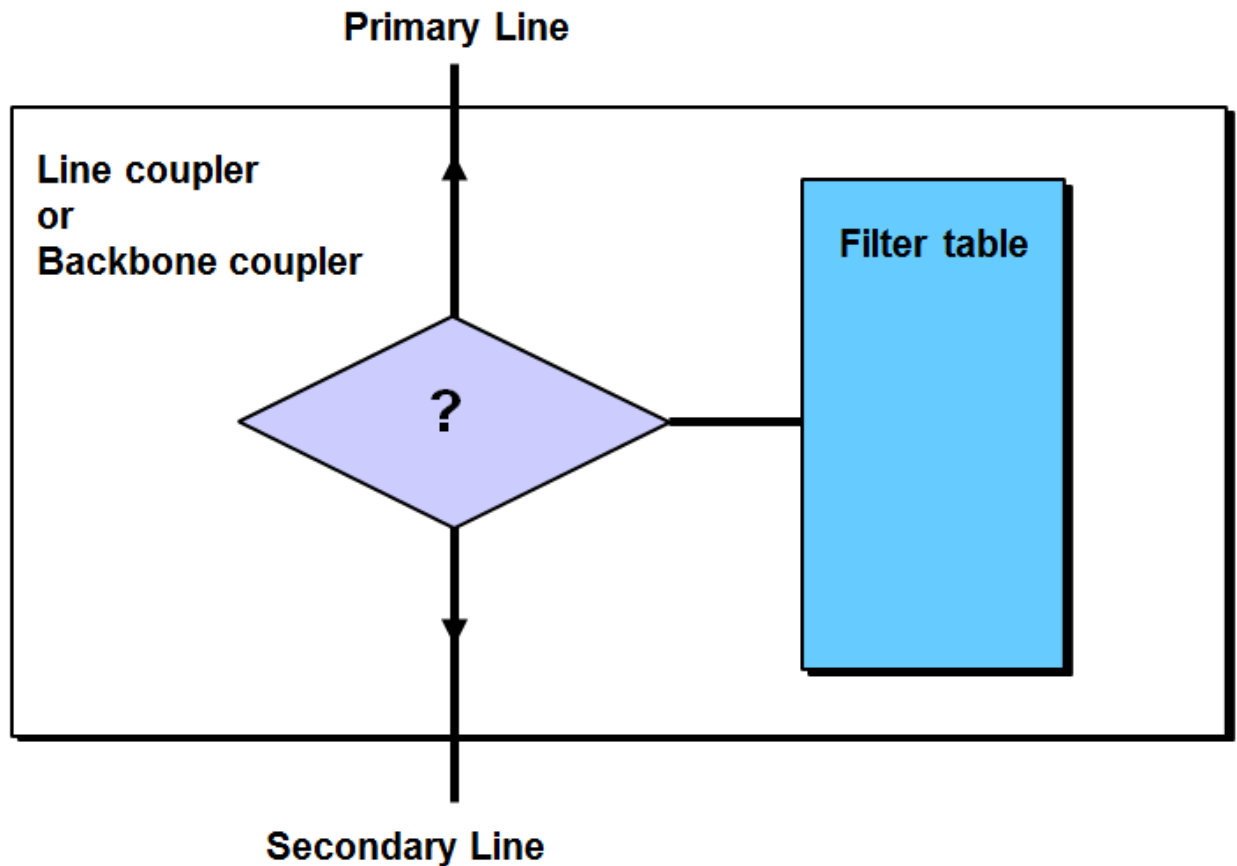

Figure 6: Coupling unit: Gate function

## 6 Coupling Unit: Gate Function

When the parameters are assigned, the coupling unit is provided with a filter table. All received group telegrams are routed if they are listed in the filter table. In this way, each line works independently. Only line-crossing telegrams are routed. The yellow LEDs of the coupler flicker when a telegram is received on the respective line. The line repeater passes on all telegrams; it has no filter table.

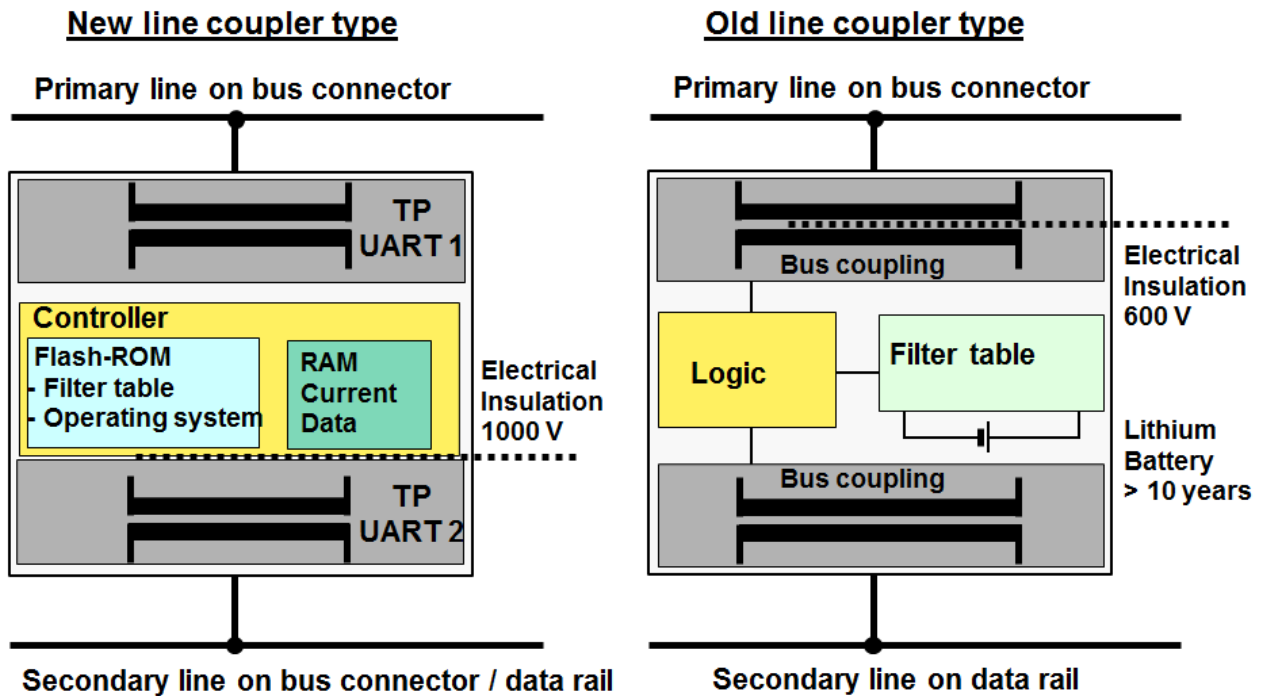

Figure 7: Coupler: Block Diagram

## 7 Coupler: Block Diagram

The coupler is designed for DIN rail mounting. The primary line is connected via a bus terminal.

The secondary line is connected through the data rail or via a bus terminal. New types of couplers (from July 2003 onwards) can be programmed from both the secondary as well as the primary line.

In the old line coupler type (until June 2003), the secondary line supplies the power for both bus coupling units, the logic and the filter table memory.

The new coupler has only 1 controller and is supplied by the primary line. This has the advantage, that the coupler can report secondary line power cuts.

A lithium battery with a life span of more than 10 years (also without connection to the bus) provides the backup supply for the memory containing the filter table in the old line coupler type. The new type is equipped with a Flash ROM memory, which does not need backup battery power. The coupler electrically isolates the lines from each other as ruled by SELV standard.

## 8 Coupling Unit: Types and Functions

The coupling unit can be used as:

### Backbone coupler BC

Connection: Backbone line to Main line

### Line coupler LC

Connection: Main line to Secondary line

### Line repeater LR

For expanding a line by a line segment with up to 64 additional bus devices and an additional cable length of 1,000 m.

Bus and line couplers only pass on line-crossing telegrams, whereas a line repeater passes on all telegrams.

Backbone coupler, line coupler and line repeater are identical devices. The tasks to be carried out are dependent on the location and the corresponding designated individual address.

#### Individual Address



			The coupling unit is used	
			as	for
> 0	= 0	= 0	Backbone Coupler	Backbone line/main line
> 0	> 0	= 0	Line Coupler	Main line/secondary line
> 0	> 0	> 0	Line Repeater	Line expansion

Figure 8: Coupling unit: Fields of application

## 9 Coupling Unit: Fields of Application

It is the assigned individual address that designates a coupler either as a backbone coupler, a line coupler or a line repeater. The address 1.1.0, for example, defines a coupling unit as the line coupler for line 1 in area 1.

The coupler monitors data communication between main line and secondary line and vice versa. Only the telegrams of which the group addresses are stored in its filter table are routed.

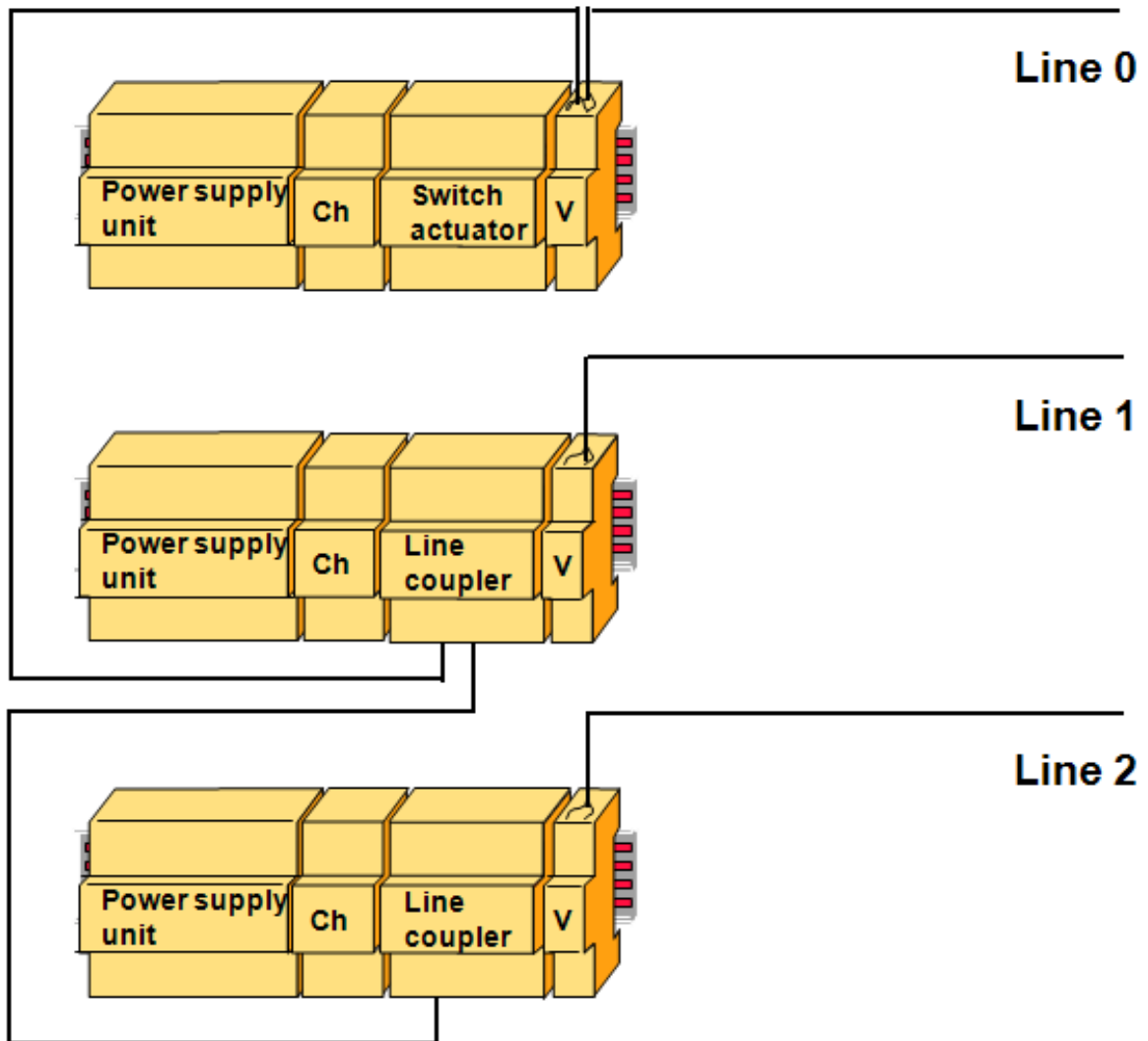

Figure 9: Connecting several lines

## 10 Connecting Several Lines

In an installation comprising several lines, each line must have its own power supply unit and choke.

The above figure shows a power supply unit with separate choke as well as a line coupler of the former generation (wide design).

The secondary line (e.g. line 1) is connected via pressure contacts or via a bus terminal onto the data rail. The primary line (line 0) is connected by means of bus terminals.

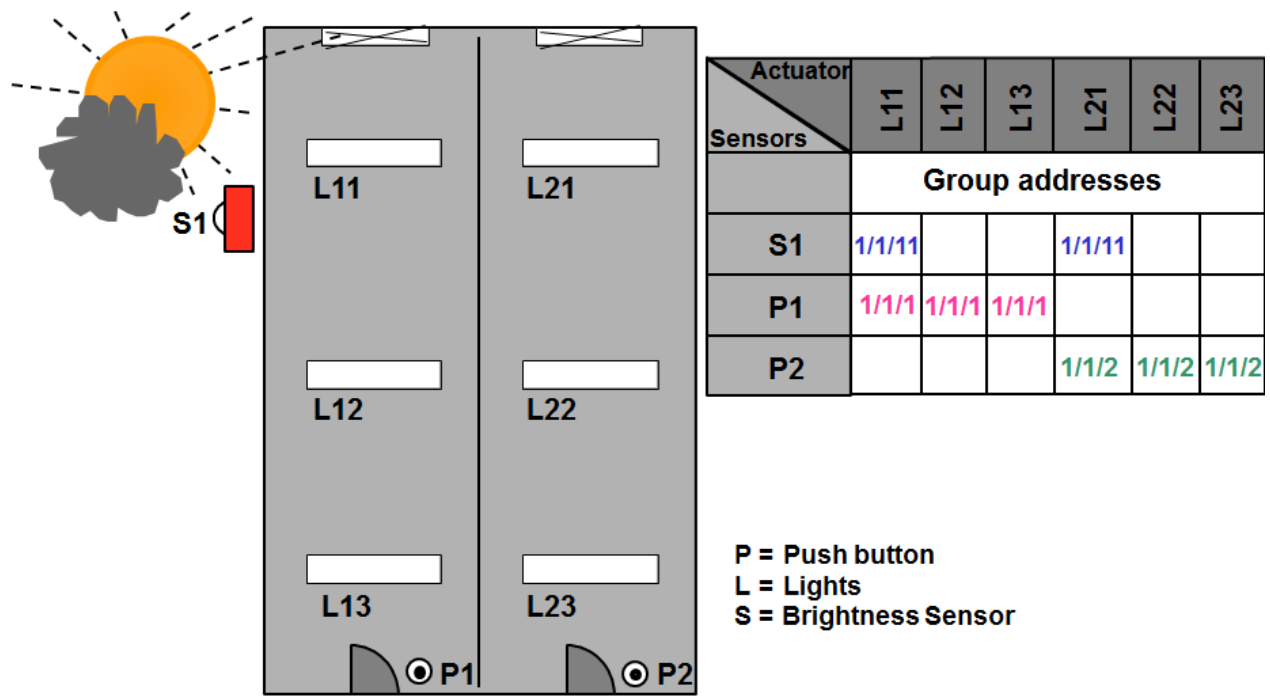

Figure 10: Practical example

## 11 Practical Example for explanation of functionality

The push button T1 shall switch the lights L11, L12 and L13.

During Configuration, Group address 1/1/1 is attributed to the push button. The same address is also attributed to the actuators in the before-said lamps.

The push button T2 shall switch the lights L21, L22 and L23. The group address 1/1/2 is assigned to it. Again the same address is attributed to the actuators of these lamps.

The brightness sensor S1 shall also switch the lights next to the window. Group address 1/1/11 is therefore attributed to the sensor as well as to the actuators controlling the window lights.

The window lights can therefore be switched via the push button as well as the brightness sensor.



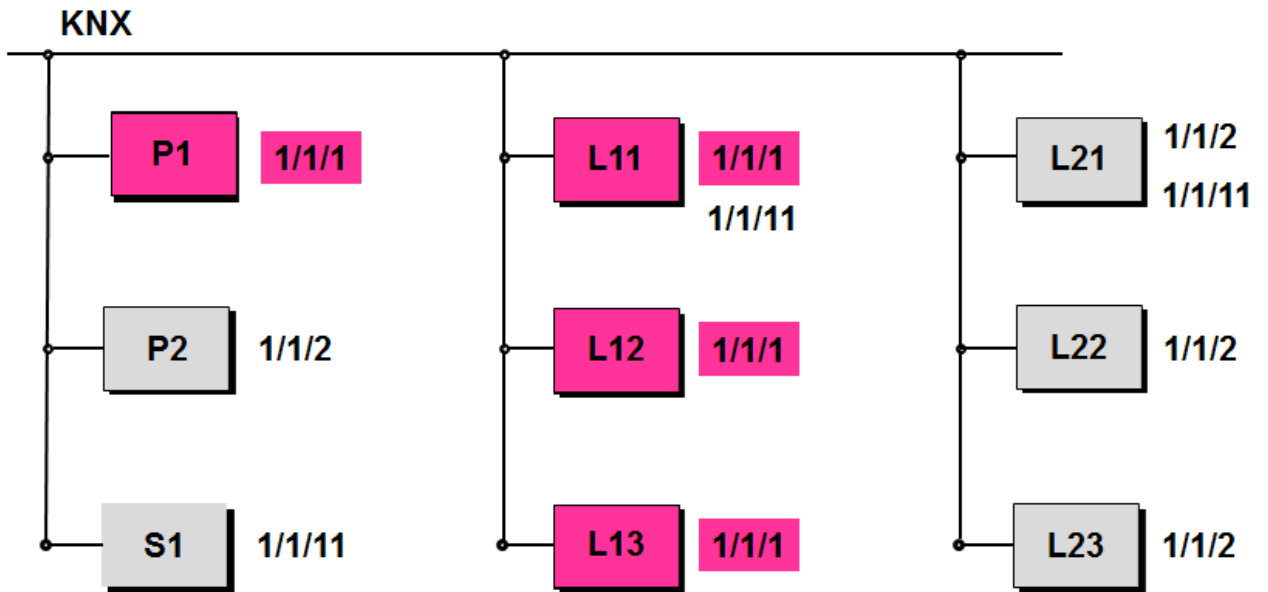

Figure 11: Internal line telegram

## 12 Internal Line Telegram

Pressing push button P1 sends a telegram with the group address 1/1/1.

Although all bus devices listen in when the telegram is transmitted, only the actuators of lamps L11, L12 and L13 with the common group address 1/1/1 execute the command.

If the brightness sensor sends the group address 1/1/11, all the bus devices on this line listen in but only the actuators of the window lamps L11 and L21 execute the command.

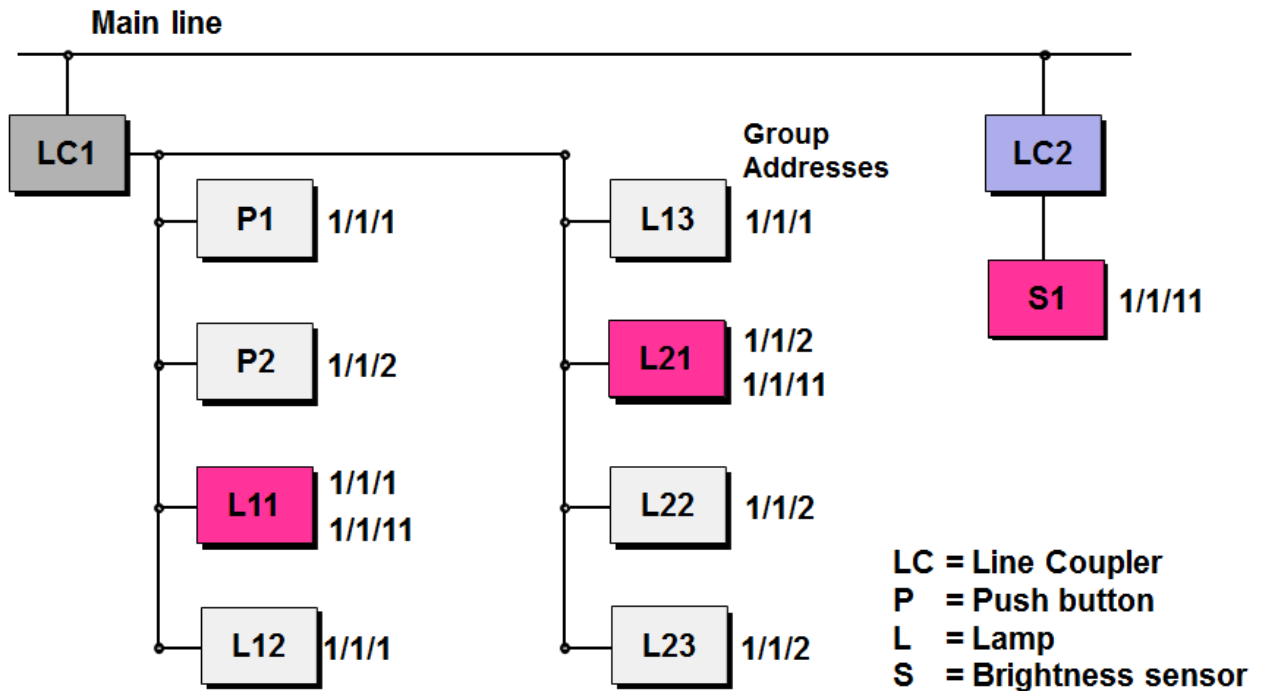

Figure 12: Line-crossing telegram

### 13 Line-crossing Telegram

If the brightness sensor is not connected in the same line as the lamp it has to control, it is necessary to transmit its telegrams via the main line.

The parameters assigned to line coupler LC2 contain all the necessary information for this line coupler. LC2 is thus aware of the fact that there are bus devices outside its own “line 2” which respond to telegrams transmitted by the brightness sensor. LC2 therefore routes the group telegram 1/1/11 onto the main line.

Line coupler LC1 is aware of bus devices on its “line 1” that respond to the group telegram 1/1/11 and therefore transmits the telegram to its line.

All the bus devices on this line listen to the telegram from the brightness sensor but only the actuators of lamps L11 and L12 execute the command.

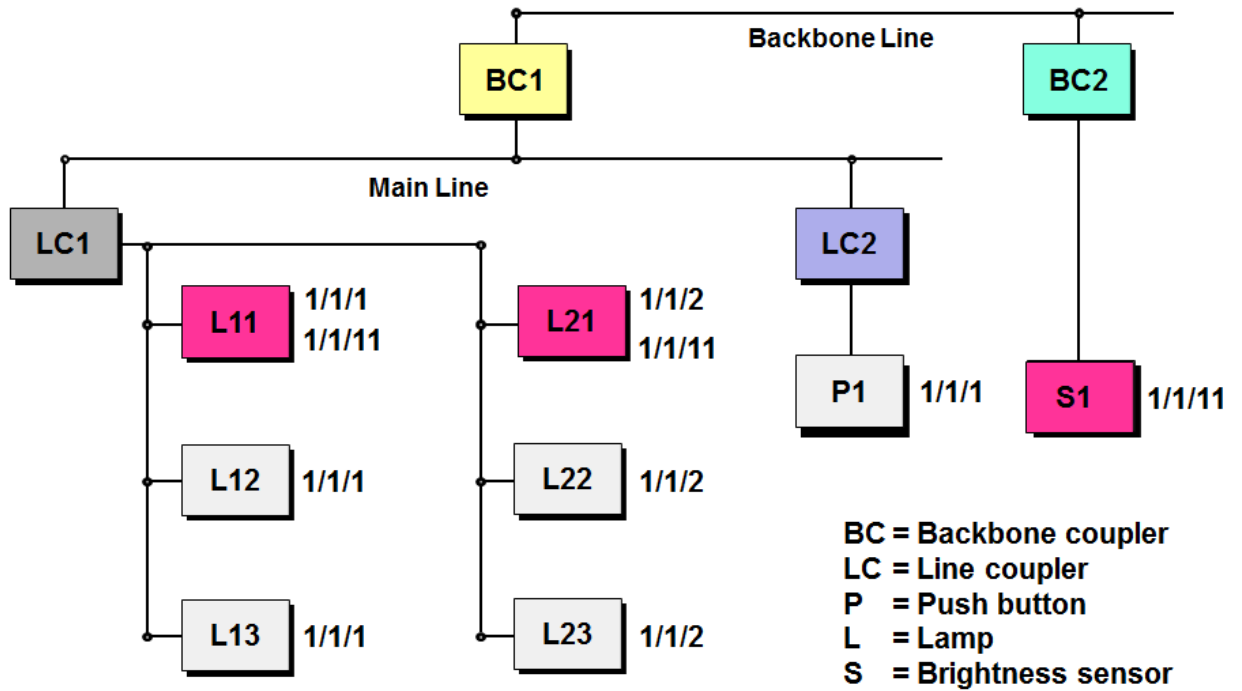

Figure 13: Area-crossing telegram

## 14 Area-crossing Telegram

Even if brightness sensor S1 is assigned to a different function area, it can still address all bus devices through the backbone line.

If the group address 1/1/11 is assigned to the brightness sensor, the telegram is routed to line 1 by backbone couplers BC1 and BC2 and line coupler LC1.

The actuators of lamps L11 and L21 in function area 1/line 1 then execute the command.

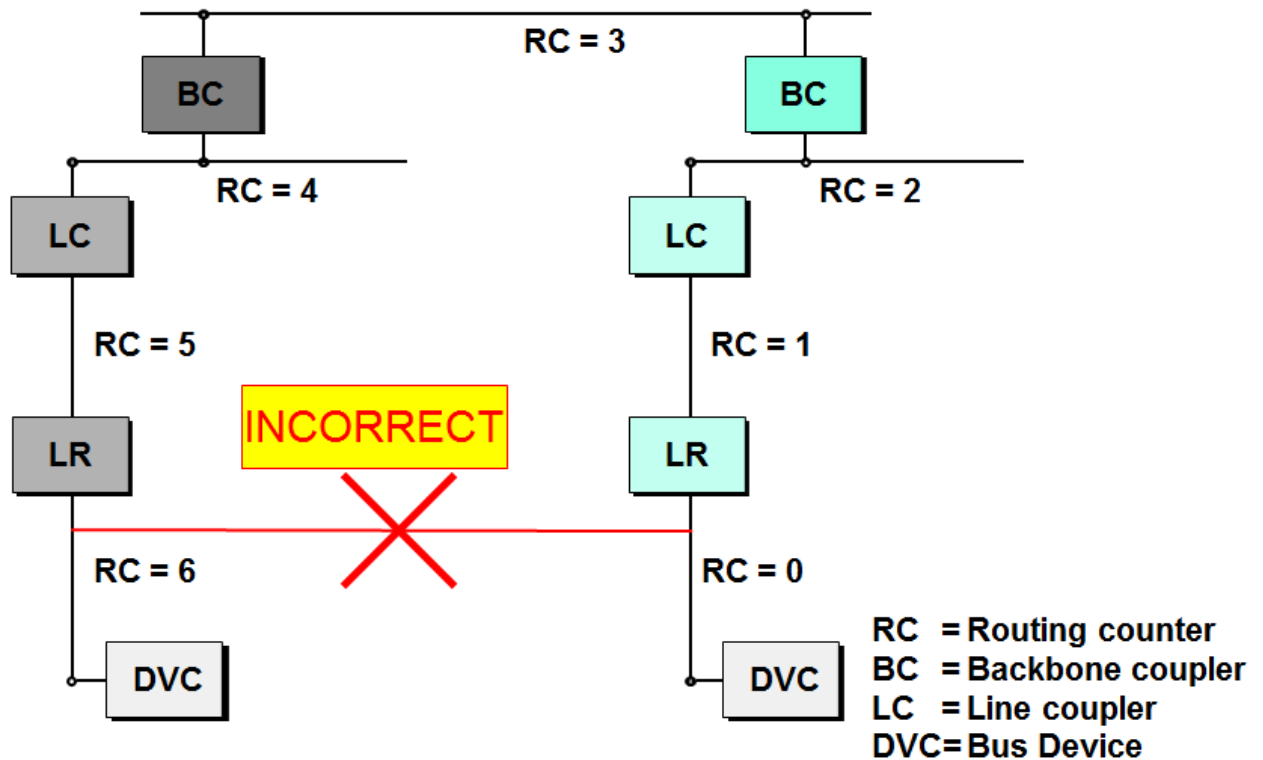

Figure 14: Coupling unit: Routing counter

## 15 Coupling Unit: Routing Counter

The telegram transmitted by the sending device contains a routing counter, of which the initial count value is 6.

Each coupler decrements the routing counter and passes on the telegram as long as the value is not 0. The filter table entries are observed.

If the service device, for example, transmits a telegram containing a routing count value of 7, the coupling units do not alter this value. In this case the filter table is ignored and all line couplers in the installation route the telegram. It finally reaches the bus devices it is intended for, no matter which line they are connected to.

If the installation has a line-crossing structure, the routing counter limits the number of telegrams that cross lines.

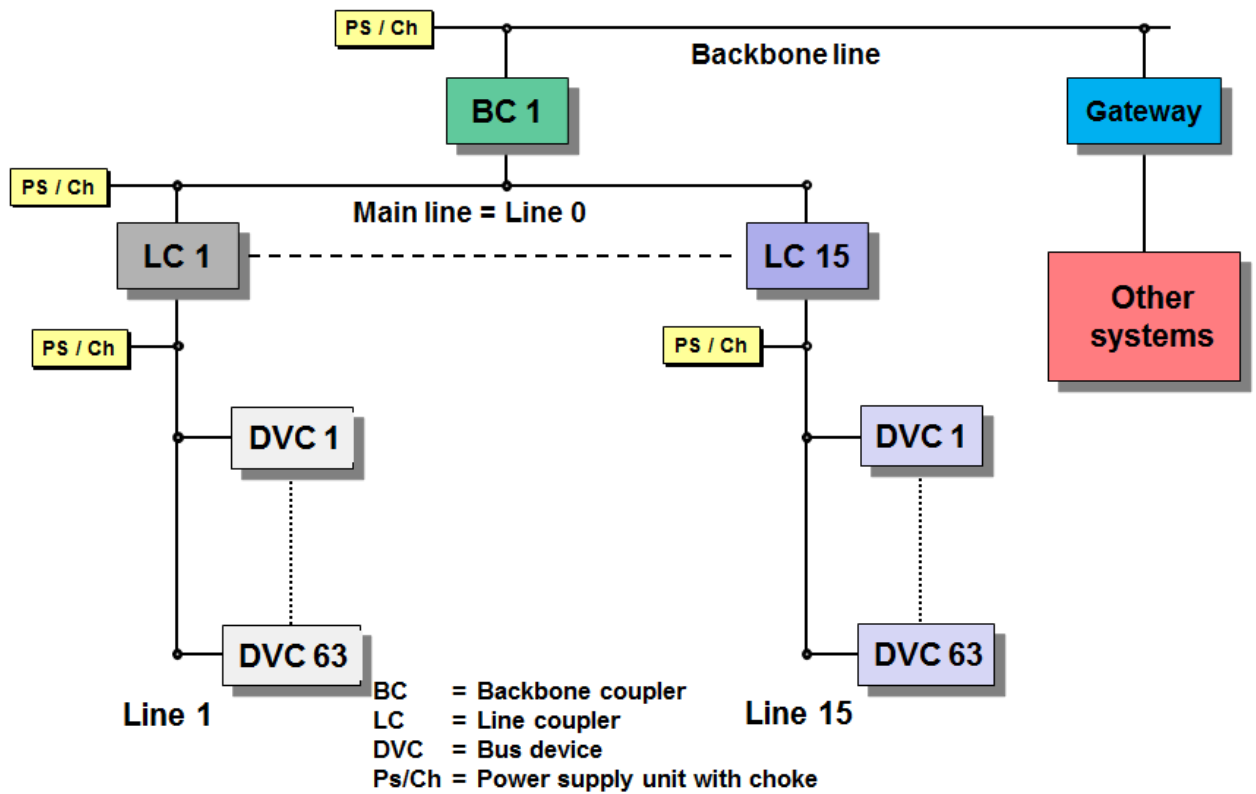

Figure 15: KNX - Internal and External Interfaces

## 16 KNX – Internal and External Interfaces

KNX is open to any other system. The backbone line (or any other line) can be connected via a gateway unit to e.g. SPS, ISDN, building management technology, Internet etc.

The gateway unit carries out a bi-directional conversion of the protocol.

The respective media couplers connect KNX media of different types (e.g. Twisted Pair 1 and Power Line 110).

Parts of KNX installations can also be linked via optical fibres. The benefits of this are electrical isolation and greater cable lengths.

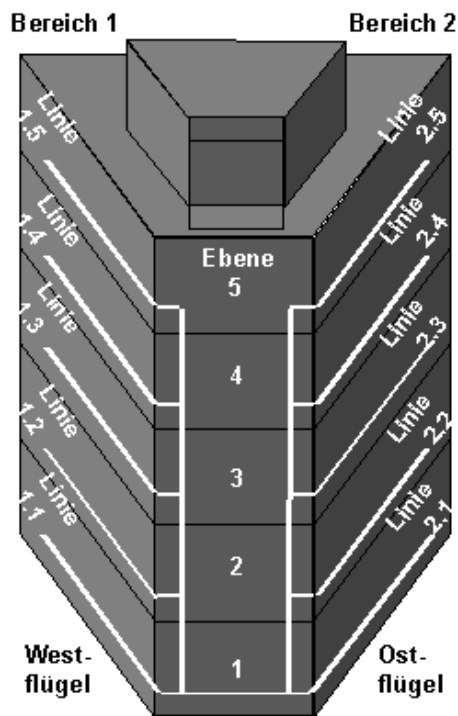

Area		Line	
No.	Comment	No.	Comment
0	Area 0	0	Backbone line
1	West wing	0	Main line West
		1	1st floor
		2	2nd floor
		3	3rd floor
		4	4th floor
2	East wing	0	Main line East
		1	1st floor
		2	2nd floor
		3	3rd floor
		4	4th floor
		5	5th floor

Figure 16: Division of lines in a medium-sized project (example)

## 17 Topology – Structure in building

After the above theoretical introduction, some practical information (the above picture is by the way explained in detail in chapter “ETS Project Design – Advanced”).

Ideally, a building does not have more than 50 bus devices installed per floor. Or one can – as shown in the above picture, make a division according to the different wings of the building. It is clear that in this case the better overview will be realised when line numbers correspond to floor numbers and area numbers correspond to building - or wing numbers.

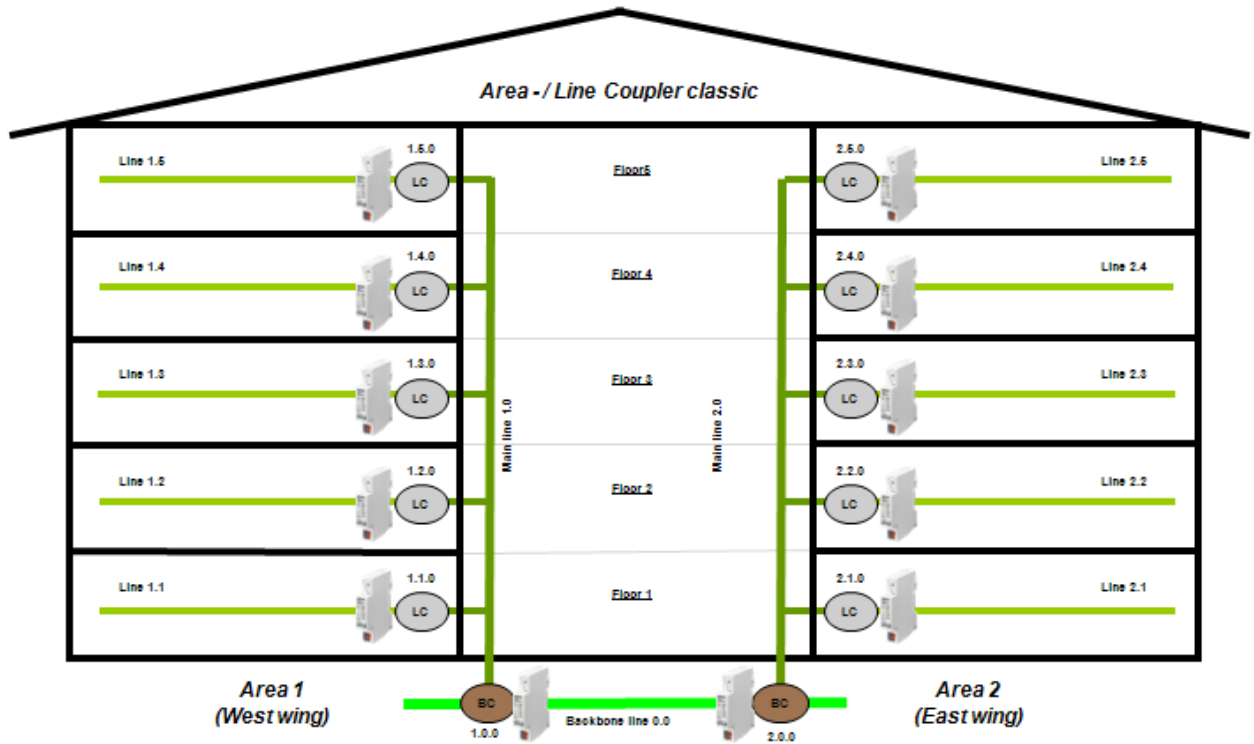

**Figure 17: The above picture is clearer with the required couplers**

Of course it will not be possible to realize this under all circumstances. As line repeaters can be installed (as already indicated before), such a floor may be equipped with up to 253 devices, without having to violate the above structure (taking into account that line repeaters have to be counted double as discussed before, the normal maximum number of devices of 256 is reduced by 3). With that many devices it is possible to realize nearly any application, in view of the current evolution in the development of KNX devices and the availability of input - / output devices with in the mean while more than 16 channels.

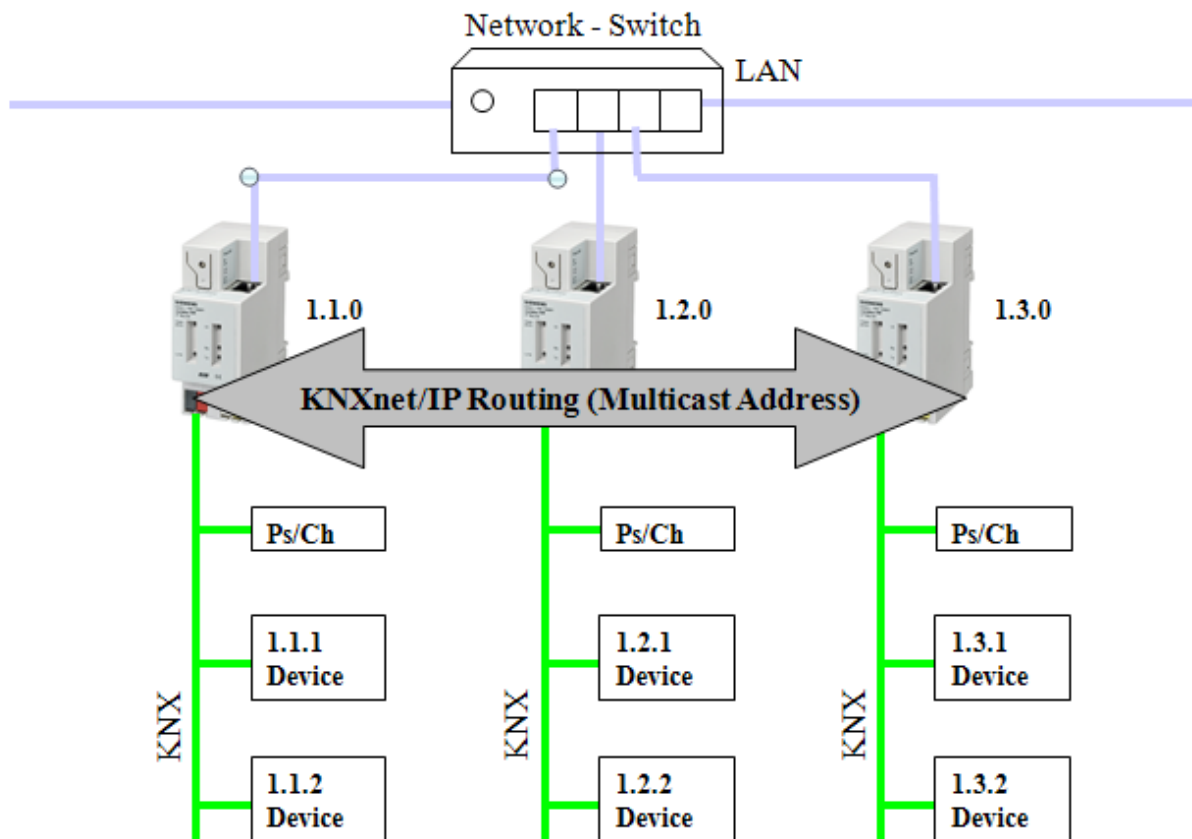

Figure 18: Replacing line couplers by so-called “IP Routers”

## 18 Taking into account higher telegram rates: IP Network

As explained in the previous paragraph, on all levels gateways to other systems can be installed. Increasingly, this is demanded in bigger projects as a result of higher customer demands.

An important reason is the increased telegram load, which can occur when the user makes use of visualisation software and devices with a higher number of channels, all of which automatically returning multiple status acknowledgements. In the latter case, a pure TP topology is overloaded due to the fact that transmission speed on main – and backbone lines is limited to 9,6 kBit / sec. In such a case one can easily use an IP network as a substitute for main – or backbone lines, by using the coupler that was designed for this purpose.

As you can see from above picture, the main line has been replaced by an IP network. This has the advantage that all vertical operations e.g. the (bi-directional) communication between a building central and KNX is only determined by the bit rate of the secondary line (Ethernet is at least 1000 times faster; with the so-called “Gigabit” – switches it is possible to transmit data on the Ethernet 100 000 times faster). The parallel connection of several lines is no longer an issue. The standardized type of communication applied here is called “Tunnelling”. It is in other words the well-known gateway function, which is also



used by ETS for remote programming across IP. A building central can be connected simultaneously to several gateways, multiplying the total data rate.

A different story is the direct communication between the individual KNX lines. The IP router makes use of another procedure which is called “routing”, or the actual line coupler function. Principally it works in the same way as routing across a TP main line: An IP router wanting to send a line-crossing telegram, will send this with a so-called “Multicast” IP address into Ethernet. All other IP routers are connected to this multicast address, and are able to receive and evaluate this telegram. The normal line coupler function is now again applied, i.e. the comparison with the compulsory filter table (group telegrams) or the line address (individual addressed telegrams) resulting in the ad hoc blocking or routing of telegrams.

Please note the following with regard to multicast addresses:

- There is a dedicated worldwide registered KNX multicast address, which is pre-programmed in the software of the IP router. This multicast address can be changed within the limits of the available address range for IP communication.
- The network switch and area router in the LAN network must be fit to handle multicast telegrams. In case of doubt you should discuss this matter in advance with your network administrator.
- The multicast addresses cannot be used across Internet, except across a VPN connection.

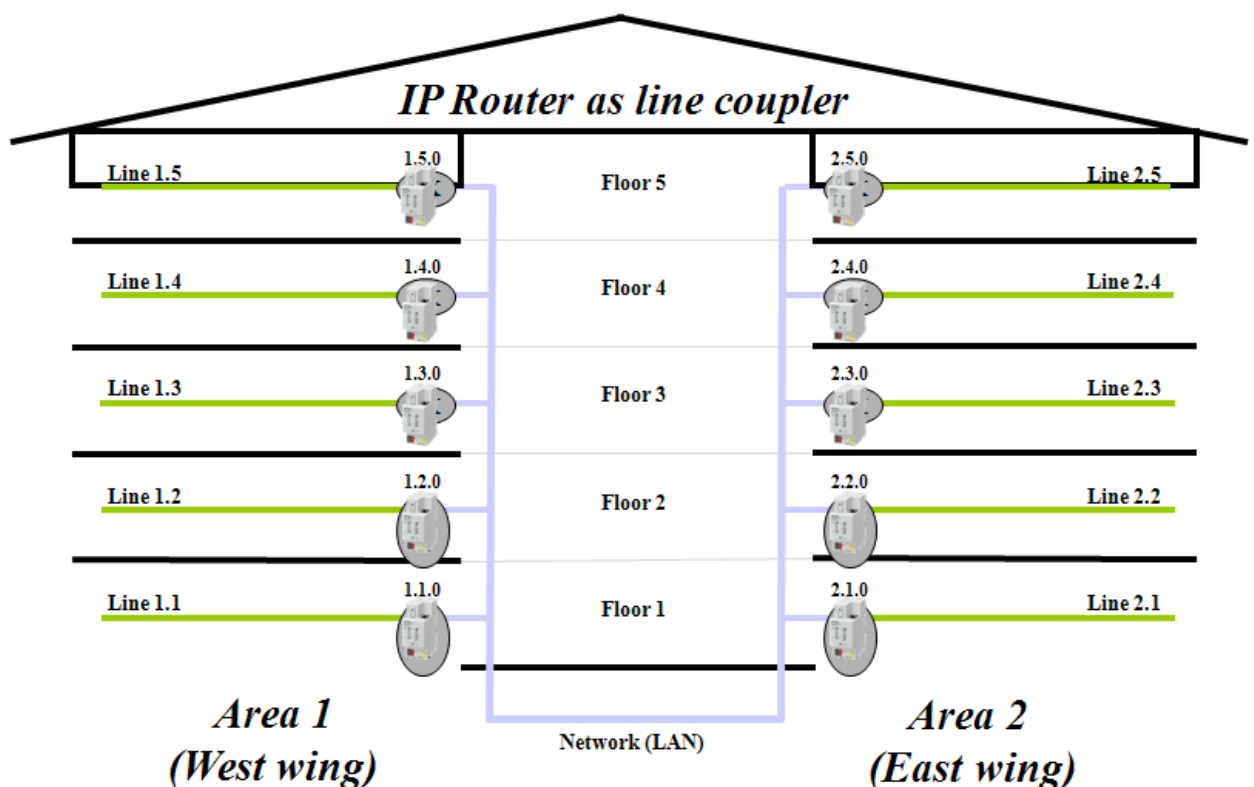

Our picture again: line couplers have now been replaced by IP routers. This picture represents the underneath explained case 1.

Just like the TP/TP coupler, the IP router can be used as a line coupler as well as a backbone coupler. If the IP router replaces the line coupler, all main lines and basically also the backbone line are replaced by Ethernet. (Case 1).

If backbone couplers are replaced by IP routers, the normal line couplers can remain, as only the backbone line is replaced by the LAN (case 2).

Which case is more appropriate depends more or less on the to be expected telegram rate requirements on main – and backbone lines. Theoretically, a third case is possible, as a combination of case 1 and 2, with normal TP areas with an IP router on top and also with lines with IP routers instead of line couplers. This option should however be chosen in exceptional cases. The topic is described in more detail in the KNX advanced course.

## 19 Limits to the use of IP routers

Even if the high bit rate of Ethernet considerably facilitates heavy telegram traffic and minimizes telegram loss, one should warn not to thoughtlessly program bus devices sending out telegrams too frequently. The fast Ethernet will not help if for instance telegrams are sent out simultaneously from all lines into one single line. To explain it with a metaphor: the case would be similar to all cars accessing a 1000 lane motorway via 100 entries but all of them also wanting to exit via a single lane exit. This is by the way not a KNX related problem it is common to all mesh structured data networks.

Only a meaningful organisation of communication between bus devices and lines will be able to prevent a very unlikely but still possible loss of data.

This however should be easily possible with sufficient knowledge on bus devices and their respective parameters.

# KNX Bus Devices

KNX Association

## Table of Contents

1	Introduction .....	3
2	Internal structure of a Bus Coupling Unit.....	5
3	Type Definition of an Application Module .....	8
4	Overview of principal KNX standardised system profiles.....	9
4.1	System 1 (TP1/PL110) – TP1 System 2 – TP1 System 7.....	9
4.2	System 2 and System 7 Characteristics .....	10
4.2.1	Access control.....	10
4.2.2	Serial number .....	10
4.2.3	Interface Objects .....	10
5	Application Function: Dimming with Start/Stop Telegram.....	11
6	Dimming with Cyclical Telegrams.....	12
7	Application Function: 'Dimming Actuator' .....	13
8	Application: Drive Control Sensor.....	14
9	Application: Drive Control.....	15
10	Drive Control Object Structure .....	16

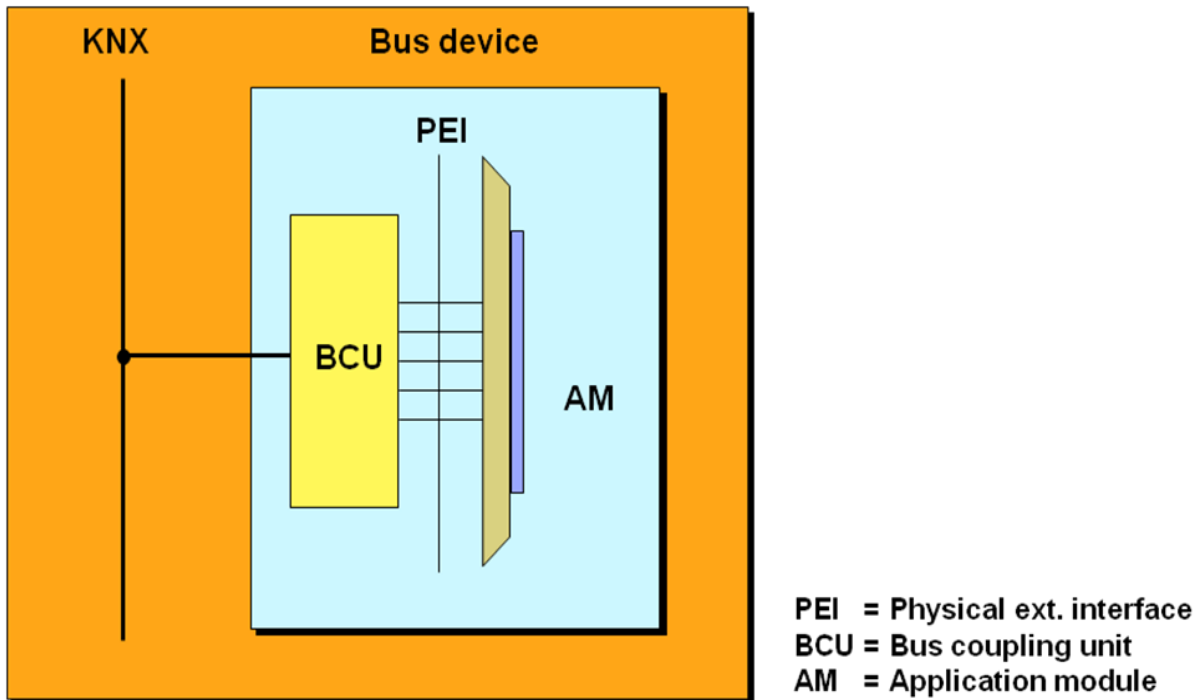

Figure 1: Bus device

## 1 Introduction

A functioning bus device (e.g. dimming actuator/drive control, multi-functional push button, fire sensor...) principally consists of three parts:

- ✚ bus coupling unit (BCU)
- ✚ application module (AM)
- ✚ application program (AP)

Bus coupling units and application modules are offered on the market either separated or integrated into one housing. They must however be from the same manufacturer. If separated, the application module is connected to the BCU via a standardised application interface, the Physical External Interface or PEI. This 10 or 12 pin PEI serves as

- ✚ an interface to exchange messages between both parts (5 pins)
- ✚ the power supply of the application module (2 pins)

Some application modules can only be connected to a specific BCU type. When the bus coupling unit is a separate part of the bus device, it is mostly available in a wall mounted design. In case of TP1 devices, the connection to the bus is mostly ensured via the standardised bus terminal (dark grey/red); in case of DIN rail devices via contact blocks to the data rail.

When the BCU is an integrated part of the bus device, it has mostly been built into the bus device via a BIM (Bus Interface Module) or via a chip set by the manufacturer of the bus device. Principally a BIM is derived from a bus coupling unit by omitting the latter's

housing and a number of other components. A chip set consists of the core of a BIM, i.e. the controller and the transceiver<sup>1</sup>.

BCUs are currently available for connection to two different media: Twisted Pair 1 (Safety Extra Low Voltage 32V) or Powerline 110 (mains power). A RF BCU is not available: KNX RF compatible devices are integrated solutions.

Each bus device has its own intelligence owing to the integrated BCU: this is the reason why KNX is run as a decentralised system and does not need a central supervising unit (e.g. a computer). Central functions (e.g. supervision) can however if needed be assumed by visualisation and control software installed on PCs.

Bus devices can principally be divided into three classes: sensors, actuators and controllers.

- ✚ In the case of a sensor, the application module transfers information to the BCU. The latter codes this data and sends it on the bus. The BCU therefore checks the state of the application module at appropriate intervals.
- ✚ In the case of an actuator, the BCU receives telegrams from the bus, decodes them and passes on this information to the application module.
- ✚ A controller will influence the interaction between sensors and actuators (e.g. logical module).

In case of S-mode compatible KNX devices, a device receives its specific function once the appropriate application program for the application module has been loaded into the (universal) BCU (via the ETS™). An S-mode compatible KNX push button mounted on a BCU can only generate dimming signals, after the suitable application program has been programmed in the device via the ETS.

In case of E-mode compatible KNX devices, a device is normally shipped with loaded application program. The linking of such KNX devices and the setting of the relevant parameters is either ensured via appropriate hardware settings or via a central controller.

---

<sup>1</sup> This can be a discrete solution, an ASIC or in case of TP 1, the so called TP-UART.

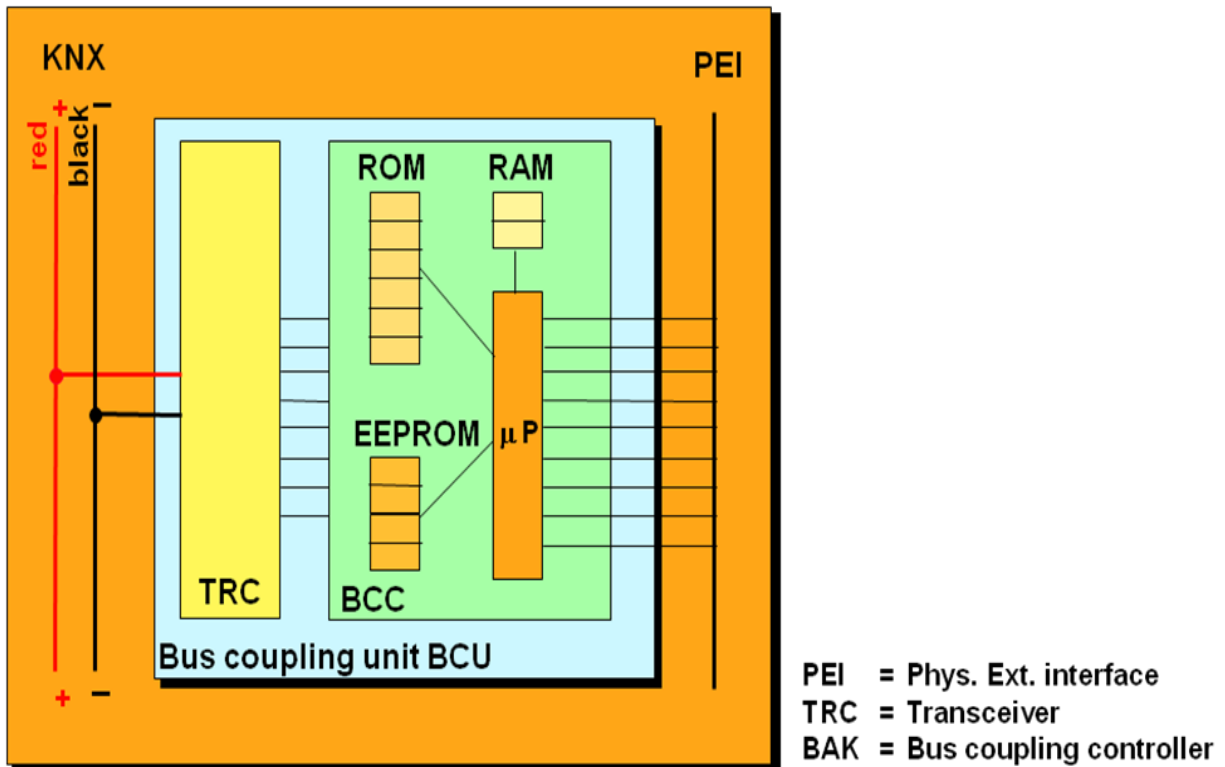

Figure 2: Internal structure of a bus coupling unit

## 2 Internal structure of a Bus Coupling Unit

A KNX BCU principally consists of two parts: a controller and a transceiver suitable for the connected medium. In the different types of a memory of the microprocessor ( $\mu P$ ) inside the controller, the following data is stored:

- ✚ The system software: the different standardised KNX system software profiles are identified by their “mask version” or “device descriptor type 0”. The mask version consists of 2 bytes where
  - the first digit **y** refers to the corresponding medium – 0 for TP1, 1 for PL110, 2 for RF and 5 for KNXnet/IP. All software profiles not always contain the previously mentioned media.
  - The last digit **x** refers to the current version of the software profile  
ETS is informed about the underneath mentioned system profiles by the following mask versions:
    - y01xh: System 1<sup>2</sup>
    - y02xh: System 2<sup>3</sup>
    - y70xh: System 7<sup>4</sup>
    - y7Bxh: System B

<sup>2</sup> previously referred to as BCU1

<sup>3</sup> previously referred to as BCU2

<sup>4</sup> previously referred to as BIM M 112

- y300h: LTE
- 091xh: TP1 Line/area coupler – Repeater
- 190xh: Media coupler TP1-PL110
- 2010h: RF bi-directional devices
- 2110h: RF unidirectional devices

Devices based on the latter two system profiles can for the time being not be handled by ETS. The system software is usually stored in ROM or Flash memory and can mostly not be overwritten.

- ✚ temporary values of the system and the application: these are usually stored in RAM memory and lost (if not stored to EEPROM or Flash memory before power loss).
- ✚ the application program, the physical and group addresses: these are usually stored in EEPROM or Flash memory and can be overwritten.

In the case of S-mode compatible devices, the manufacturer makes the application program available to the installer as an ETS database, who then loads it into the device. The manufacturer's code for the application program and the bus coupling unit must be identical to be able to load the application program.

In case of E-mode devices, the device will report its supported functionality (as regards supported easy channels) by means of the device descriptor 2.



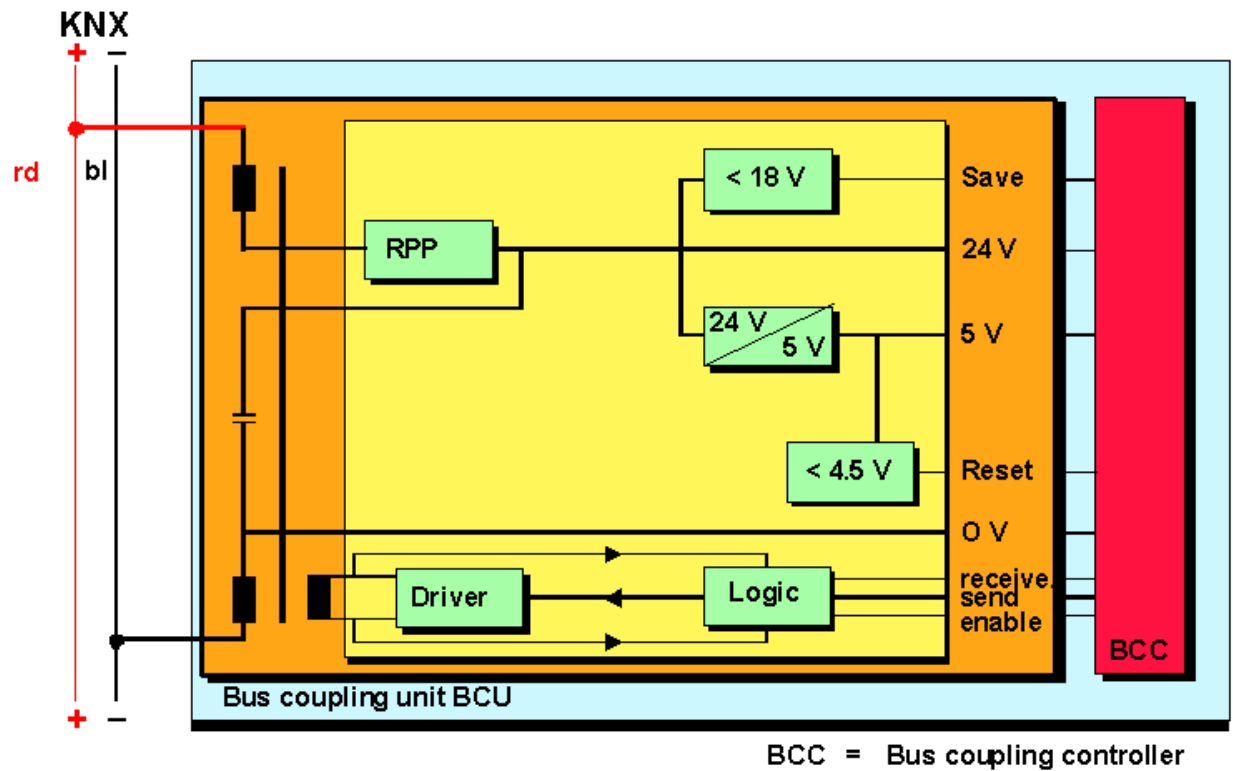

**Figure 3: TP1- Transceiver**

The TP1 transceiver has the following functions:

- ✚ Separation or superimposing of the direct current and data
- ✚ Reverse voltage protection (RPP)
- ✚ Generation of stabilised voltages of 5 respectively 24V
- ✚ Initiating a data back-up (Usave) if the bus voltage drops below 18V
- ✚ Triggering a processor reset if the voltage drops below 4.5 V
- ✚ Driver for transmitting and receiving
- ✚ Sending and receiving logic

### 3 Type Definition of an Application Module

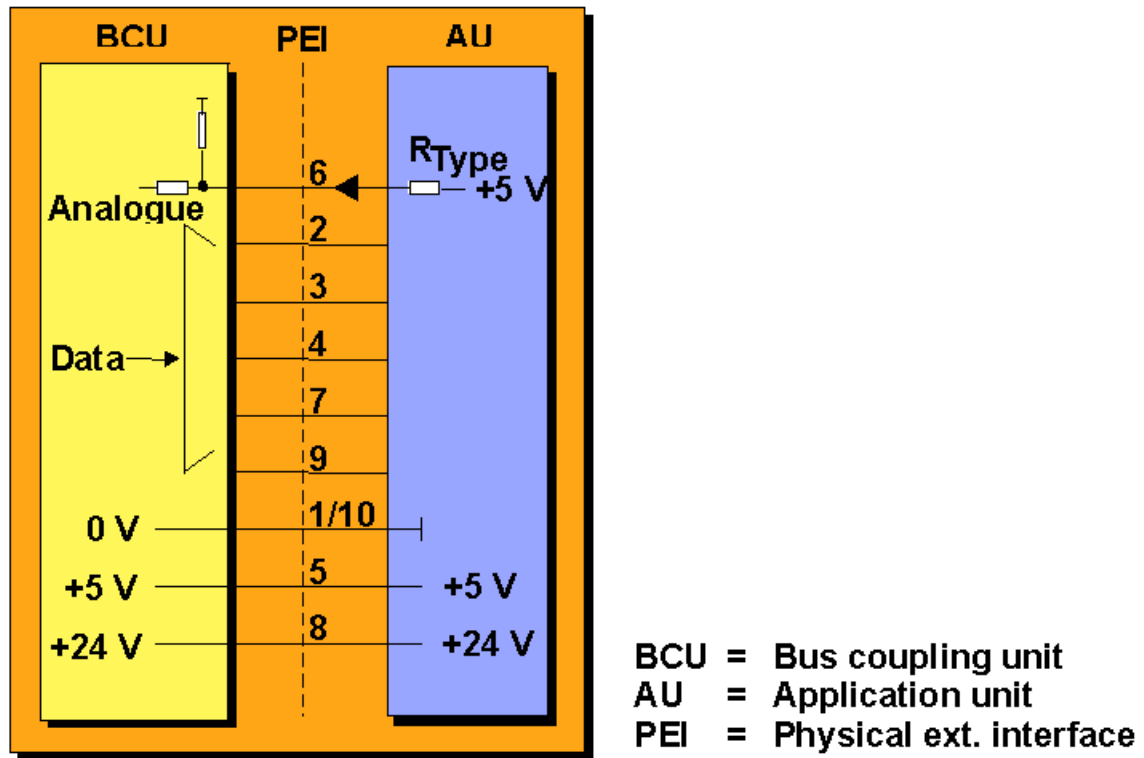

Figure 4: Type Definition of an application module

Via a resistor (R-Type) in the application module, the bus coupling unit is able to detect via pin 6 of the PEI, whether the application module mounted on the BCU fits to the loaded application program. When the R-Type does not correspond to the one indicated in the application program, the BCU automatically halts the application program. The table below gives an overview of the principal PEI types.

Type	Voltage V	Function
0	0.00	No application module connected
2	0.50	4 binary (analogue) inputs, 1 binary output
4	1.00	2 binary (analogue) inputs, 2+1 binary outputs
6	1.50	3 binary (analogue) inputs, 1+1 binary outputs
12	3.00	serial synchronous
14	3.50	serial synchronous fixed length
16	4.00	serial asynchronous
19	4.75	4+1 binary outputs
20	5.00	Download

## 4 Overview of principal KNX standardised system profiles

### 4.1 System 1 (TP1/PL110) – TP1 System 2 – TP1 System 7

System 1 technology is the first generation of KNX devices. Products based on System 1 and System 7, have also been available on the market for some time. The table below gives an overview of the principal characteristics of these KNX system components:

	<b>System 1 (TP1 + PL110)</b>	<b>System 2/7</b>
Maximum number of group objects	<b>12</b>	<b>255</b>
Maximum number of group addresses	<b>64</b>	<b>254</b>
Support of interface objects	<b>No</b>	<b>Yes</b>
Support serial number	<b>No</b>	<b>Yes</b>
Support access control	<b>No</b>	<b>Yes</b>

The System 7 technology is especially intended for more complex bus devices, which assume centralised functions (e.g. application controllers, gateways...).

Application programs designed for System 1 technology can also be loaded into a System 2.

## 4.2 System 2 and System 7 Characteristics

The characteristics of System 2 and System 7 outlined above are explained in detail below:

### 4.2.1 Access control

When a tool wants to access memory of System 2 and 7 devices (reading and/or writing), it must first get authorisation by means of an authorisation key of 4 Byte.

A manufacturer can define up to 16 such keys for a System 7 product or 4 keys for a System 2 product: however some of these are reserved for access to system relevant memory (amongst others the highest access key 0) and are therefore not communicated to the customers. The ETS (from version 1.1 onwards) is able to address these access mechanisms of the above mentioned device types.

Access control is never needed for normal communication via group addresses. In this case access is always possible.

### 4.2.2 Serial number

System 2 and System 7 devices use a serial number: this number, which is assigned to each device before leaving the factory, allows writing or reading the individual address of a device without having to press the programming button of the device. This feature is however not yet supported in ETS.

### 4.2.3 Interface Objects

Interface Objects contain certain system and application properties (e.g. address table, parameters ...), which can be read and/or written by a tool (e.g. ETS during download) without explicit knowledge of the device's memory map. The ETS end user cannot manipulate such objects.

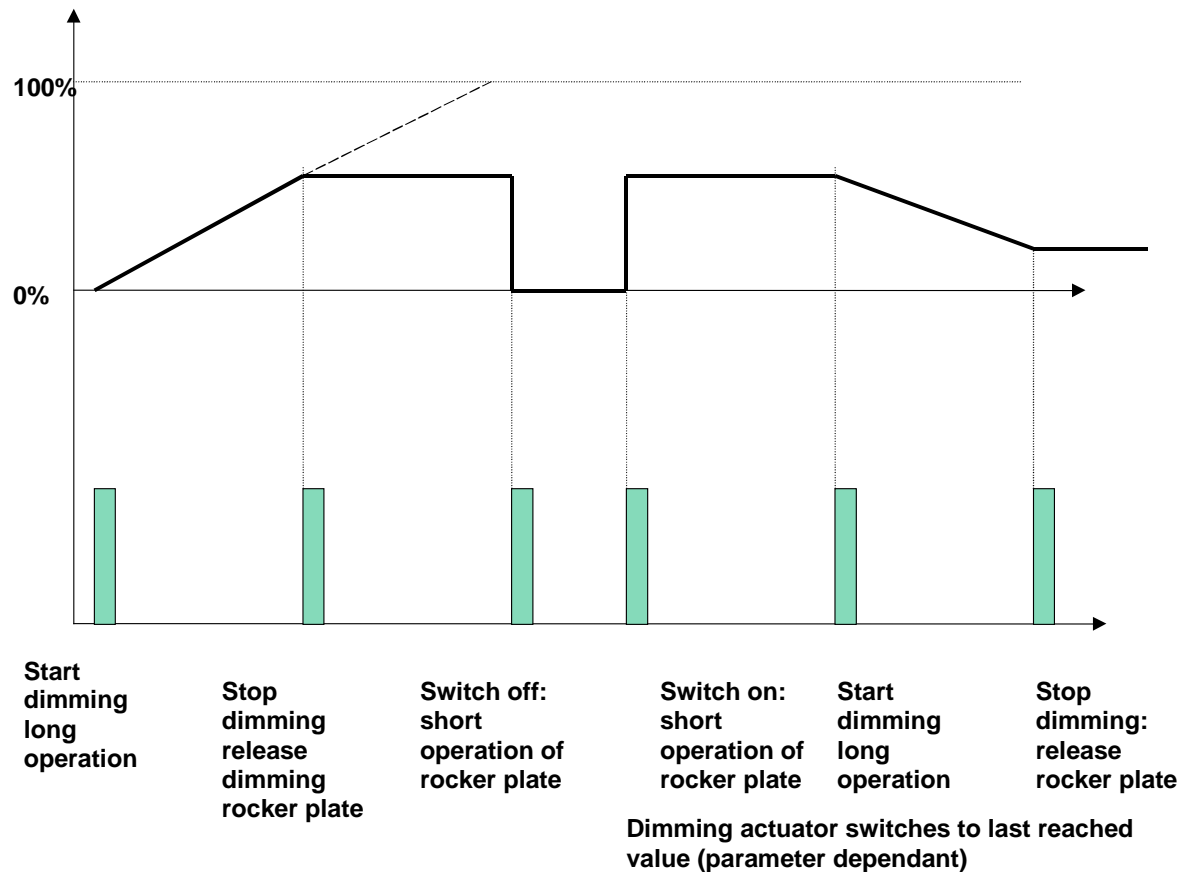

Figure 5: Dimming with Start/Stop Telegram

## 5 Application Function: Dimming with Start/Stop Telegram

The duration of the key operation determines whether the switching function or the dimming function is activated. If the time the key is pressed is shorter than  $t_2$  (e.g.  $< 500$  ms), a switch telegram is transmitted. Longer periods of key operation after the period  $t_2$  cause the transmission of a 'start dimming' telegram. As soon as the key is released again, a 'stop dimming' telegram is transmitted. The time  $t_1$  is used for key debouncing.

Different group addresses are used for the switching and dimming telegrams to ensure that the dimming actuator executes the correct functions.

Dimming speed of the actuator shall be adapted to the cyclical transmission of dimming telegrams

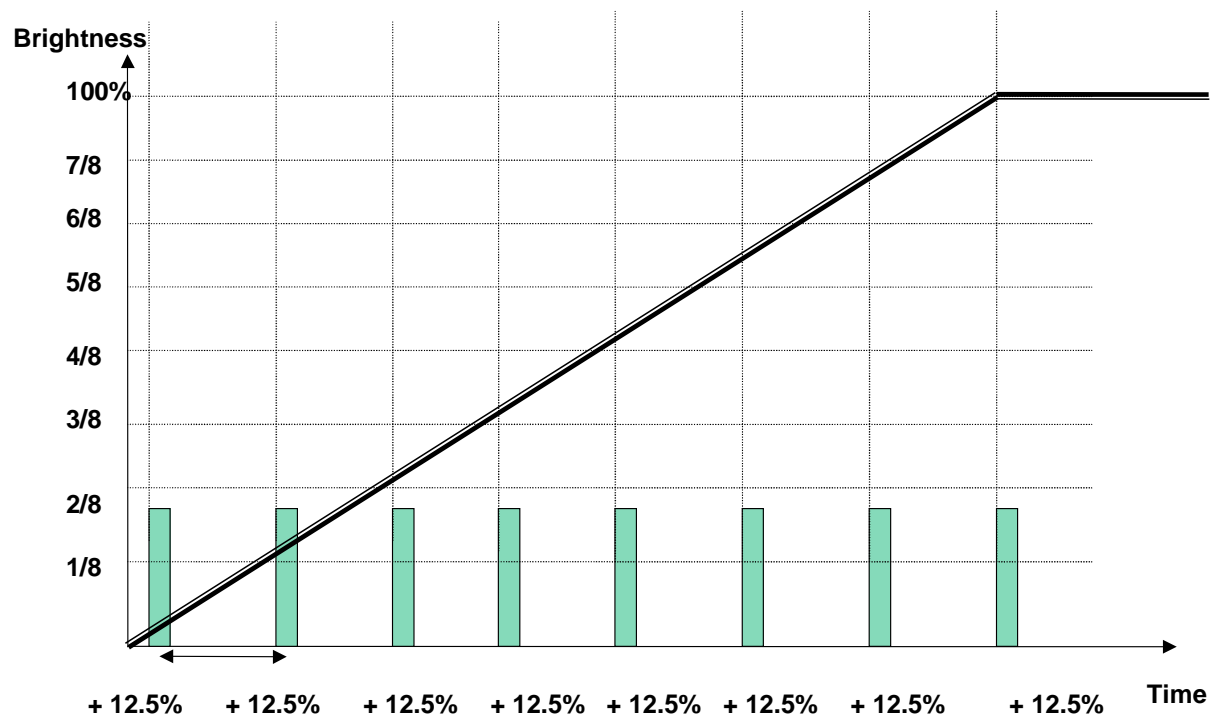

Figure 6: Dimming with Cyclical Telegrams

## 6 Dimming with Cyclical Telegrams

In a system controlled by infrared light, the light beam might be interrupted as somebody passes by. In order to avoid a situation where the dimming actuator does not receive telegrams (e.g. the stop telegram), in most cases one will choose the setting 'cyclical dimming' during parameterisation of an infrared control. The infrared sensor in these settings transmits the telegram 'increase brightness by 12.5%'. The consequences of losing such a telegram are not as serious as the loss of a stop telegram, which is only sent once.

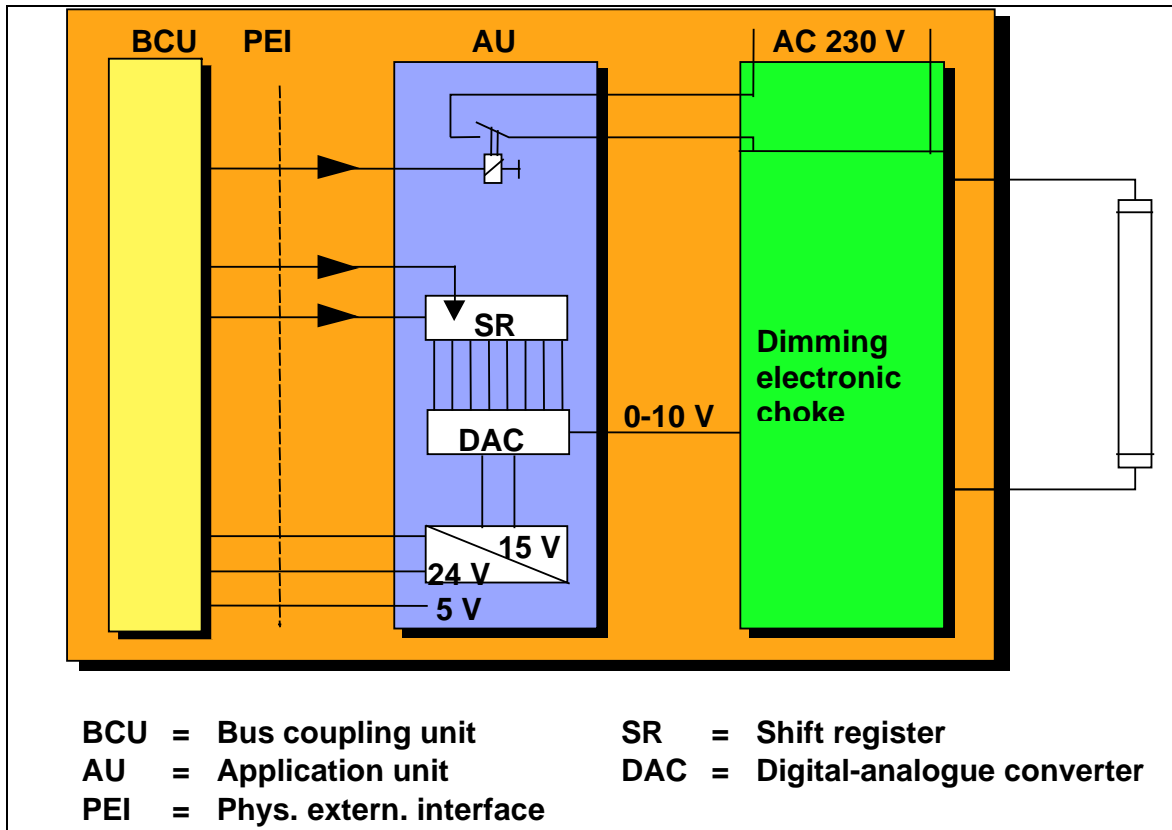

Figure 7: Application function: 'Dimming actuator'

## 7 Application Function: 'Dimming Actuator'

During the dimming period, the bus coupling unit increases or decreases the digital brightness value according to the set regulating time. The brightness value is continuously passed on to the shift register (SR) in the application unit.

The 8 bit long data word allows the generation of  $2^8 = 256$  brightness values.

The data word is fed into the digital/analogue converter (DAC), which then generates the appropriate control voltage in the range of 0 to 10V. The dimmer's electronic choke uses the voltage to control the light emission of a fluorescent tube. The power circuit breaker in the application unit is used to (dis)connect the mains voltage.

## 8 Application: Drive Control Sensor

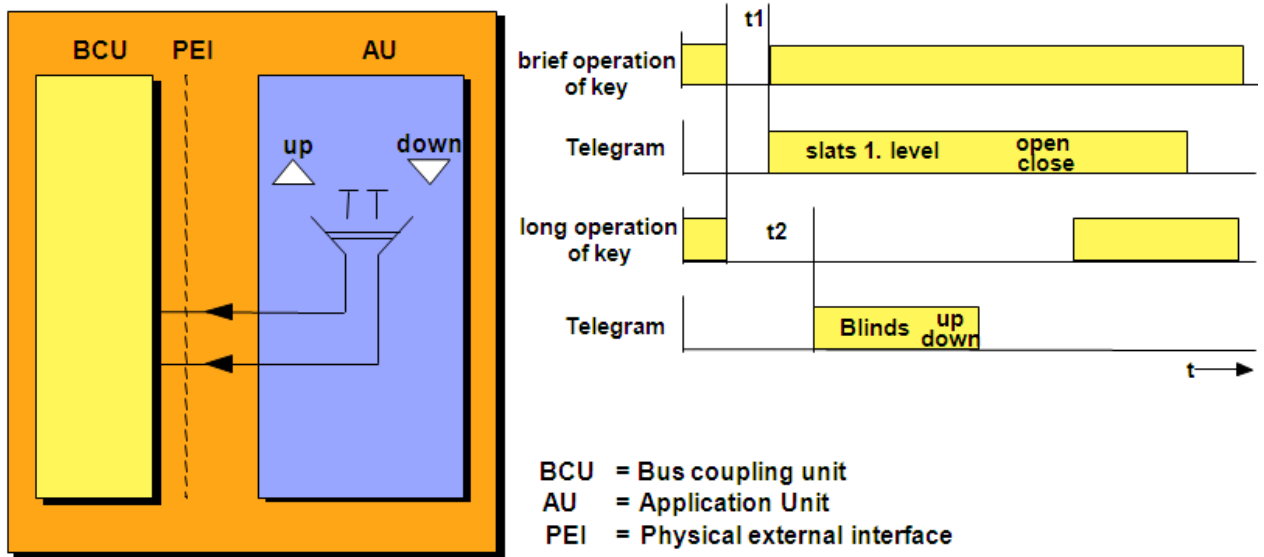

**Figure 8: Application: Drive Control Sensor**

The time  $t_2$  (e.g. 500 ms) acts as a "boundary" between the commands "slats open/close 1 step' and 'blinds up/down'.



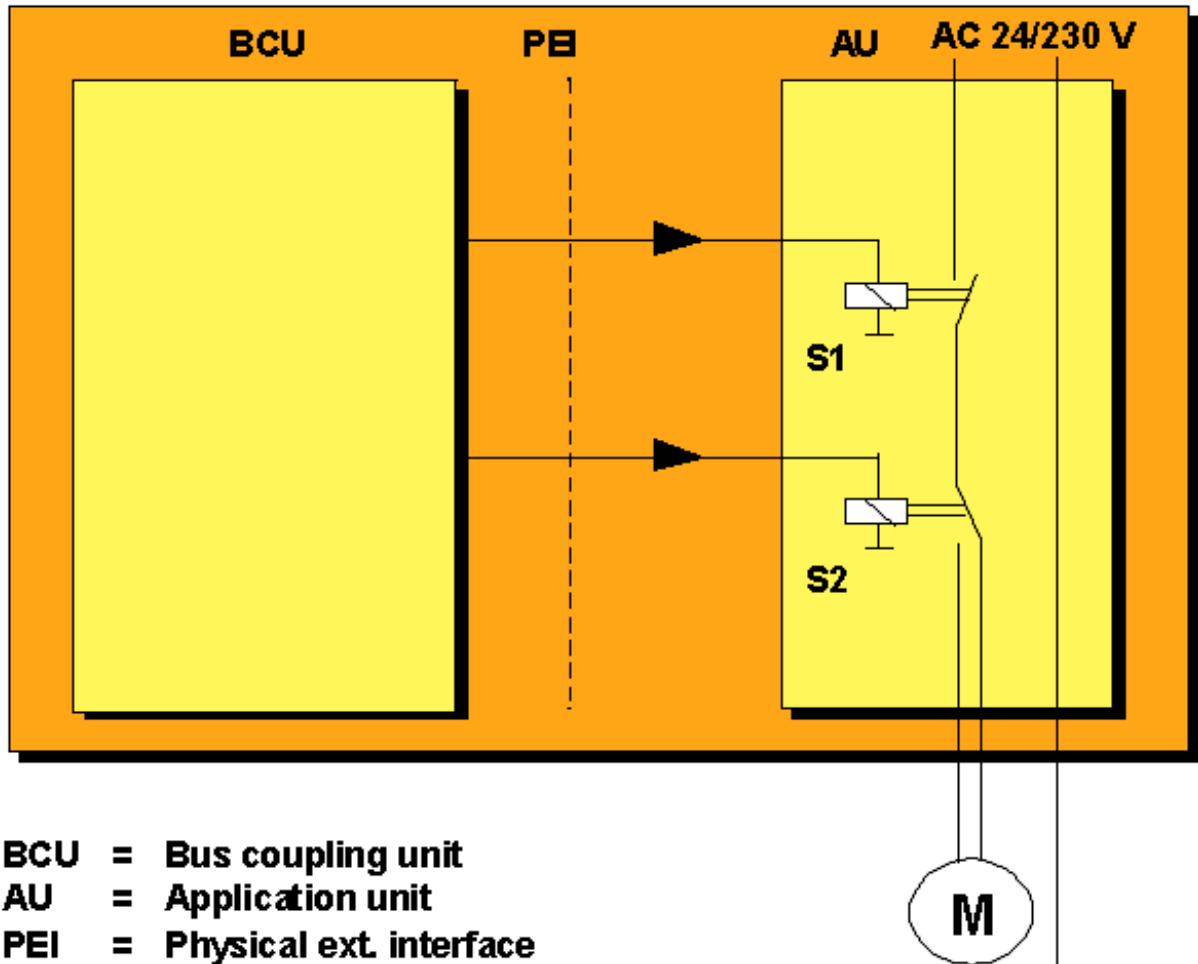

Figure 9: Application: Drive Control

## 9 Application: Drive Control

Depending on the telegram received, the BCU transmits the command 'up' or the command 'down' to the power circuit breaker S2. On receiving the telegrams 'slats open/close 1 step', the BCU energises the circuit breaker S1 for the appropriate duration. If the motor was already switched on, this telegram halts the blind. On receiving the telegram 'blinds up/down', the BCU energises the circuit breaker S1 for a period longer than the time the blind is in movement. As usual the limit switches bring the motor to a halt when one of the limit positions is reached.

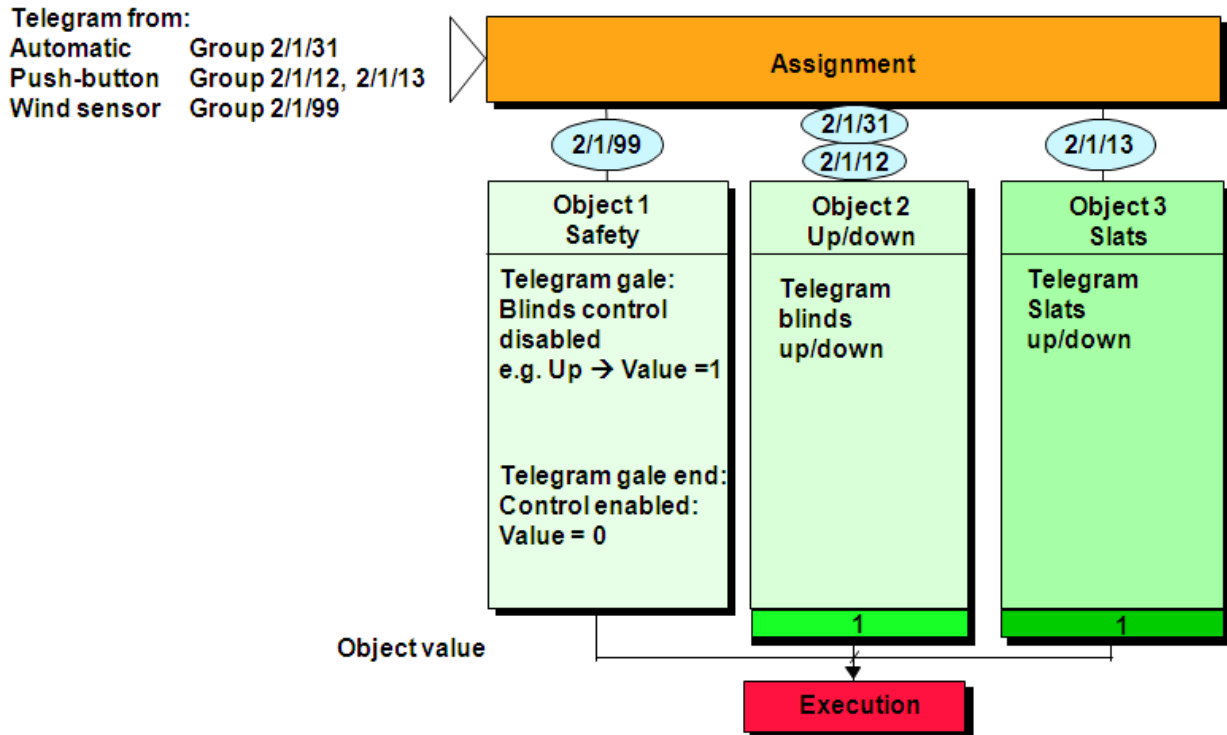

Figure 10: Drive Control Object Structure

## 10 Drive Control Object Structure

If, for example, the sensor responsible for measuring the position of the sun triggers the telegram 'blinds down' using the group address 2/31, the object group "up/down" is addressed and the corresponding command is executed.

Brief operation of the key sensor transmits the 2/13 telegram 'adjust slats' and long operation of the key sensor sends the 2/12 telegram 'open/close blinds completely'. Telegram 2/99 triggered by the wind sensor addresses the object group 'security'. If a gale is developing, telegram 2/99 orders the blinds to be opened completely and disables any further operation. When the storm has eased off, a telegram is sent that enables blind operation again.

# KNX TP1 Installation

KNX Association

## Table of Contents

1	Safety Low Voltage Networks .....	3
2	SELV Safety Extra Low Voltage Network .....	4
3	Types of Bus Cable.....	5
4	Installation of Cables.....	7
5	Bus Devices in Distribution Boards .....	8
6	Power Supply Unit.....	9
6.1	Power Supply for Two Lines .....	12
6.2	Two Power Supply Units on One Line .....	13
7	Distributed power supply .....	14
8	Data Rails and Data Rail Covers.....	15
9	Bus Cables in Wall Boxes .....	16
10	Installation of Flush-mounted Bus Devices.....	17
11	Standardised TP1 Bus Connection Block.....	18
12	Lightning Protection Measures.....	19
13	Bus Cables Installed between Buildings.....	21
14	The Prevention of Loops .....	22
15	Basic Immunity of Bus Devices .....	23
16	Bus Devices on Cable Ends.....	23
17	The Overvoltage Arrester Terminal .....	24
18	Recommendations to the use of overvoltage arresters .....	24
19	Checking the Installation .....	25

<b>SELV Safety Extra Low Voltage</b>				
<ul style="list-style-type: none"> <li>• Safety transformer</li> <li>• Voltage range less than/identical to 120 V<sub>~</sub> or 50 V<sub>~</sub></li> <li>• Safe isolation z.B. zu 230/400 V<sub>~</sub></li> <li>• SELV may not be earthed</li> </ul>	Relevant voltage	Mains type	Creepage Distance/clearance	Test voltage
	230/400 V <sub>~</sub> 400 V <sub>~</sub> 24 V <sub>~</sub> Ground	TN/TT  IT	5,5/5,5 mm 8,0/8,0 mm 1,25/0,8 mm 1,5/1,0 mm	4,0 kV <sub>~</sub> 6,0 kV <sub>~</sub> 0,6 kV <sub>~</sub> 1,0 kV <sub>~</sub>

Figure 1: Safety Low Voltage Networks

## 1 Safety Low Voltage Networks

*General: for the bus and mains installation the relevant installation requirements of the respective country shall be observed.*

SELV stands for Safety Extra Low Voltage

Clearance and creepage distances:

The clearance and creepage distances indicated above apply for:

- ✚ Pollution degree 2 (offices)
- ✚ Overvoltage category 3 (permanently connected to mains, high availability)
- ✚ Insulation material class 3

Permitted voltage range:

- ✚ Alternating current:  $\leq 50$  V
- ✚ Direct current:  $\leq 120$  V

No special protection against direct contact if required if the voltages do not exceed 25 V<sub>~</sub> or 60 V<sub>~</sub>.

Earthing:

- ✚ A SELV network must not be earthed!

## SELV Safety Extra Low Voltage

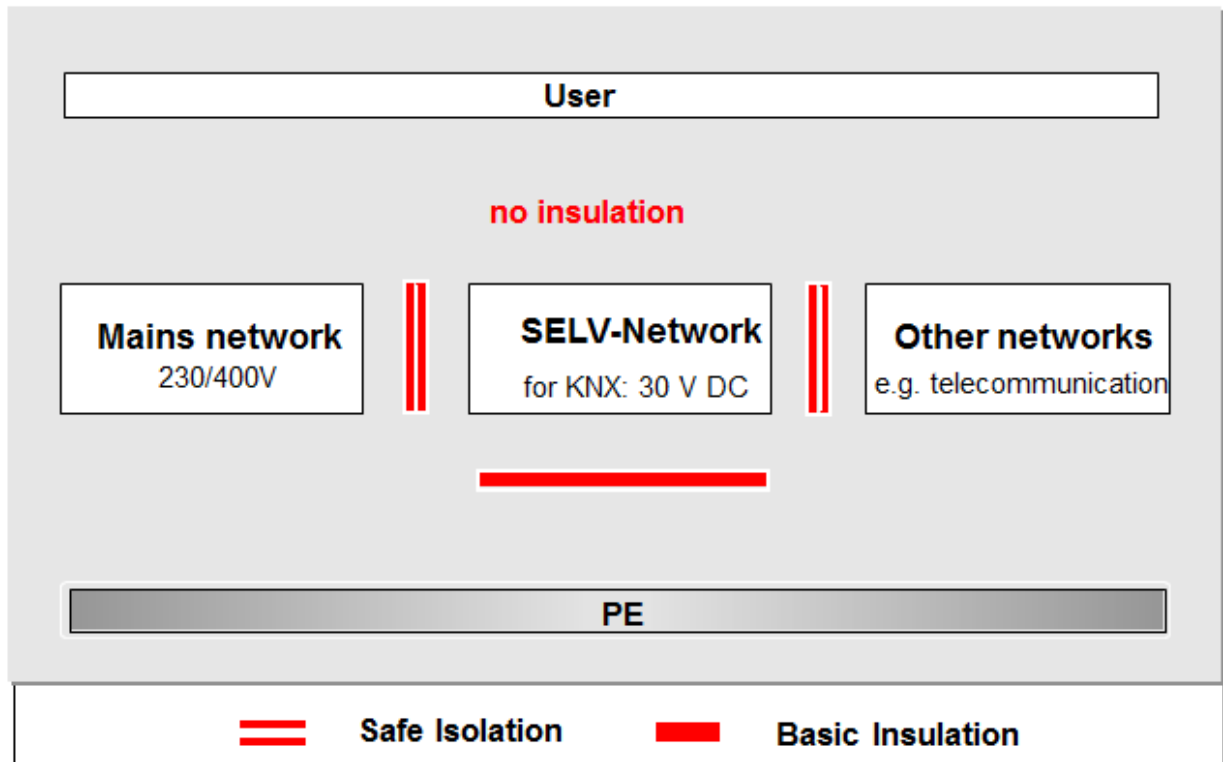

Figure 2: SELV Safety Extra Low Voltage Network

## 2 SELV Safety Extra Low Voltage Network

A safety transformer generates the SELV voltage for the KNX TP1 Installation Bus.  
Voltage used:

✚ DC 30 V

Insulation:

- ✚ Safe isolation from other networks.
- ✚ Basic insulation to earth.
- ✚ No insulation on the user's side.

### Attention:

- ✚ The SELV network must NOT be earthed!
- ✚ Cables that are intended for the installation of heavy-current networks may not be used for the installation of TP1 networks!

### YCYM 2×2×0.8

**Fixed installation:**  
dry, humid and wet rooms; wall-mounted, flush-mounted, in conduits; outdoor (if protected against direct sun radiation);

**Test voltage: 4 kV according to EN 50090**

### J-Y (St) Y 2×2×0.8 VDE 0815

**Fixed installation:**  
dry and humid industrial sites: wall-mounted, flush-mounted and in conduits  
**Outdoor: flush-mounted and conduits**

**Test voltage: 2,5 kV according to EN 50090**

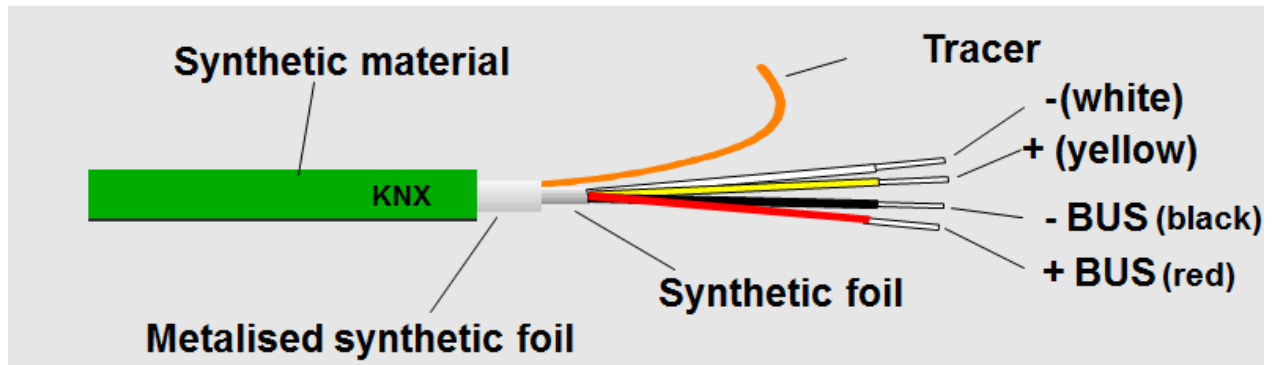

Figure 3: Types of bus cable

## 3 Types of Bus Cable

Twisted Pair 1 cable which fulfils the KNX requirements in volume 9 of the KNX Specifications (e.g. YCYM 2×2×0.8 or J-Y(St)Y 2×2×0.8 in TP1 design) can be recognised (without KNX logo) or certified (with KNX logo) by KNX Association<sup>1</sup>. Only the standard green KNX TP1 cable guarantees:

- ✚ max. cable length of a line
- ✚ max. distance between two bus devices on a line
- ✚ max. number of bus devices per line



This is based on the loop resistance of 75 Ω and the loop capacitance of 100 nF per 1000 m. For all other cables, the maximum length given in the data sheet of the cable must be observed.

It is not normally necessary to connect the shielding of the installed cable types.



<sup>1</sup> For the current list of KNX certified/approved cable types, please consult the KNX web site ([www.knx.org](http://www.knx.org))

When installing a standard cable with a test voltage of 4 kV, the following conditions apply.

Used wire pair:

-  Red: plus
-  Black: minus

Spare wire pair: Permitted use of the spare wire pair:

-  no connection at all
-  for other SELV low voltage methods

Test voltage according to EN 50090:

The specified test voltage must be applied to all connected wire cores (shielding drain wire included) and the outer surface of the cable sheath.

**Note:**

Please make sure that the cables are properly identified and marked!



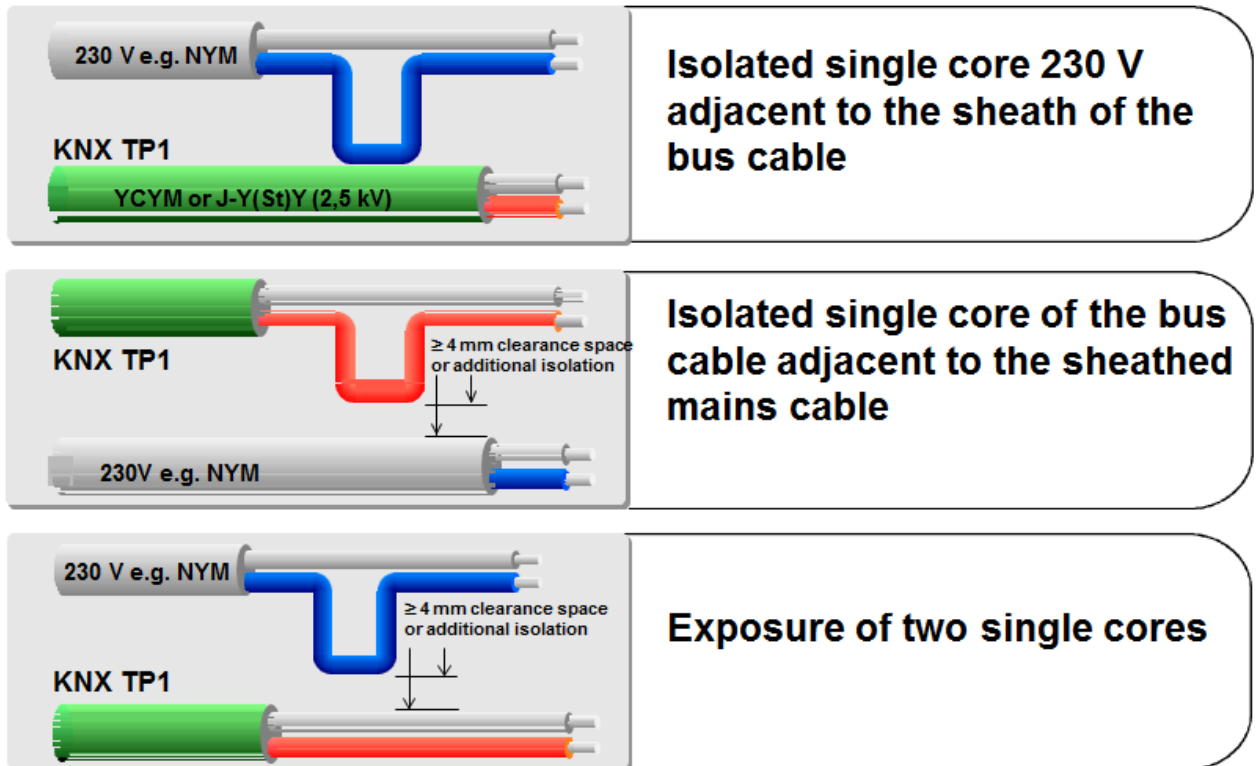

Figure 4: Installation of cables

## 4 Installation of Cables

The requirements for the installation of bus cables are generally the same as for the installation of 230/400 V networks.

Special requirements:

- ✚ Insulated wire cores of sheathed mains cables and KNX TP1 bus cables may be installed next to each other without any clearance space.
- ✚ A minimum clearance space of 4 mm must be observed between the insulated wire cores of KNX TP1 bus cables and those of sheathed mains cables. Alternatively, the wire cores must be provided with an equivalent insulation, such as a spacer or insulation sleeving (DIN VDE 0110-1, Basic insulation). This also applies to wire cores of other cables that are not part of SELV/PELV circuits.
- ✚ An adequate distance to the external lightning protection system (lightning arrester) must be ensured.
- ✚ All cables should be permanently marked as **KNX TP1** or **BUS** cables.

A terminating resistor is not required.

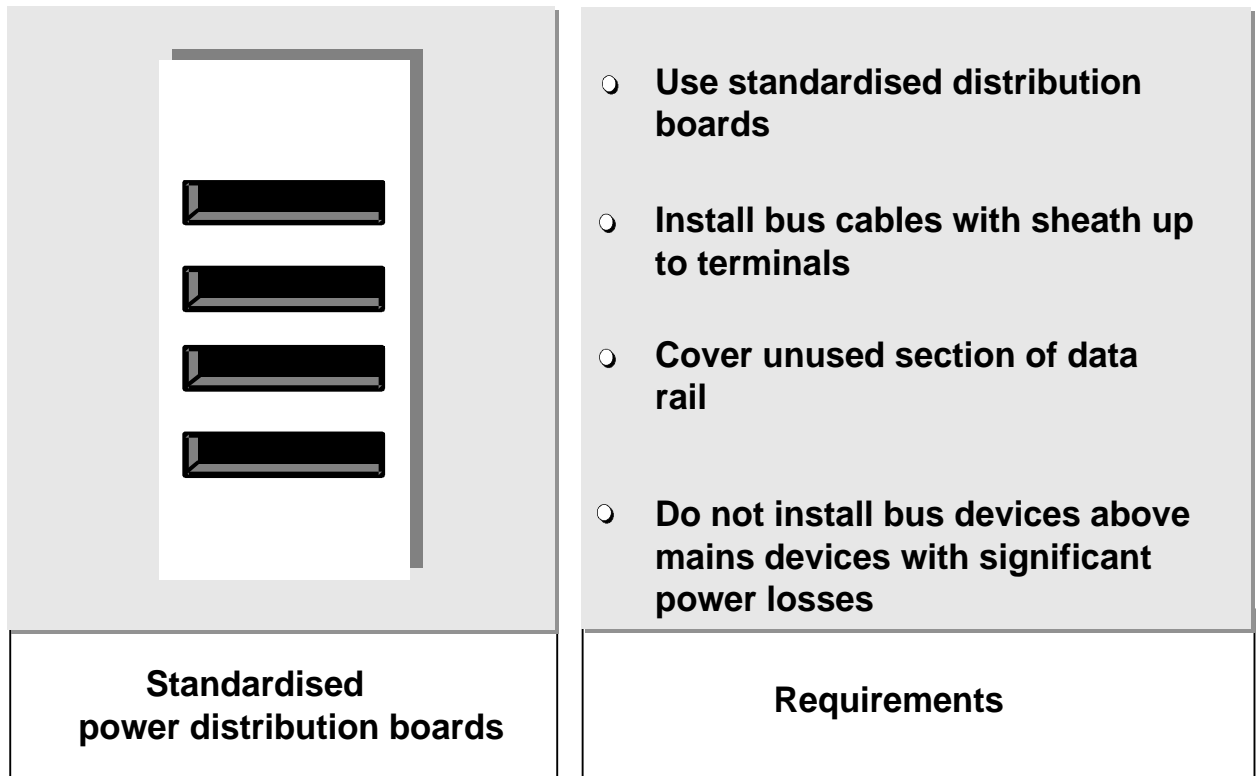

Figure 5: Bus devices in distribution boards

## 5 Bus Devices in Distribution Boards

Any commercial, standardised electric power distribution boards equipped with EN 50022 35x7.5mm DIN rails may be used, on which KNX TP1 DIN rail mounted devices can be installed. Some of these KNX TP1 DIN-rail mounted devices use spring contact blocks to a standard data rail glued into DIN rails, others provide the normal bus connector (see later) for connection to the bus.

Unused parts of data rail must be protected by cover strips.

If the mains section is separated from the installation bus, no special installation requirements need to be observed.

If the mains section is not separated from the installation bus, the bus cables must be sheathed up to the terminals.

Possible contact between mains cores and bus cable cores must be prevented by adequate wiring and/or mounting.

Bus devices should not be mounted above mains devices with significant power losses, as this could cause excessive heat development in the installation.

When a lightning arrester is installed on a DIN rail containing a data rail, the following requirements must be met:

- ✚ Overall insulation of the arrester (e.g. do not use any uncovered air sparking gaps).
- ✚ As DIN rails may not be used for earthing, arresters must be provided with a separate earthing terminal.

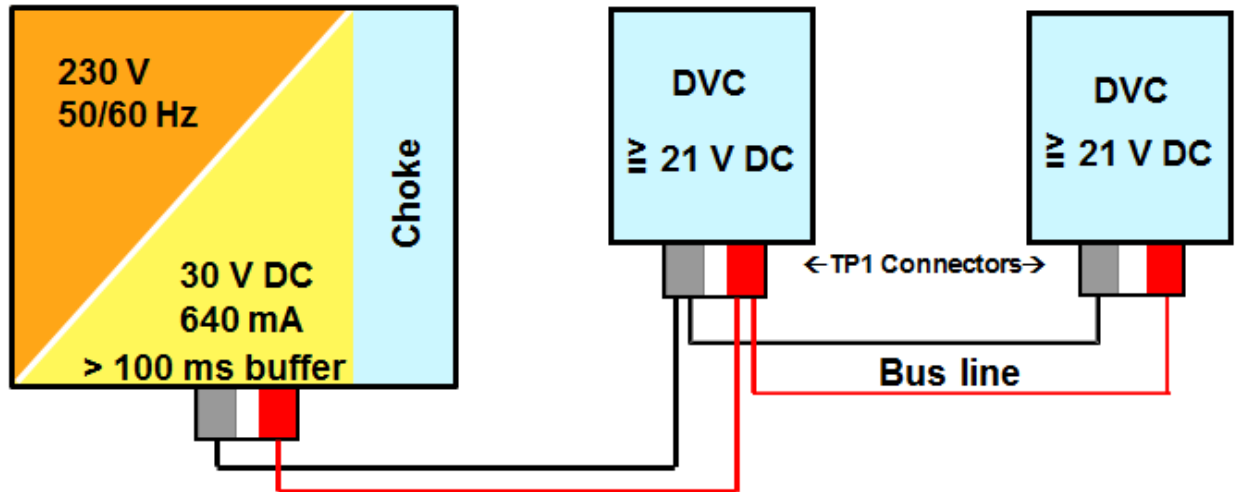

Figure 6: Power supply unit (with TP1 connectors)

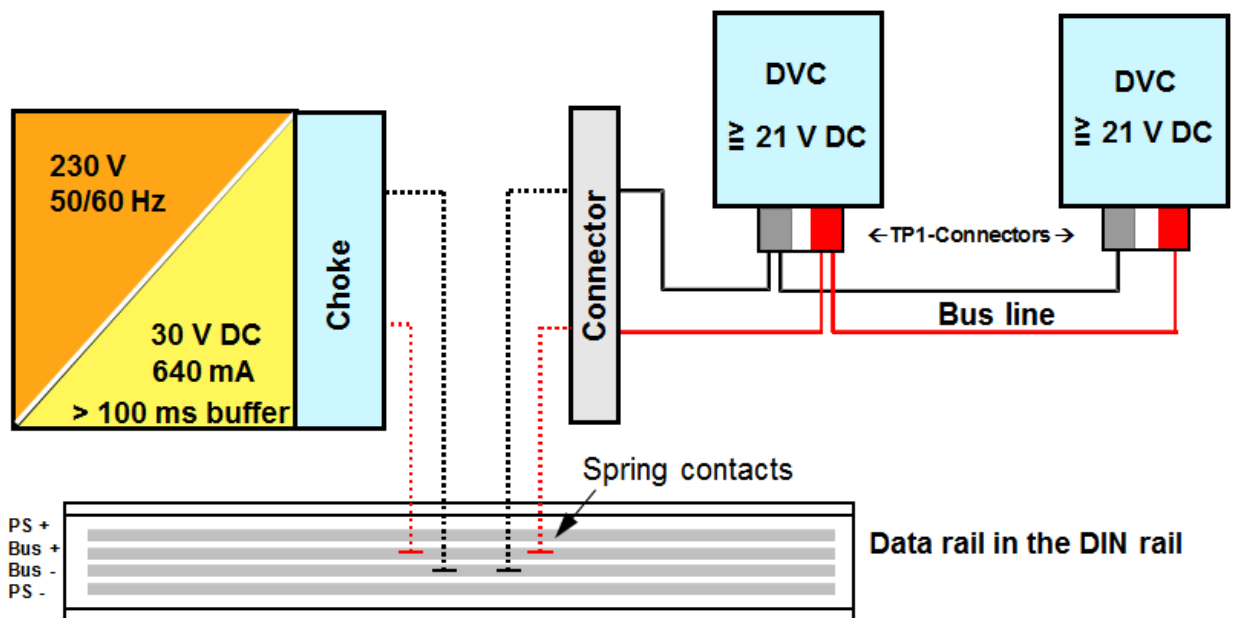

Figure 7: Power supply unit (DIN Rail with data rail)

## 6 Power Supply Unit

**Note:** if not explicitly said underneath, the underneath clauses deal with the centralised power supply units.

Power supply units produce and monitor the system voltage of 30 V that is necessary for the operation of a KNX TP1 installation. Each line has its own power supply unit for the bus devices. The power supply unit has an integrated voltage and current control and is therefore resistant to short circuits.

A buffer with a stored-energy time of 100 ms is able to bridge short power gaps.

Bus devices require a minimum of 21 V for safe operation and constitute a load of up to 200 mW on the bus except some devices whose energy requirement should be taken from the data sheet of the respective manufacturer (e.g. heating valves).

With a power supply of e.g. 640 mA, it is possible to connect 64 devices with a maximum capacity of 200 mW and an almost identical distribution on the line.

	<ul style="list-style-type: none"> <li>• <b>Prevention of static discharge as a result of earth connection</b></li> <li>• <b>100 ms buffer time bridges brief interruptions of the mains</b></li> <li>• <b>optional LEDs for displaying</b> <ul style="list-style-type: none"> <li>○ overload</li> <li>○ operation</li> <li>○ overvoltage</li> </ul> </li> <li>• <b>Additional output for supply another line (needs extra choke!)</b></li> </ul>
<p style="text-align: center;"><b>Example of one power supply unit</b></p>	<p style="text-align: center;"><b>Features</b></p>

Figure 8: Example and features of a power supply unit (on DIN-Rail without data rail)

	<ul style="list-style-type: none"> <li>• <b>Prevention of static discharge as a result of earth connection</b></li> <li>• <b>100 ms buffer time bridges brief interruptions of the mains</b></li> <li>• <b>optional LEDs for displaying</b> <ul style="list-style-type: none"> <li>•overload</li> <li>•operation</li> <li>•overvoltage</li> </ul> </li> <li>• <b>line supply normally <u>via data rail</u></b></li> <li>• <b>additional output for supply another line (needs extra choke)</b></li> </ul>
<p style="text-align: center;"><b>Example of one power supply unit</b></p>	<p style="text-align: center;"><b>Features</b></p>

Figure 9: Example and features of a power supply unit (on DIN-Rail with data rail)

To prevent static charges on the bus side, the power supply unit has high ohmic resistances connected from each bus core to earth.

The power supply unit should be earthed. To do so, connect the earth point of the low voltage section to the power supply unit. This connection should be marked yellow/green. It does not have any protective effect according to safety regulations and does not contradict the conditions that apply to SELV networks.

Some power supply types or the external chokes have a reset switch and a red control LED. The connected line can be set to 0 V with this switch.

The chokes prevent the short-circuiting of bus telegrams (alternating voltage 9600 Hz) via the filter or charging capacitor of the power supply unit.

Many types of power supply units are available, depending on the supplied output current (160 mA, 320 mA, 640 mA)). It goes without saying that the number of installable devices in a line depends on type of PSU used and the individual power consumption of the devices in that line. Some PSU types have an integrated choke, some need an additional external choke.



Most of the power supply units are DIN-rail mounted types, whereby only the two outer printed conductors of the data rail make contact with the power supply unit.

Some types have an additional output, with which it is possible to supply other lines using an external choke.

Uninterruptible power supply types are also available.

Some PSU types have a floating relay output providing information about normal operation/mains failure for evaluation purposes.

Most of the PSU types have LEDs, indicating the operating mode of the power supply unit e.g.

-  Green: The power supply is active.
-  Red: The power supply unit is overloaded, maybe due to a short circuit between bus wires.
-  Yellow: An external voltage higher than 30 V has been applied to the bus side.

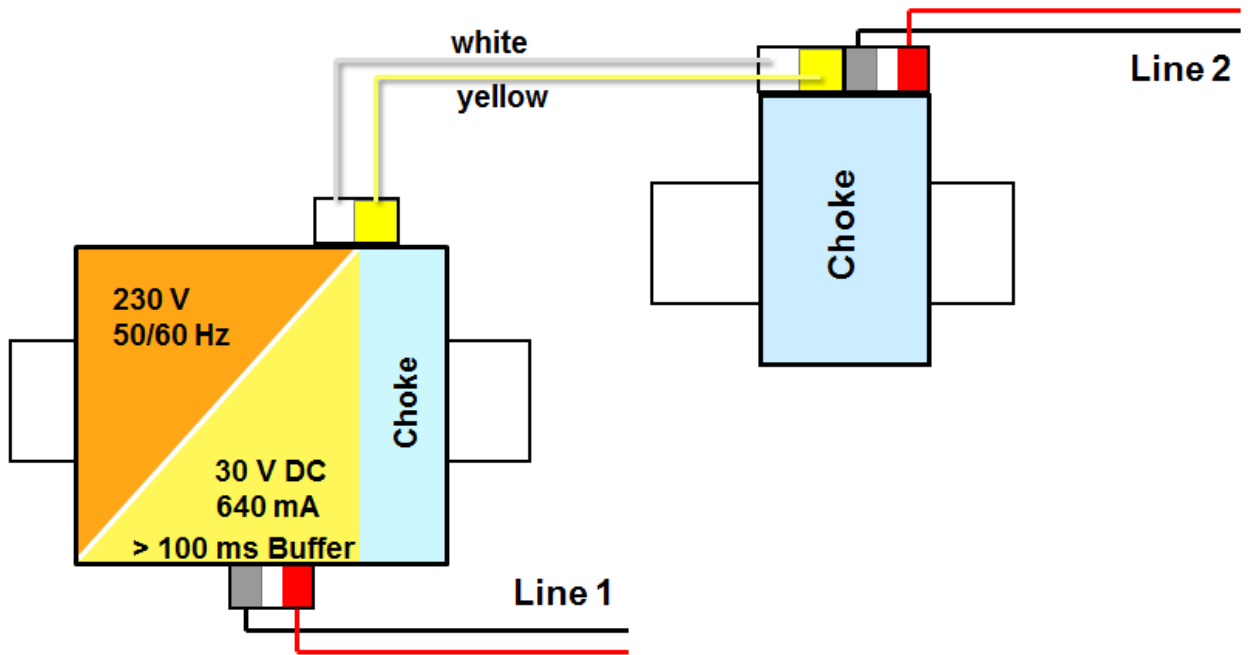

Figure 10: Power supply for two lines (DIN-Rail without data rail)

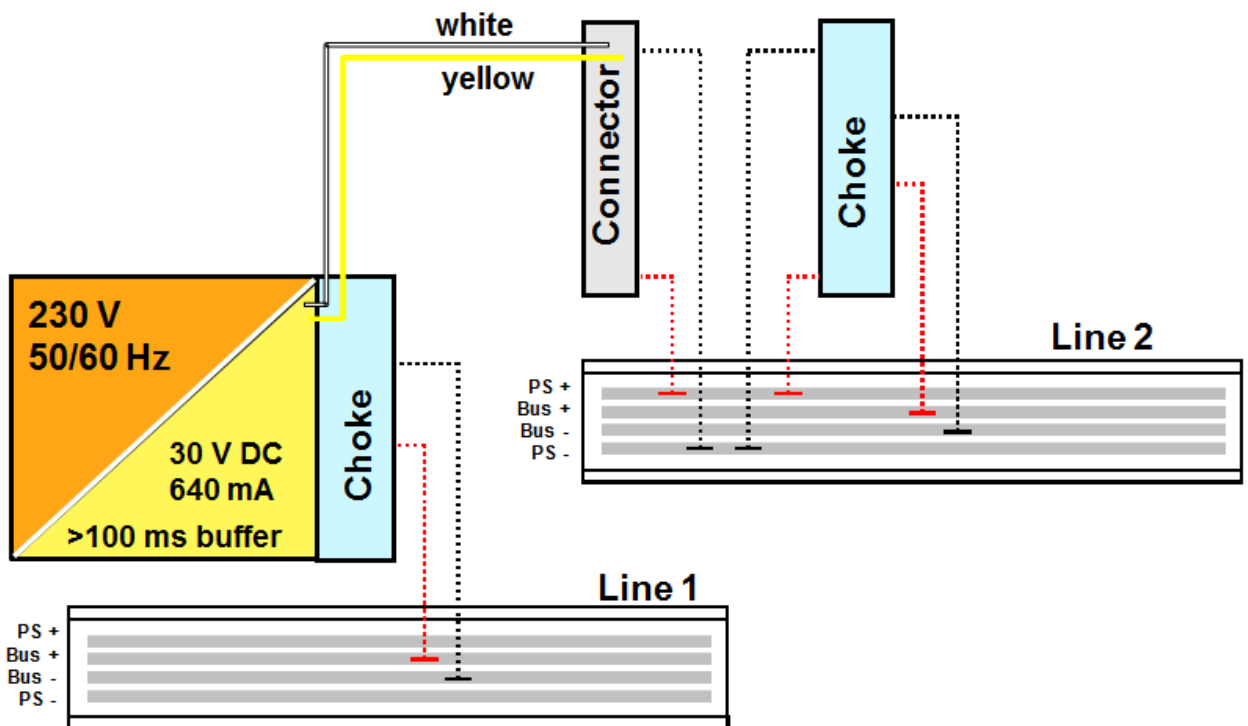

Figure 11: Power supply for two lines (DIN-Rail with data rail)

## 6.1 Power Supply for Two Lines

If additional current is needed, one power supply unit for two lines can be implemented. An additional choke may be required depending on the type of power supply unit.

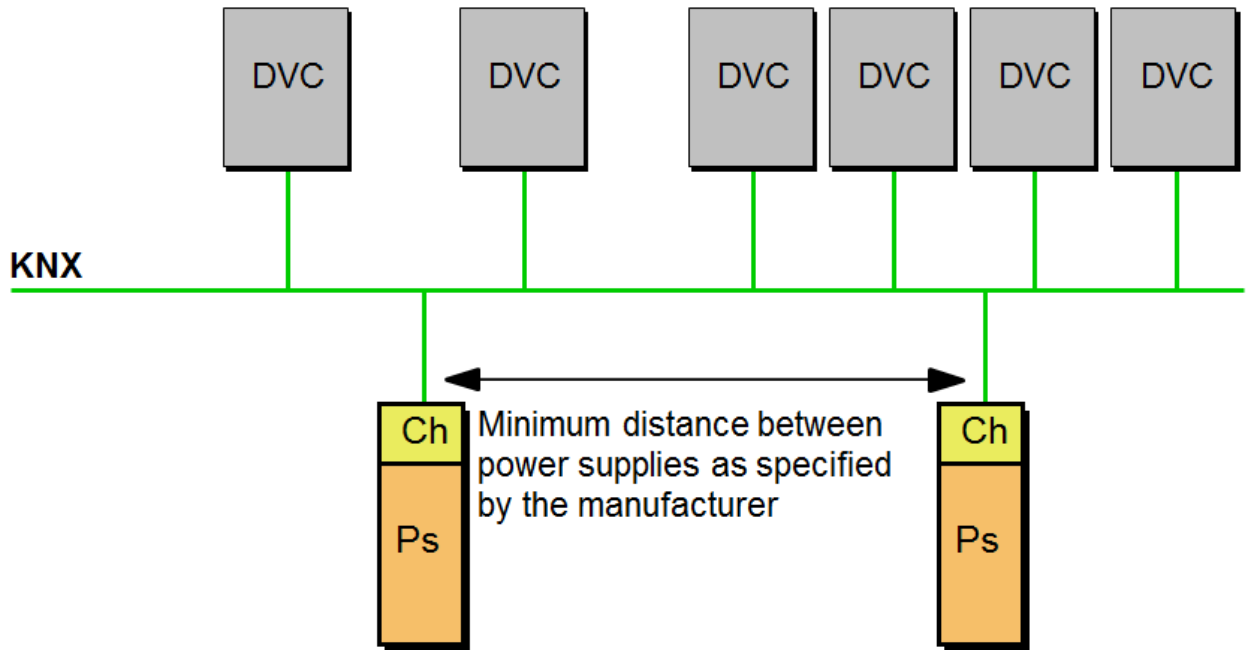

Figure 12: Two power supply units on one line

### 6.2 Two Power Supply Units on One Line

If more than 30 bus devices are connected within a short distance to each other (e.g. on a distribution board), the power supply unit should be installed in the vicinity of this group.

If an additional power supply unit is to be installed, the minimum distance shall be taken from the product specifications. One line may only have a maximum of two power supply units connected to it.

Cable length	Type of bus power supply			
	Decentralised bus power supply with number of powering devices with DPSU			Central bus power supply (PSU)
	1	2	3 ... 8	
Max. total cable length	350 m	700 m	1000 m	1000 m
Max. distance between communicating devices	350 m	700 m	700 m	700 m
Max. distance of non-powering device from power supply	350 m	350 m	350 m	350 m
Min. distance of 2 bus power supplies	No minimal cable distance between two DPSU or between DPSU and standard central PSU			As specified by the manufacturer

Figure 13: Cable length

## 7 Distributed power supply

Instead of a centralised bus power supply, the bus is powered in a distributed way by some devices connected to the line containing each a Decentralised Power Supply Unit (DPSU) with integrated choke module. Stand-alone DPSU (non-communicating devices) are also possible.

A DPSU is especially intended for small installations with few devices.

Different types of DPSU exist, depending on the supply current (25, 40 and 80 mA).

In most cases, it is possible to combine DPSU with up to two standard central PSUs. The DPSU can be located at any point in the bus line. There are no limitations concerning minimal distances between two DPSUs or DPSU and standard central PSU.

Up to eight DPSUs can be mounted in one single bus line. More than eight can have a negative effect on the communication. In case of mounting up to 8 DPSUs in a single line together with a central PSU, the maximum resulting short circuit current of these devices (as given in the product data sheet and/or ETS database) shall not exceed 3A.

In most cases it is possible to manually disable the DPSU on the device (e.g. by jumper or configuration of a parameter).

The to be observed cable length in conjunction with the use of central and decentralised power supply units is given in the above figure.



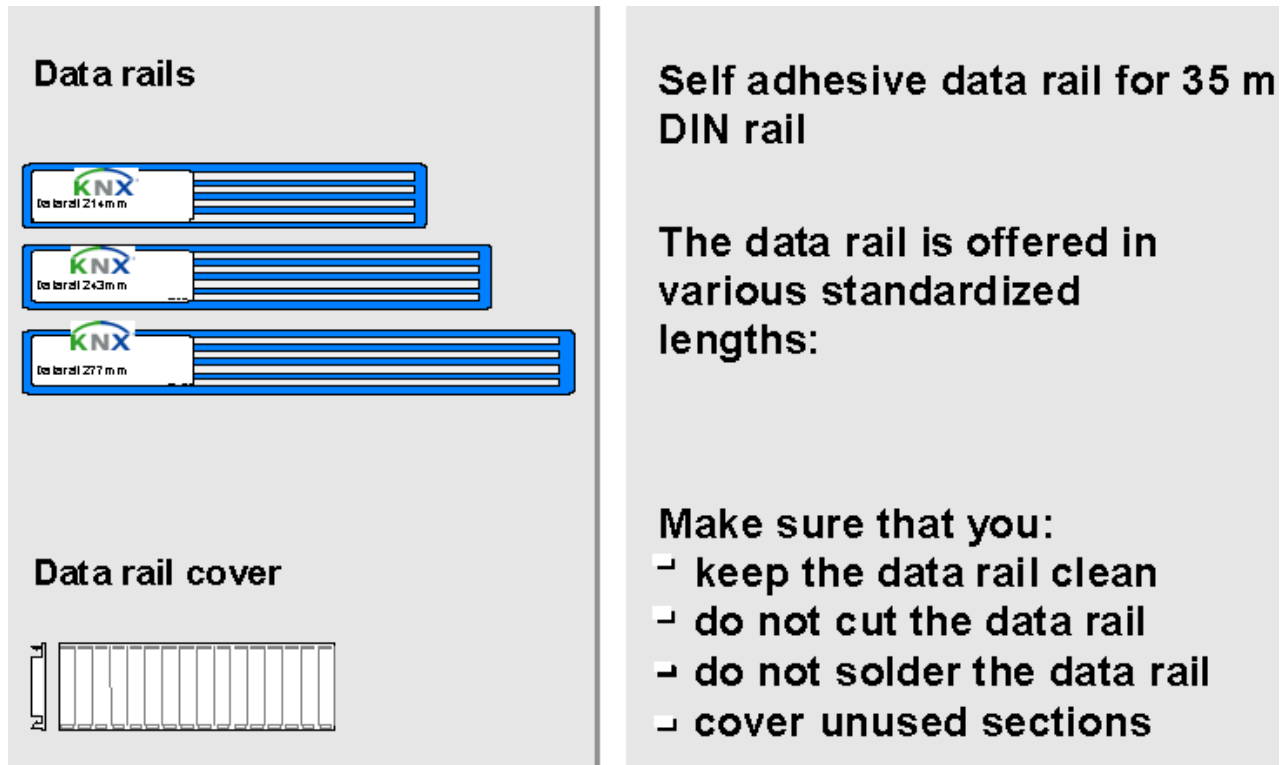

Figure 14: Data rails and data rail covers

## 8 Data Rails and Data Rail Covers

Some DIN rail type bus devices, such as binary outputs, dimmers, power supply unit etc., use a data rail to connect to the KNX TP1 bus.

The self-adhesive data rail is mounted on the 35 mm DIN rail according to EN 50022.

The lengths of ready-made data rails match the various widths of the standardised electric power distribution boards available. The length of a data rail may not be changed, for instance by cutting it shorter, as this would change the creepage and clearance distances.

When DIN-rail mounted KNX TP1 bus devices use the data rail to connect to the TP1 bus when snapped on the DIN rail, they do so by means of a pressure contact mechanism. In order to protect unused sections of data rail from pollution or from accidental contact with mains cables, they should be covered by a data rail cover.

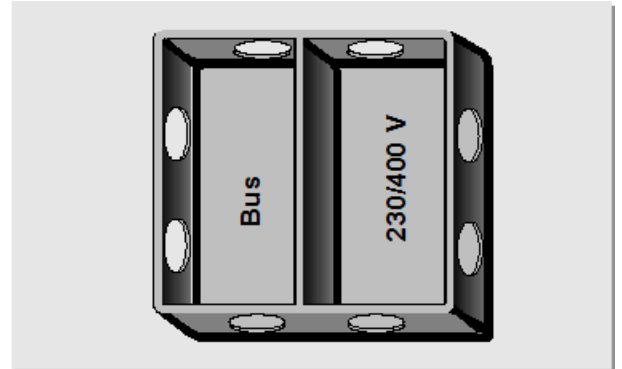
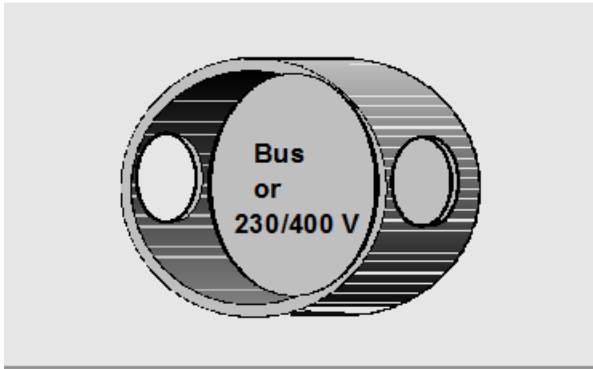

**Mains und bus wires should be installed either in**

- **Separate installation/wall junction boxes**
- **Common installation boxes with a partition, guaranteeing the required clearance/creepage distances**

Figure 15: Bus cables in wall boxes

## 9 Bus Cables in Wall Boxes

SELV circuits require double or reinforced insulation (protective separation) between mains and bus cables, i.e. unsheathed bus cable cores should never be in contact with mains cables.

Junctions can be installed:

- ✚ in separate boxes or
- ✚ in a common box with a partition, ensuring 8 mm clearance and creepage distances e.g. for TN/TT networks in office buildings.

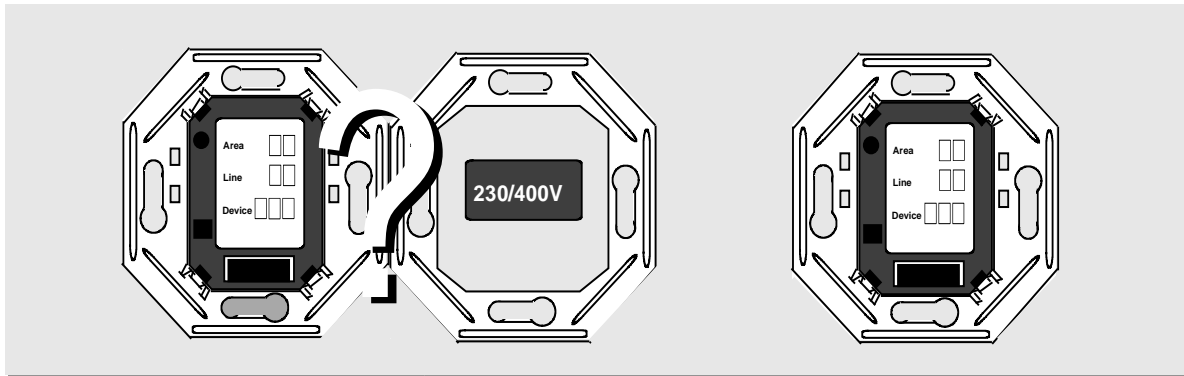

- **Use of wall boxes for screw mounting**
- **Permitted use of flush-mounted devices in combination with mains devices depends on the environmental conditions and the design of the bus devices (e.g. pollution degree, overvoltage category).**

**Figure 16: Installation of flush-mounted bus devices**

## 10 Installation of Flush-mounted Bus Devices

Only wall boxes suitable for screw mounting may be used. Clamp mounting is not possible in most cases.

In order to provide sufficient room for cables, wall boxes with a depth of 50 mm, for instance, should be installed.

‘Combinations’ refer to the use of mains devices (e.g. socket outlets) and bus devices (e.g. pushbuttons) or other electric circuits underneath a common cover.

Both components must be safely isolated from each other. This can be achieved by using basic insulation for the power devices and basic 230 V insulation for the bus device.

Please do not forget to enquire with the manufacturer of the bus device whether this particular device may be installed together with power devices.

Please note:

- ✚ The installation of a bus device in combination with power devices must be explicitly approved by the manufacturer of the bus device!
- ✚ The manufacturer may specify certain bus installation requirements, which must be strictly observed (e.g. connection of the frame to the protective earth conductor).
- ✚ Mains devices must at all times be protected against accidental contact, even when the common box cover is removed.

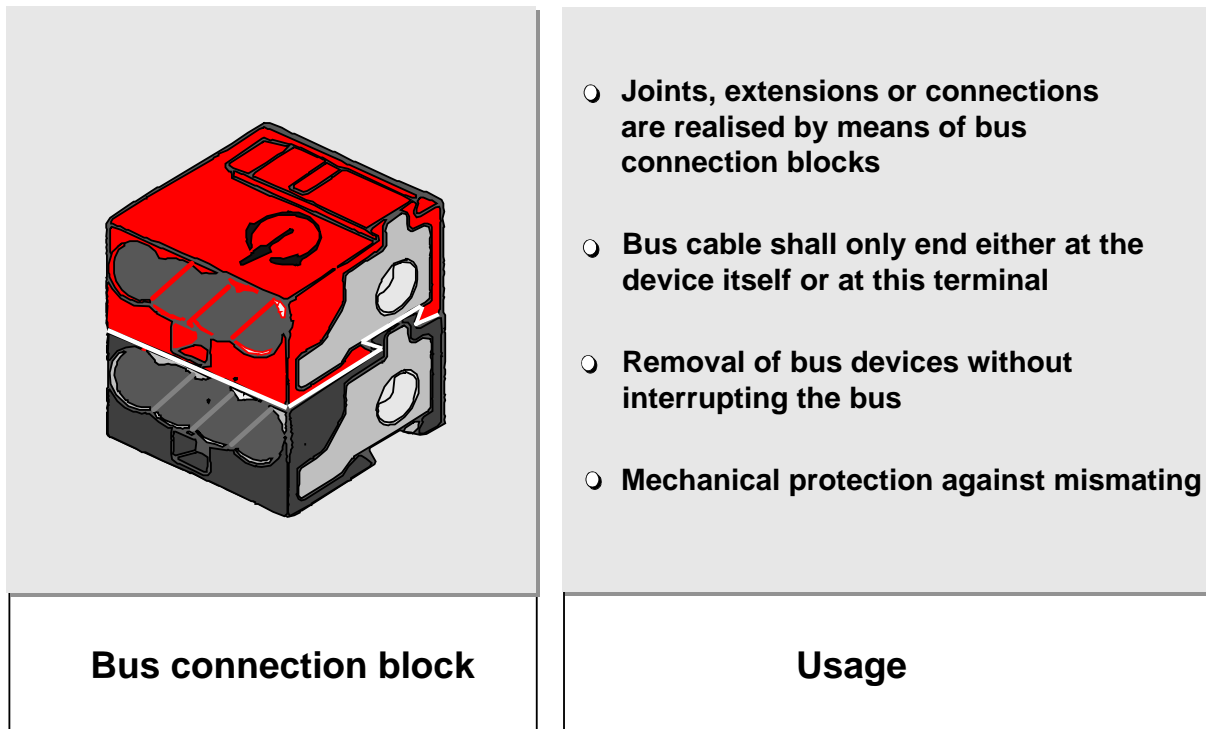

Figure 17: Bus connection block

## 11 Standardised TP1 Bus Connection Block

The bus connection block is used for

- ✚ branching the bus cable
- ✚ extending the bus cable
- ✚ protecting the bus cable ends
- ✚ connecting the bus cable to bus devices

To avoid confusion with other electrical circuits, the bus connection block should only be used for the KNX TP1 installation bus.

The bus connection block consists of two parts:

- ✚ the PLUS part (red) and
- ✚ the MINUS part (grey)

which are mechanically linked by means of a dovetail joint. Up to four bus wires (6 mm stripped) can be connected to each part by means of screwless terminals.

Standardised TP1 bus connection blocks allow the removal of bus devices without interrupting the bus wire.

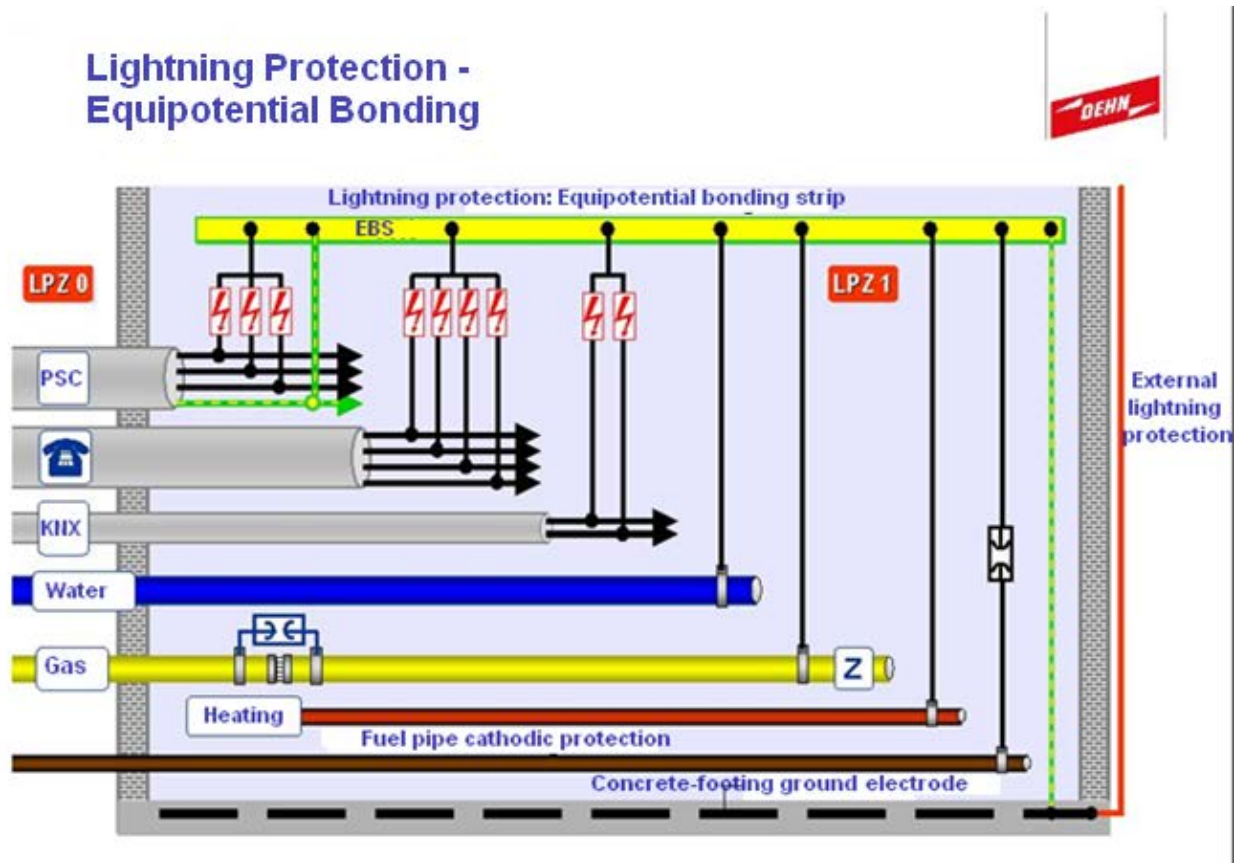

Figure 18: Lightning protection measures

## 12 Lightning Protection Measures

The KNX TP1 bus network should be integrated into the protection measures of the mains power network.

The need for lightning protection for buildings may be the result of:

- ✚ the local building regulations (e.g. in Germany of the federal states);
- ✚ a risk analysis of the construction (e.g. in Germany according VDE 0815 part 2)
- ✚ a requirement from an insurance company (in Germany according VdS 2010).

In general, lightning protection measures are required for buildings which can be easily struck by lightning or to which lightning can inflict heavy damage. These especially include conference rooms, public buildings etc.

The internal lightning protection constitutes the most indispensable part of a lightning protection system. Its most significant component is the lightning protection equipotential bonding bar.

All conducting elements or systems, such as the water supply system, gas pipes, central heating system, metal walls, etc. must be connected to the equipotential bonding strip (EBS). In the currently valid guidelines (DIN VDE 0185 Part 1 to 4, IEC 1024-1, IEC 61312-1), the lightning protection equipotential bonding strip is a binding requirement also for active conductors; they must be indirectly connected by means of lightning surge arresters. This is referred to as 'primary protection'.

Primary protection is achieved by using:

✚ For the AC 230/400 V mains:

- nominal discharge current at least 12,5 kA (10/350  $\mu$ s) per conductor
- protection level: < 4 kV
- Surge protection device (SPD) Type 1 according EN 61643-11:2001

✚ For the bus line

- nominal discharge current at least 2,5 kA (10/350  $\mu$ s) per conductor
- protection level: < 600 V
- Surge protection device (SPD) Category D1 according 61643-21:2002

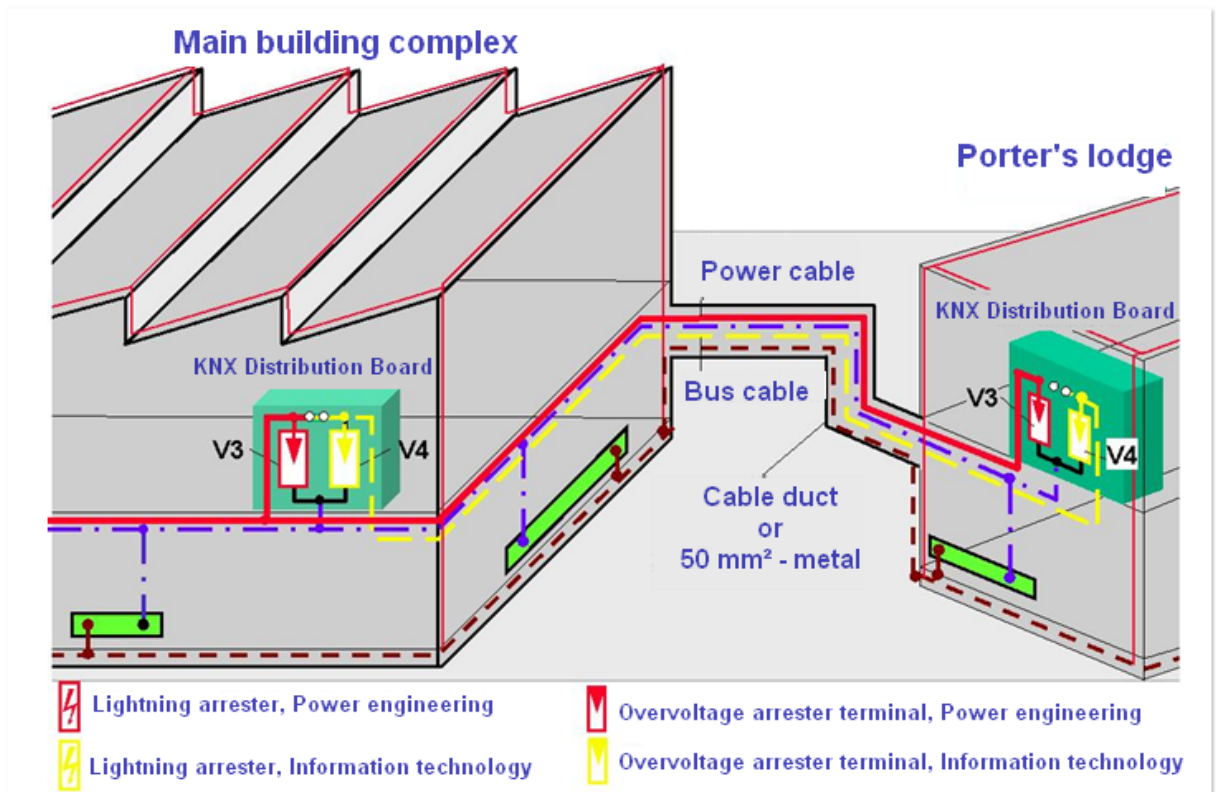

Figure 19: Bus cables installed between buildings

### 13 Bus Cables Installed between Buildings

If lightning protection measures have been installed, special measures **must** be taken if the installation contains bus cables that extend over more than one building. It is recommended to take these measures even if such lightning protection systems are not installed.

Either a lightning current arrester should be installed at the next corner of the building (which should be connected to the main equipotential bonding), or the bus cable should be installed in-between the buildings in a metal conduit or duct, which should be connected to earth on both sides, at the entrance to the building. In order to discharge parts of the lightning current, a minimum cross-sectional area of 16 mm<sup>2</sup> CU or 25 mm<sup>2</sup> Al or 50 mm<sup>2</sup> FE is required according to VDE 0185 part 3.

In either case, the connected bus devices in the building should be connected to an overvoltage arrester terminal for secondary protection. The bus devices and the overvoltage arrester terminal should be mounted apart at a distance of some (cable) metres to make sure that the overvoltage arrester terminal is not forced to accommodate parts of the primary protection.

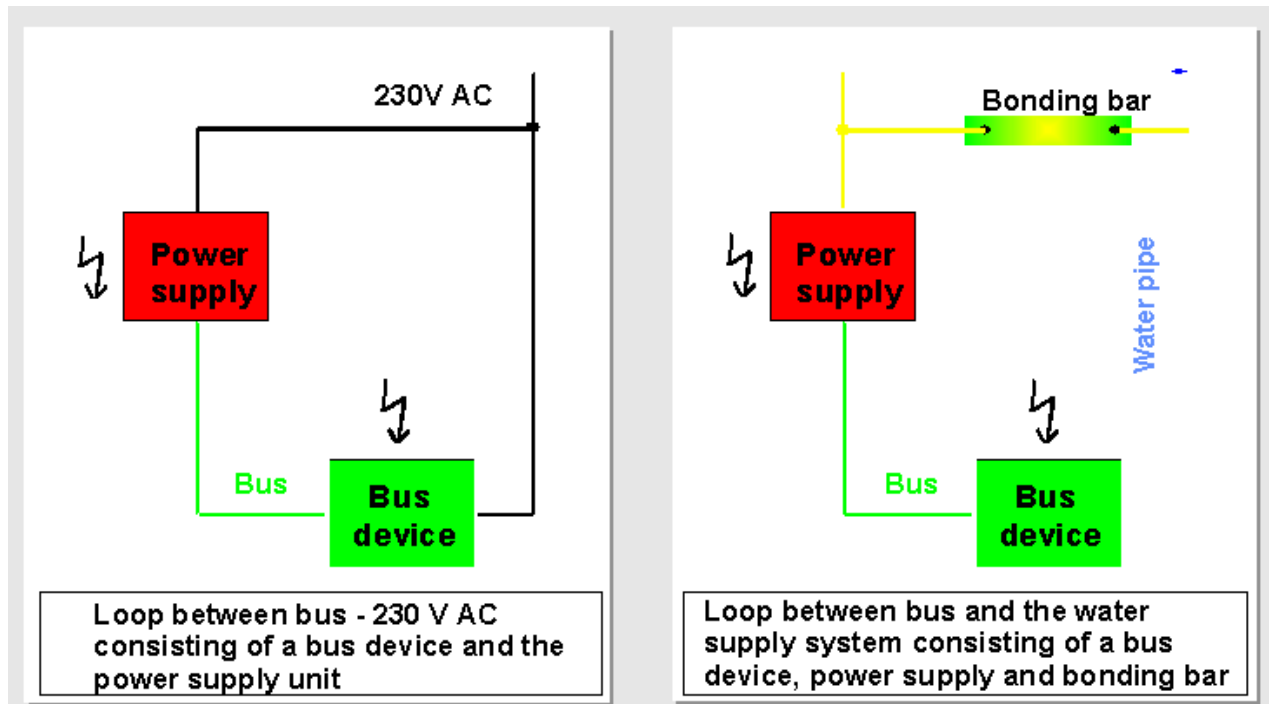

Figure 20: Prevention of loops

## 14 The Prevention of Loops

As a consequence of the impact of lightning, major overvoltages are generated in loops, which can cause flash-overs in bus devices. The larger the loop area, the larger the (peak) overvoltage to be expected.

Loops are created when for instance both the bus cable and the 230 V cable are connected to one bus device, as in this case also the power supply unit is connected to both networks. Both devices are therefore at risk when struck by lightning.

However, loops are also created when a connection is made to the water supply system, the central heating system, metal walls etc. The loop is closed by means of the equipotential bonding strip.

If possible, care should be taken as early as the planning stage to prevent the creation of loops. Bus and mains cables should be installed as close to each other as possible. An appropriate distance should be observed from the water supply or central heating system, etc. If line-crossing loops occur in a KNX TP1 installation, it may not be possible to program the installation under certain circumstances.



## 15 Basic Immunity of Bus Devices

The basic immunity of bus devices is tested according to the standard EN 50090-2-2 by applying a 2 kV surge voltage core to earth. As a consequence, bus devices are protected against overvoltages often caused by switching operations.

In general this provides sufficient protection.

More significant interference can however be caused:

- ✚ when bus cables and powerful mains are installed in parallel over a longer distance
- ✚ in the vicinity of lightning rods and arresters
- ✚ when bus lines and conductive parts of an installation (through which lightning current can flow) are installed in parallel
- ✚ in loops
- ✚ in bus devices connected to conductive sections such as metal walls, central heating pipes etc.

## 16 Bus Devices on Cable Ends

In this case, additional secondary protection should be provided.

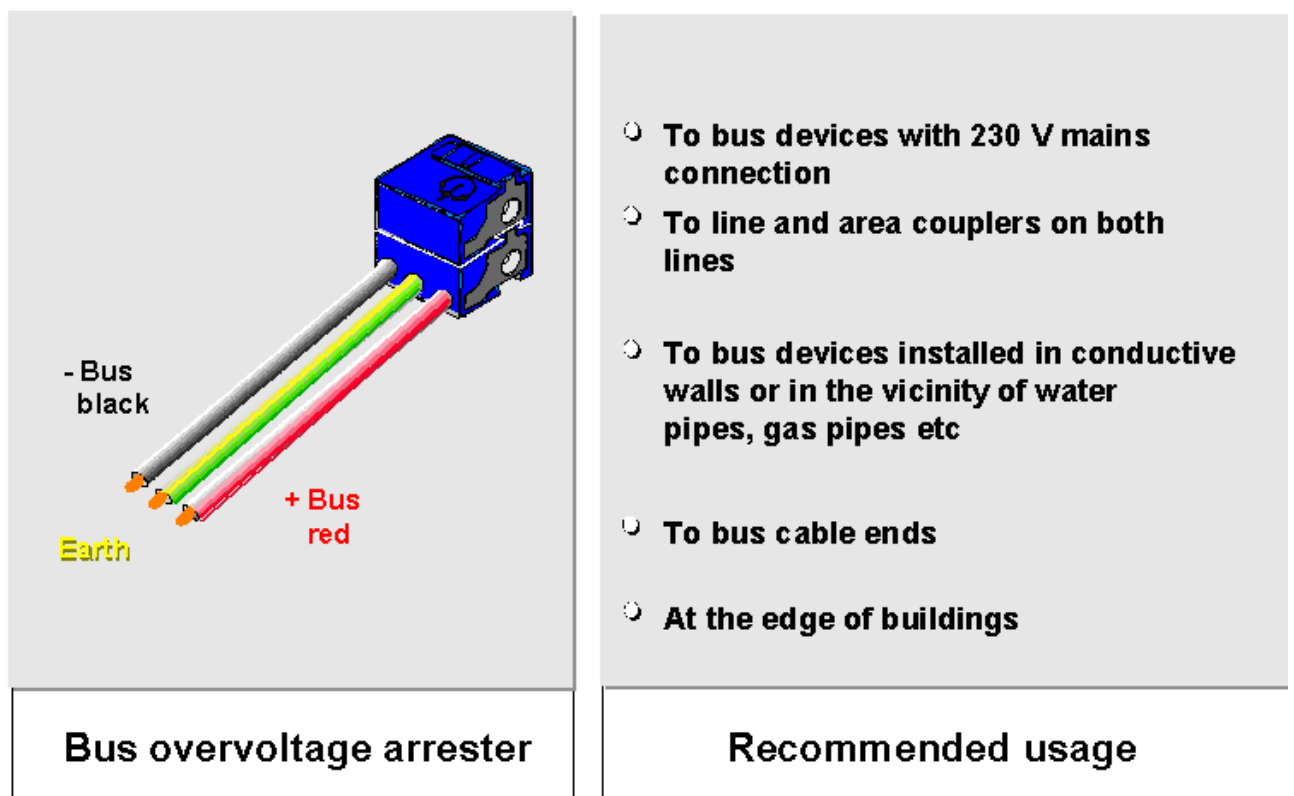

Figure 21: The overvoltage arrester terminal

## 17 The Overvoltage Arrester Terminal

The overvoltage arrester terminal should be used as a secondary protection and shall meet the following requirements:

- ✚ nominal discharge current at least 5 kA (8/20  $\mu$ s)
- ✚ protection level: < 350 V
- ✚ KNX certified

The overvoltage arrester terminal is a symmetrical safety device discharging both bus wires, thus preventing large voltage differences. Single pole arresters should not be used. Due to their higher capacity, varistors are not suitable for this purpose.

Via the connection wires sticking out of the bus overvoltage arrester (which have an identical colour marking as the bus cable, i.e. red and black), the arrester can be connected by means of a conventional bus connection block to the bus cable or directly to a bus device. However, the bus overvoltage arrester cannot be used to branch the bus cable. The third green connection wire is the earthing conductor which should be connected to the nearest earthing point of the installation (i.e. protective earth conductor). In the case of flush-mounted bus devices and couplers, the overvoltage arrester terminal is directly connected to the bus device instead of using a bus connection block. In this case, the connection between wires is ensured by means of an externally mounted bus connection block.

The arrester terminal also replaces the bus connection block when couplers are to be connected in the main line.

In the case of DIN rail mounted bus devices in general, e.g. power supply units and secondary lines of couplers, the overvoltage arrester terminal should be connected to a data rail connector.

The earthing conductor of the distribution board must be connected to the protective earth conductor (PE) by means of a **non-earthed** DIN rail terminal.

## 18 Recommendations to the use of overvoltage arresters

The use of overvoltage arresters is recommended for:

- ✚ bus devices with protection class 1
- ✚ bus devices with more connections than just bus (AC 230/400 V respectively conduits of the heating system)

In distribution boards, it is sufficient to equip each bus line with one overvoltage arrester. In this case also the outer conductor and the neutral conductor with overvoltage arresters. For luminaries with built-in switching actuators the installation of overvoltage arresters is only necessary when the bus and the mains form large-surface loops.

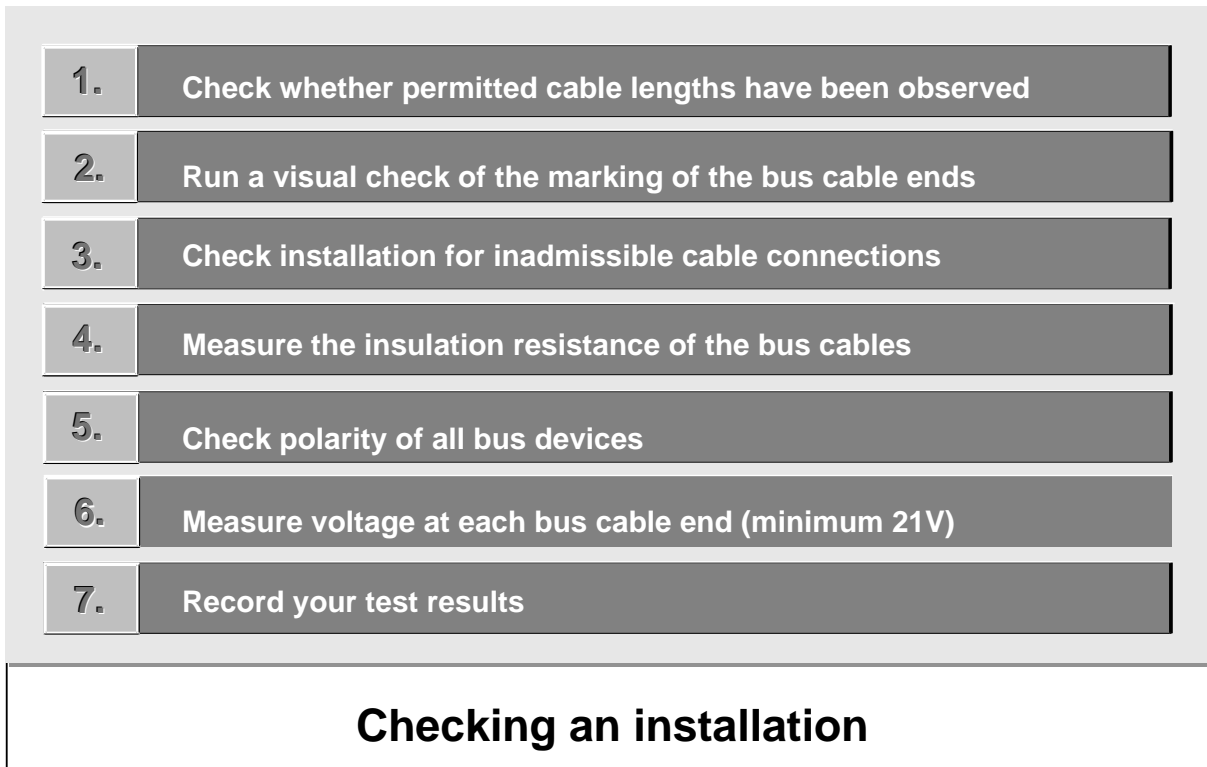

Figure 22: Checking the installation

## 19 Checking the Installation

- 1) Voltage drops and telegram run times occur due to the ohmic resistance, the capacity and inductance of the bus cables. This produces the physical limits of a KNX TP1 installation as outlined below.

Length of a line segment	<b>max. 1000 m</b>
Distance between power supply unit and bus device	<b>max. 350 m</b>
Distance between two power supply units, including chokes	<b>As specified by the manufacturer</b>
Distance between two bus devices	<b>max. 700 m</b>

It may be helpful to measure the loop resistance of the bus line under test.

2. The ends of the bus cables should be clearly identified as KNX TP1 installation bus cable by marking them *KNX TP1* or *BUS*. An extra indication of the area and line will make it easier to locate a specific bus cable for test, commissioning or maintenance.
3. Bus cables from different lines may never be linked together. Inadmissible connections between the individual lines can be checked by switching off the power supply unit of the line under test. If the power LED of the line coupler continues to light, an inadmissible connection has been detected.

4. The measurement of the isolation resistance of the bus cable should be carried out at DC 250 V (DIN VDE 0100 T600). The isolation resistance shall be at least 500 k $\Omega$ . The measurement is carried out as conductor against PE and not conductor against conductor.  
**Please note:** Overvoltage arrester terminals should always be removed before carrying out the test so that the measurement is not influenced and the overvoltage arrester is not damaged.
5. A polarity check should be carried out on all bus devices. To do so, set the bus device to the programming mode by pressing the programming button. If the programming LED lights up, the bus device is correctly connected. To finish the check, press the programming pushbutton again. This switches the bus device back to normal operating mode and resets the programming LED.
6. After having mounted all bus devices, check the bus voltage at the end of each bus cable using a voltmeter. The voltage should be at least 21 V.
7. Record all test results and add them to the documents of the KNX TP1 installation.

# KNX Project Design ETS4: Basic

KNX Association

## Table of contents

1	General information about ETS.....	4
1.1	General aspects .....	4
1.2	The ETS concept .....	4
1.3	System requirements .....	5
1.4	Installation of ETS .....	5
1.5	Licences .....	6
1.6	Project design with ETS – The principles .....	8
1.7	Starting ETS.....	9
1.8	Dashboard tabs.....	10
1.8.1	Overview tab .....	10
1.8.2	Projects tab .....	11
1.8.3	Catalogs tab .....	11
1.8.4	Database tab .....	12
1.8.5	Settings tab .....	14
1.9	The import functions.....	15
1.9.1	Product data import .....	16
1.9.2	Project import .....	18
1.9.3	Particularities for plug-in software.....	18
1.10	The export functions.....	19
2	Opening a project with ETS .....	20
2.1	Creating a new project .....	20
2.2	Opening existing projects .....	21
2.3	Project details.....	22
2.3.1	General index card .....	22
2.3.2	Project log index card .....	23
2.3.3	Project files index card .....	23
2.4	Project design views.....	23
2.4.1	Buildings window .....	25
2.4.2	Group Addresses window.....	26
2.4.3	Topology window .....	27
2.4.4	Devices window .....	28
2.4.5	Project Root window and Catalogs window .....	28
2.4.6	Side Bar .....	28
3	Quick project design with ETS .....	29
3.1	Starting the project design.....	29
3.2	Creating a building structure.....	30
3.3	Product Finder.....	31
3.3.1	Finding products.....	32

---

3.3.2	Inserting devices .....	32
3.4	Properties of the devices .....	33
3.4.1	Product information .....	33
3.5	Device parameters .....	34
3.6	Editing group objects.....	35
3.6.1	Setting the flags.....	36
3.7	Configuring group addresses .....	38
3.8	Assignment of group addresses .....	39
3.8.1	Sending group address .....	40
3.8.2	Group speaker flag.....	41

## 1 General information about ETS

### 1.1 General aspects

*KNX* is a fully integrated system for home and building automation for the implementation of upward compatible, flexible and cost-effective solutions. Its functional versatility cannot only be used in simple and limited installations but also enables solutions for the entire building sector. *KNX* thus corresponds to the requirements of the electrical trade including project design and installation, commissioning, operation of the bus system and maintenance.

The planning, project design and commissioning of a *KNX* installation requires a software tool for building designers and electrical installers that is clearly structured and simple to use.

An extensive online Help file is available to the user. The user can at any time access help for the currently opened window via the F1 button.

The project design of a building, in which *KNX* should be used, initially does not differ from conventional electrical planning. The following aspects must be clarified by the planner in the preliminary stages:

- ✚ the type and use of the building,
- ✚ the building system components that are to be implemented and their functions,
- ✚ type and frequency of changes of use,
- ✚ special requirements of the clients,
- ✚ budget

The planning of the electrical installation is carried out as for a conventional installation according to the generally recognised rules of technology, the connection conditions of the utility as well as the usual planning guidelines, supplementary regulations and dimensioning provisions.

### 1.2 The ETS concept





For the planning, project design and commissioning of *KNX* systems, a uniform program for the project design and commissioning of the *KNX* system is available for planners and installers. ETS stands for Engineering Tool Software. ETS™ is a registered trademark of the *KNX* Association. ETS4 is the current version of ETS. On the one hand, ETS4 is a newly developed software program: during its development particular emphasis was placed on keeping the user interface very similar to that of the previous versions.

On the other hand, the display and operating philosophy of the user interface of ETS4 has been completely reworked. Display and operation has been adapted to current standards. In this way, operation and orientation has been clearly simplified in comparison to ETS3.



### 1.3 System requirements

The following operating systems (as 32/64 bit) are supported in principle:

-  MS Windows XP
-  MS Windows Vista
-  MS Windows 7
-  MS Windows 8
-  MS Windows Server 2003/2008

Details about this and the required hardware can be found on the KNX home page on <http://www.knx.org/knx-tools/ETS/requirements/>.

### 1.4 Installation of ETS

You can only obtain ETS from KNX Association via internet in the KNX online shop (address <https://onlineshop.knx.org>.)

If you have downloaded the software from the internet and have unzipped the downloaded file, you start the installation by executing the installation program *ETS4Setup.exe*.

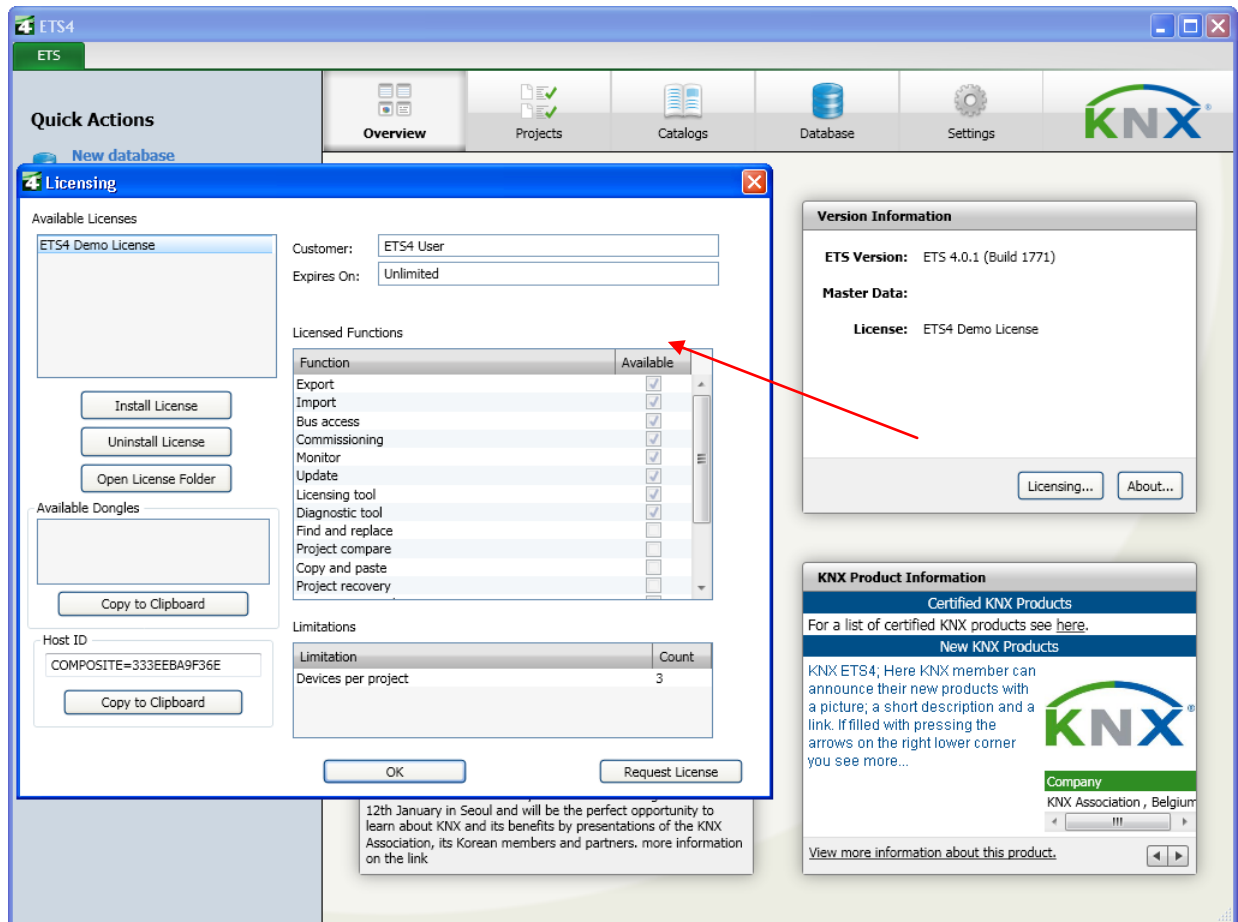

Figure 1: Licensing

## 1.5 Licences

There are four versions available, all as a PC-dependent key or a non PC-dependant dongle (except for the demo):

- ✚ **Demo:** Full functionality, max. 3 devices per project, this version is free of charge.
- ✚ **Lite:** Full functionality, max. 20 devices per project.
- ✚ **Professional:** Full functionality, no restrictions as regards number of devices which can be installed and the number of projects which can be created
- ✚ There is also the **Supplementary** version. This version is intended as an additional licence for the full Professional version on a second PC (commissioning PC/Notebook).

In all cases, the ETS program is installed in full. The mode, in which ETS subsequently runs, depends on the type of licence key. After installation, the program first runs as a demo version. You can start the process for purchasing and installing licences, by clicking the *Licensing...* button in the *Version Information* box in the ETS dash board, which is opened after starting ETS.

Pressing the *Request Licence* button leads directly to the KNX online shop. This requires an active online connection. On the pages of the online shop, you will also find detailed information about the licensing process.

The following key types exist:

- ✚ PC dependent key: this key activates the license only on the PC on which the ETS license has been installed.
- ✚ PC independent key: this key does not refer to the PC hardware, but refers to a “dongle” which also has to be ordered from KNX Association. This dongle must be inserted in the USB port of the computer. This type of key is a little bit more expensive

ETS also allows distant configuration or maintenance of installations (via Internet, called iETS)

Since the introduction of ETS 4.1 it is possible to extend the functionality of ETS via programs called “Apps”. These Apps are also available in the KNX Online Shop and they are licensed in the same way as described before. Some Apps are developed by KNX Association, others by KNX manufacturers. Examples of such Apps are: online product catalog, graphical configuration of ETS projects, Project compare, Replace product.... For some of these apps a fee needs to be paid.

In order to prepare yourself for a future KNX basic course and to get acquainted with ETS, you can sign up for the ETS eCampus. This is free of charge and you only need to register yourself in the Online Shop.

## 1.6 Project design with ETS – The principles

The following steps represent the chronological order for project design with ETS.

- ✚ Carry out the ETS settings
- ✚ Read in or convert product databases
- ✚ Create the project with the necessary data
- ✚ Set up the structure of the project (building structure/bus topology)
- ✚ Insert KNX products (devices with corresponding application) into the building structure
- ✚ Set the parameters of the KNX products according to requirements
- ✚ Create group addresses
- ✚ Link the group objects of the KNX products with the group addresses
- ✚ Assign the configured KNX products to the bus topology (final definition of the individual address)
- ✚ Assign the configured KNX products to the installed functions (optional)
- ✚ Check the project design
- ✚ Print out the documentation
- ✚ Save the project

It is possible to deviate from this sequence in individual cases. Some steps can be omitted for smaller projects. Additional steps are necessary in large projects (team projects).

## 1.7 Starting ETS

After the installation, ETS can be started by clicking the icon

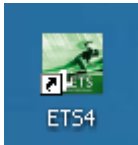

on the desktop or via the newly created program group called KNX.

When you open up ETS, a window appears which is referred to as the dashboard.

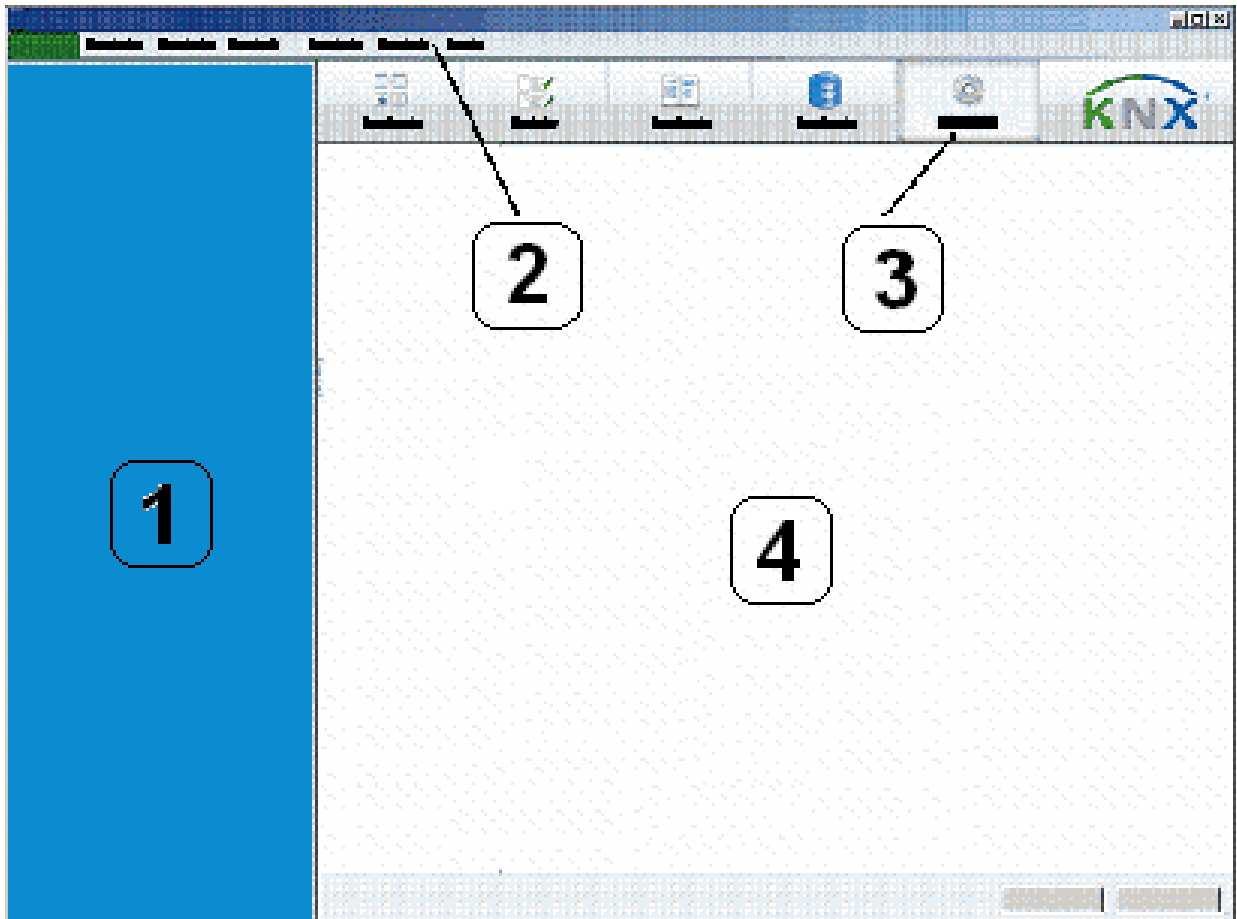

**Figure 2: “Dashboard”**

It contains the following elements:

A “Quick Actions” bar (1) for frequently required functions.

A menu bar (2). If you click on elements of the menu bar, you directly access the project design view of ETS.

A tab (3) via which you select what is currently displayed in the workspace (4).

You can access the dashboard again at any time by clicking on the small green ETS field in the top left-hand corner of the ETS window.

## 1.8 Dashboard tabs

### 1.8.1 Overview tab

When ETS is opened, the *Overview* tab is selected so that the fields displayed in figure 3 are visible in the workspace:

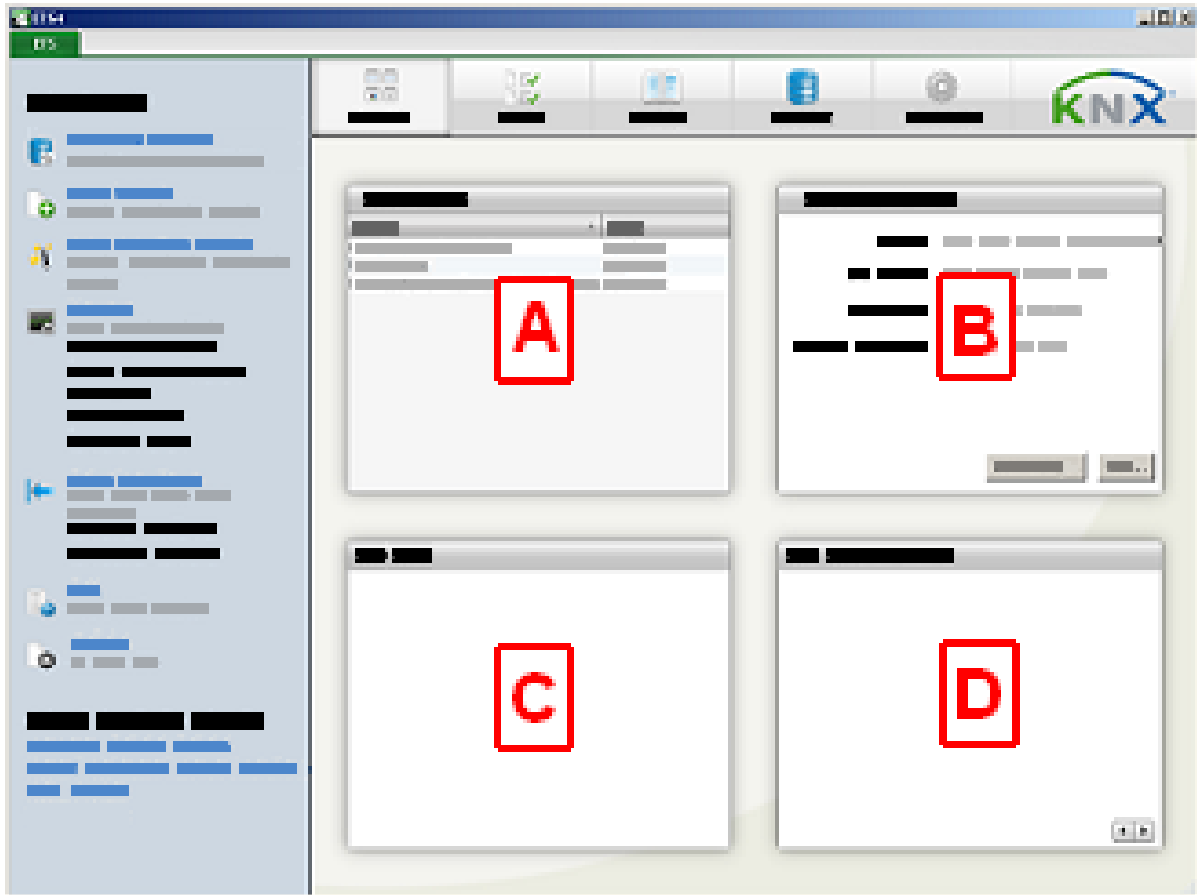

**Figure 3: Dashboard, Overview tab selected**

By double clicking on a project in window area A, you select the project that is to be edited. Via area B, you access the licensing feature. If you have an existing connection to the internet, current news about the KNX Association is shown in areas C and D.

## 1.8.2 Projects tab

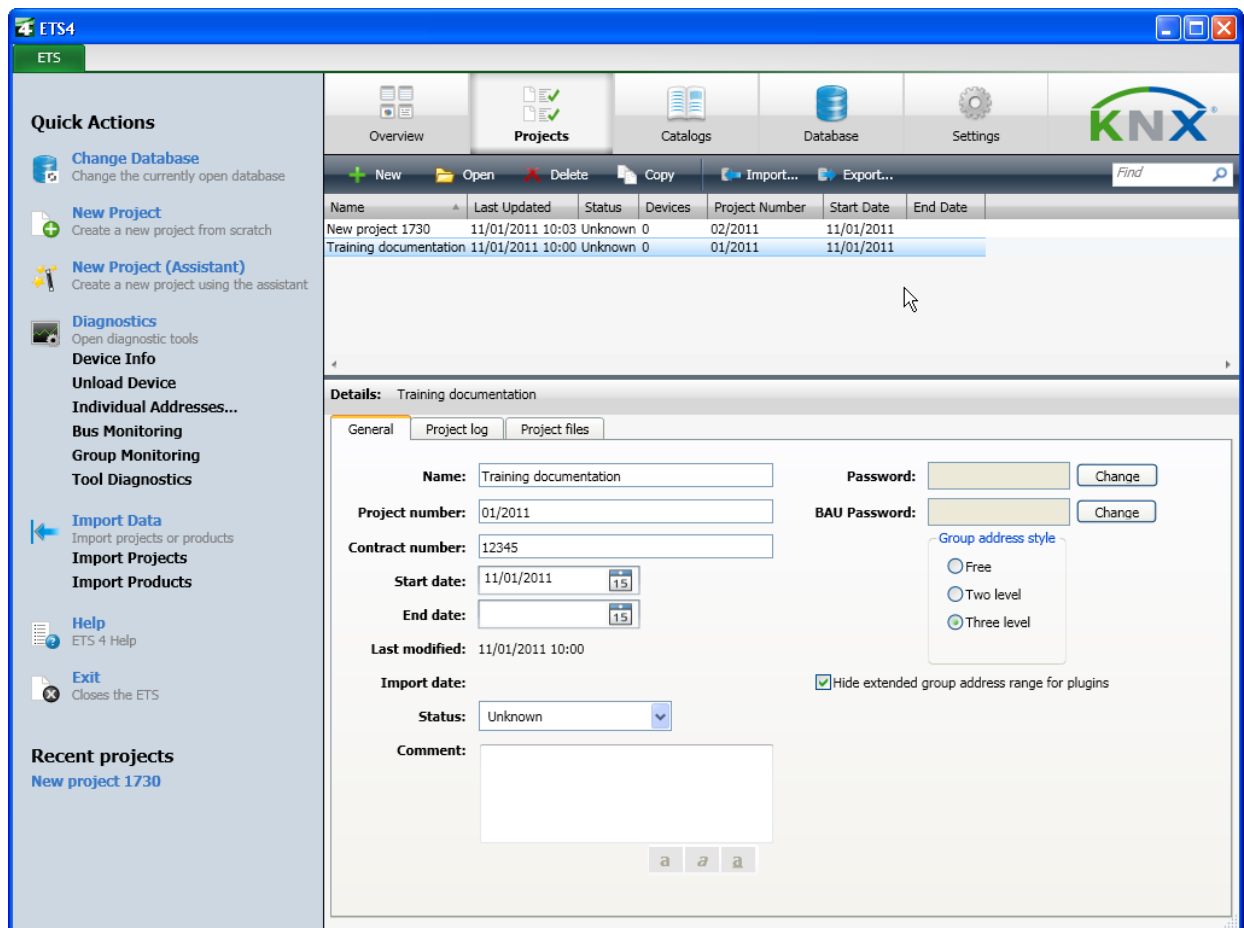

**Figure 4: Dashboard, Projects tab selected**

You can create a new project here, select a project for editing and set the properties of the projects. Further information can be found below in section 2: “Opening a project with ETS”.

Projects can likewise be imported and exported via this window. Further information about the import and export is described below in a separate section.

## 1.8.3 Catalogs tab

The product data of the manufacturers is managed under *Catalogs*.

After the installation, the ETS database is empty. To be able to work with ETS, product data from the manufacturers must be imported into this database. The import function of ETS is used for this purpose. Details about the import and export are described below in a separate section.

The manufacturers' product databases can be obtained free of charge on a CD or via the internet.

The window that is shown after selecting the *Catalogs* tab is displayed again during the project design stage when selecting devices. This window is therefore described in more detail further down in this section (see: Catalogs)

### 1.8.4 Database tab

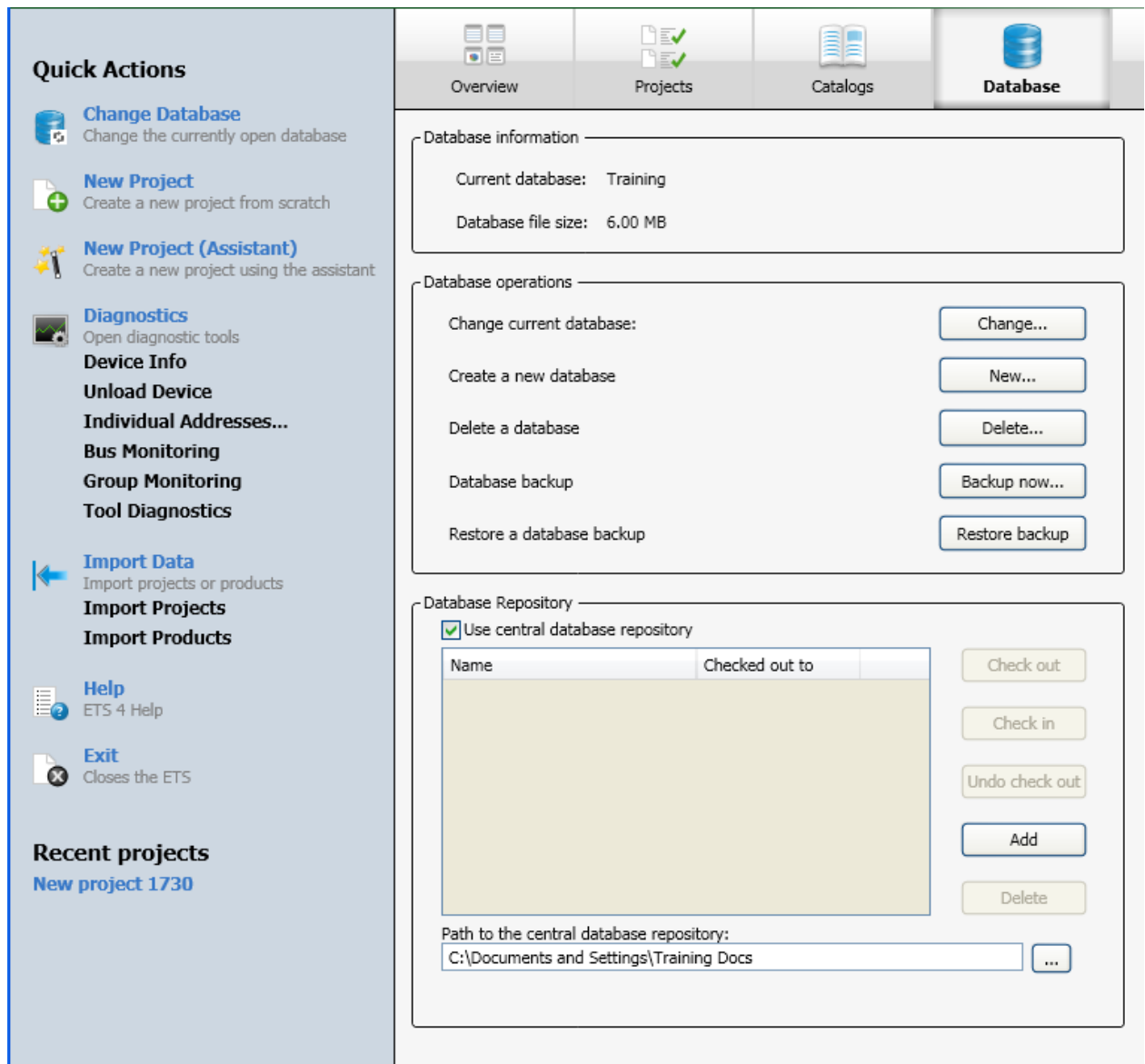
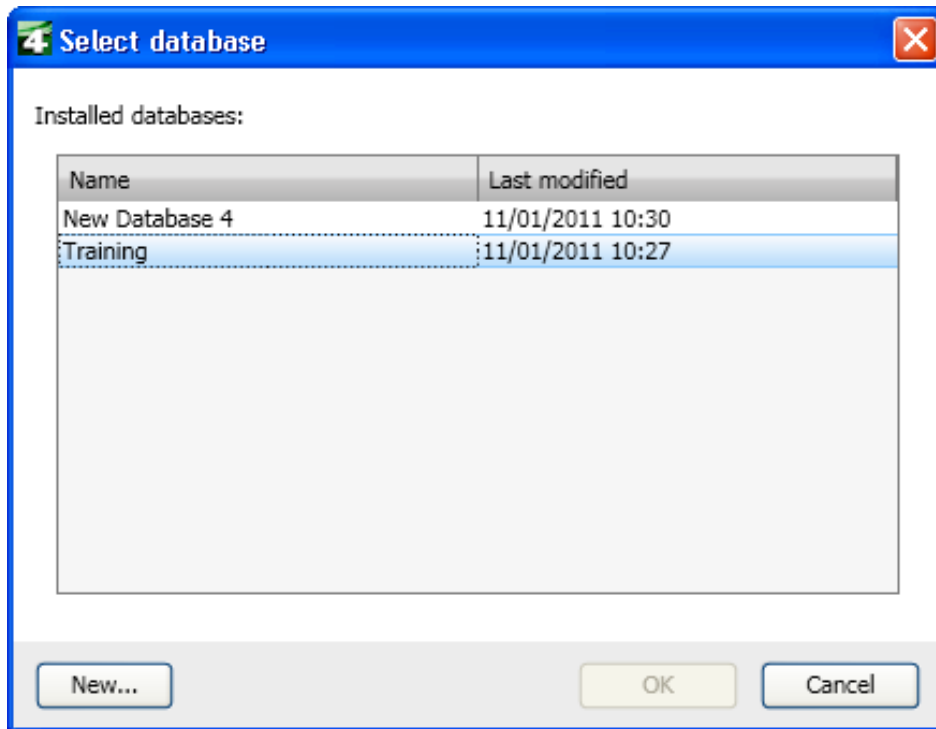

**Figure 5: Dashboard, Database tab selected**

In the *Database* window, you can select the currently edited database, generate a new database or create a backup of the database.

Select database: If you are working with several databases, you can select here the database you wish to use. You can specify under *Settings* (see next tab) in which directory the databases are located.





**Figure 6: Select database**

- You can likewise **generate a new database** via the *New...* button. The result is however an empty database, into which you need to import the product data of the manufacturers.
- **Backup now** or **Restore backup**. You require this function on the one hand to create a backup copy of your database and on the other hand to port a database to another computer. The file that was created during the backup process must be inserted via the option *Restore backup* on the other computer. Only then does ETS work with this database. A database that has simply been copied cannot be handled by ETS (protective function of the MS database system).  
An automatic backup function can also be set under the *Settings* tab. Further details about this can be found in the explanatory notes on the settings.
- **Central database repository**

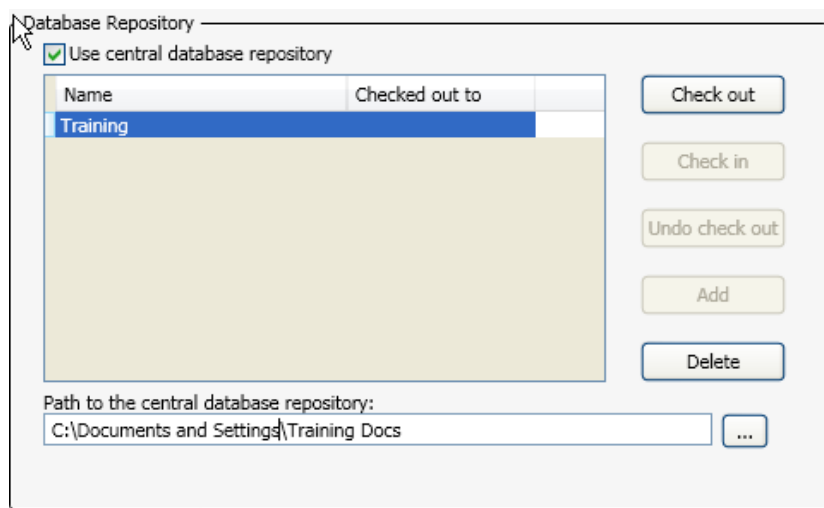

**Figure 7: Central database repository**

- A further function under the *Database* tab makes it possible to store the database not on the local computer but e.g. on a network drive. This is especially useful, when working with several users in one database. However, only one user can work with the database at one time. If required, you must select the option *Use central database repository* and when you wish to work with this database, you must check out this database to avoid that some else simultaneously carries out changes to the database content. Once you have finished editing the database, you must check this database back into the central database repository again. A prerequisite for this procedure is that the database in question has only been added once to the central database repository. The path of the central database repository can also be entered in this window.

### 1.8.5 Settings tab

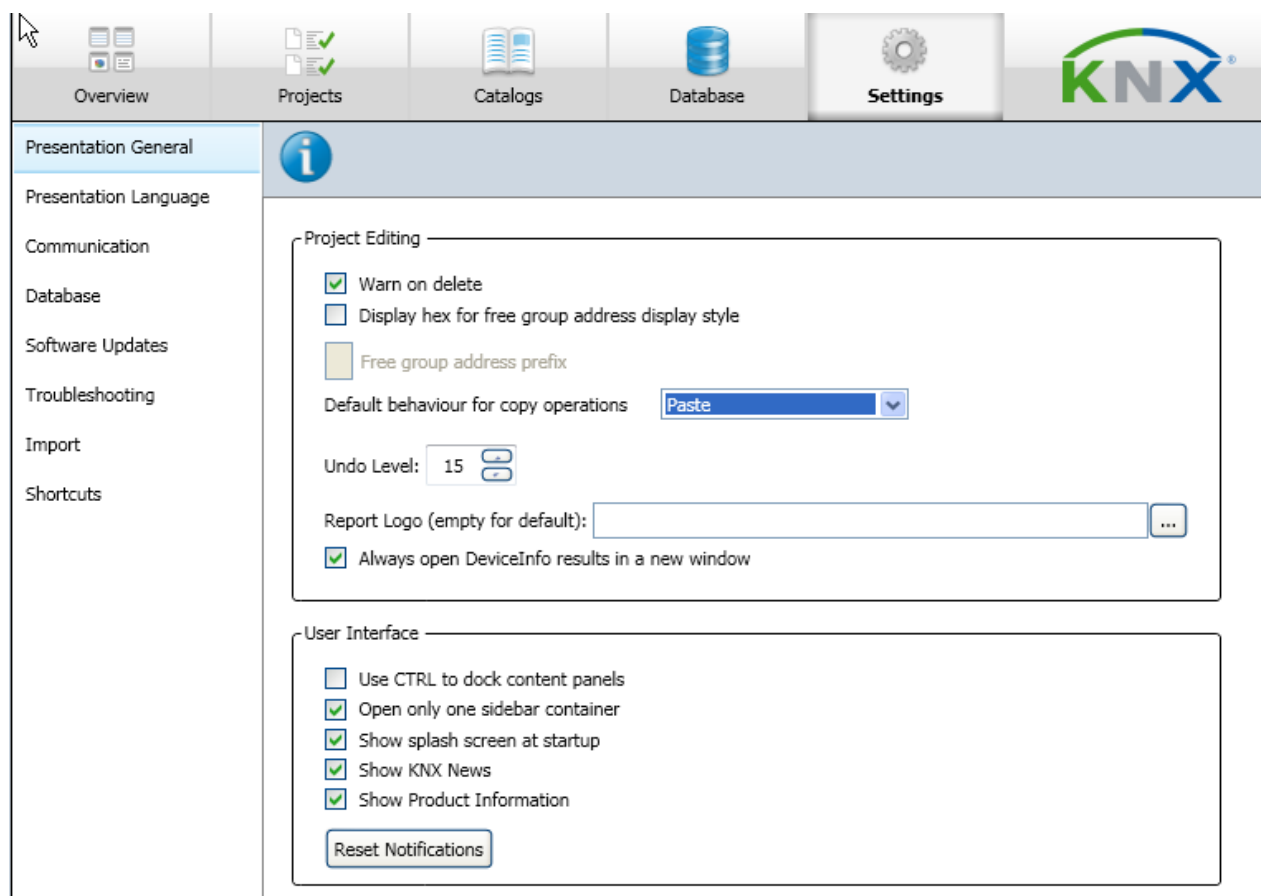
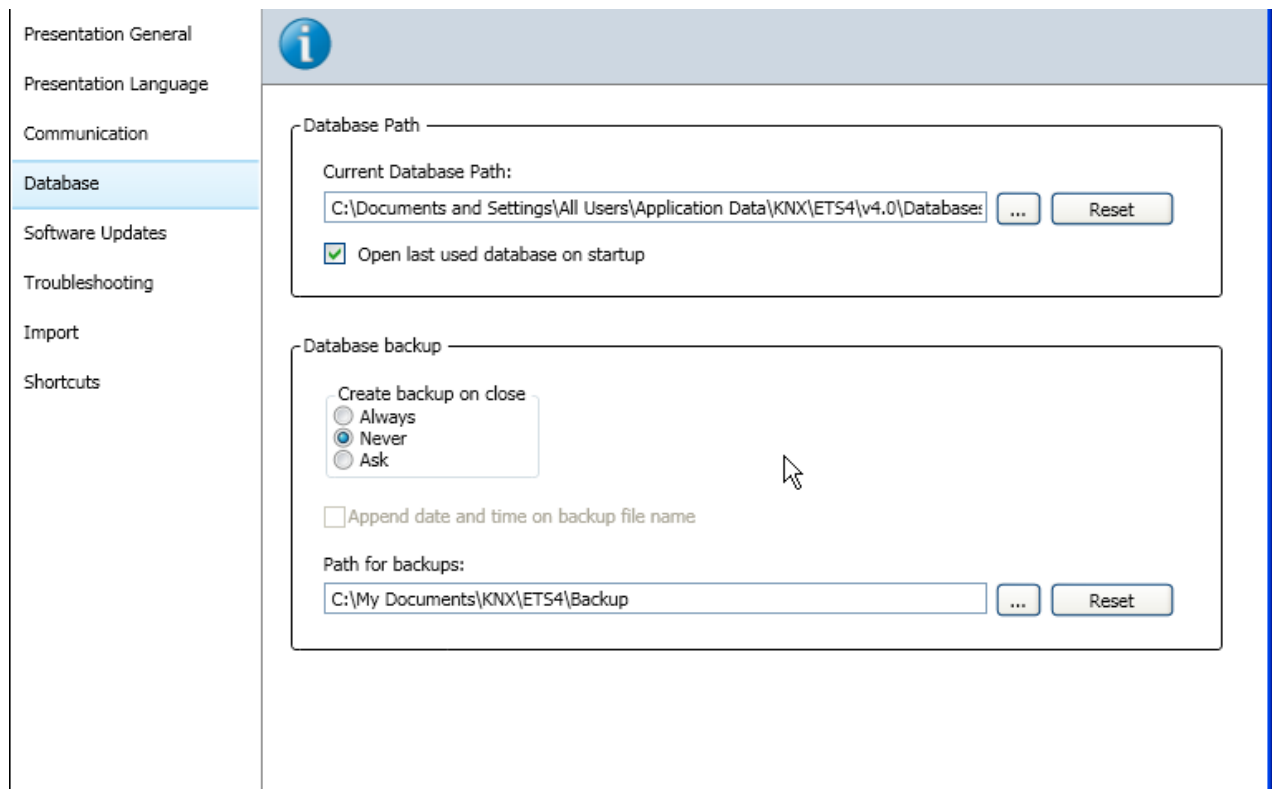

**Figure 8: Dashboard, Settings tab selected**

The settings are divided over eight different areas, which one can select by clicking on the terms in the left half of the window:

- ✚ **Presentation General.** Here you can influence the properties and appearance of ETS in some cases. For details, please refer to the online Help feature in ETS.
- ✚ **Presentation Language.** Here you can select the language of ETS.
- ✚ **Communication.** Here you can set the interface that is used for bus access. For details about this topic, please refer to the commissioning chapter of this training documentation.

## Database



**Figure 9: Dashboard, Settings tab, Database submenu**

In addition to selecting the path where the ETS databases should be stored, you can select here, whether you wish to create a backup each time you close ETS. If you have ticked the option *Append date and time on backup file name*, the current date and time is attached to the file name for each backup file.

- + **Software Updates.** When enabled, ETS checks automatically via the internet whether there are new updates of ETS available. If this is the case, ETS signals this and the new update is installed if requested.
- + **Troubleshooting.** Here you define the logging level for documenting your work in ETS log files for potential troubleshooting by the KNX Association.
- + **Import.** Setting the behaviour of the Import Wizard and the installation of plug-ins. For further details, see below under the description of the import functions.
- + **Shortcuts.** Here all shortcuts are displayed, which can be adapted according to your habits. Shortcuts enable the experienced user to work quicker with ETS.

## 1.9 The import functions

The import function enables both the import of product data as well as projects. You can retrieve this function from different places in ETS. This can be done via the “Quick Actions” bar on the dashboard and in the *Projects* and *Catalogs* tabs via the *Import...* button. You can also retrieve the import function at any time when working in the project design view of ETS by selecting the *Import...* button in the *Catalogs* window.

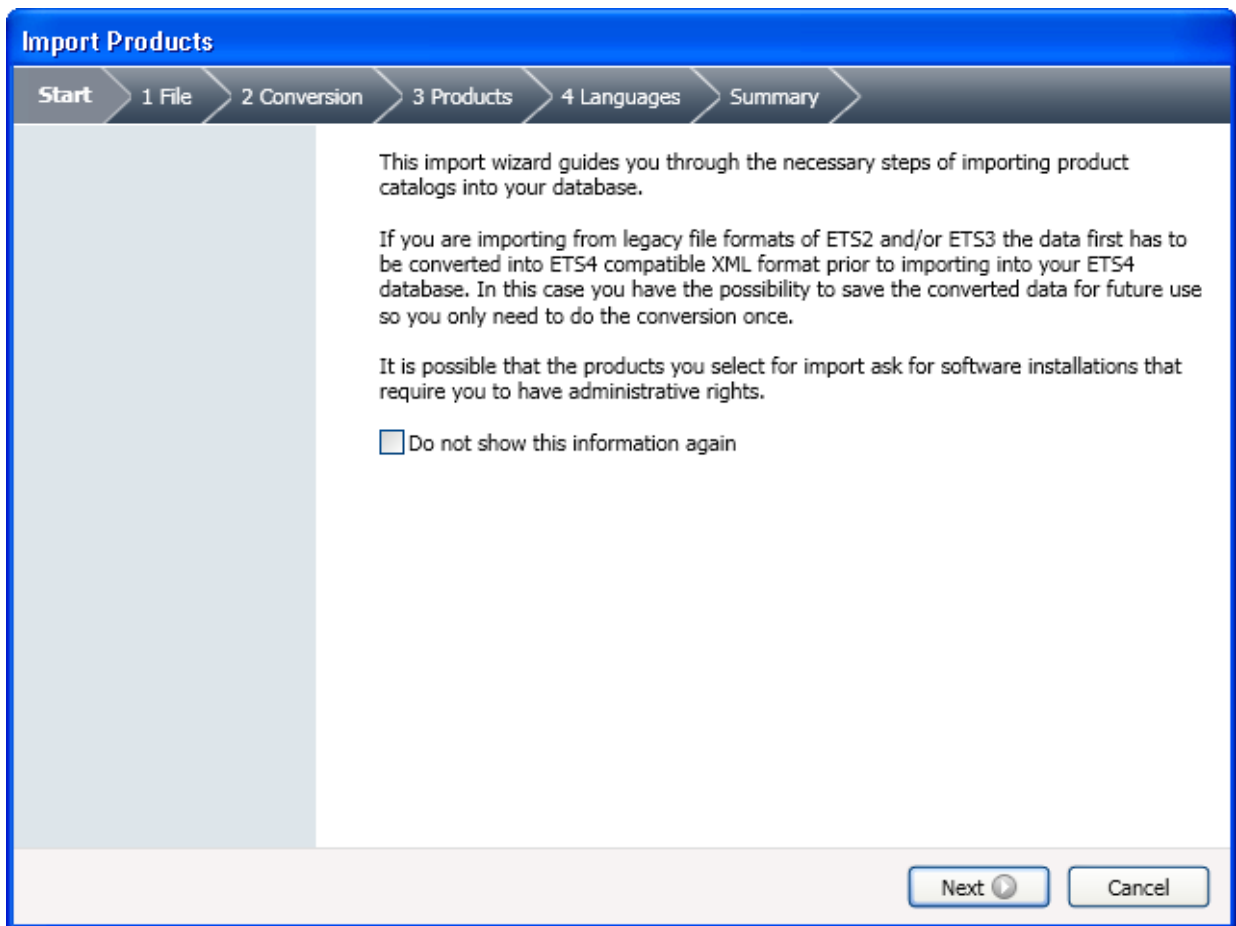

**Figure 10: Import Wizard**

When importing data, one can be guided by the Import Wizard, which is particularly advisable in the beginning. To do so, this function must be enabled in the ETS settings (see section 1.8.5).

### 1.9.1 Product data import

You can obtain product data from the manufacturers either on a CD or via the internet. It is also possible to import product data from existing ETS3 databases.

Databases from which you can import data can be recognised by their file extensions:

- ✚ Files with the extension `.knxprod` are databases in XML data format for ETS4.
- ✚ Product databases for ETS3 and ETS2 have the file extension `.vd?`. The question mark stands for the numbers 1 – 5 or an x, depending on which ETS version the data was originally intended for.
- ✚ Databases with the ending `.db` are databases from ETS3 or ETS2.

You select a file by pressing the  button in the Import Wizard on page **1 File**. You will then see the selection box displayed in the screenshot. This window is also directly displayed, if the export function is retrieved without Wizard.

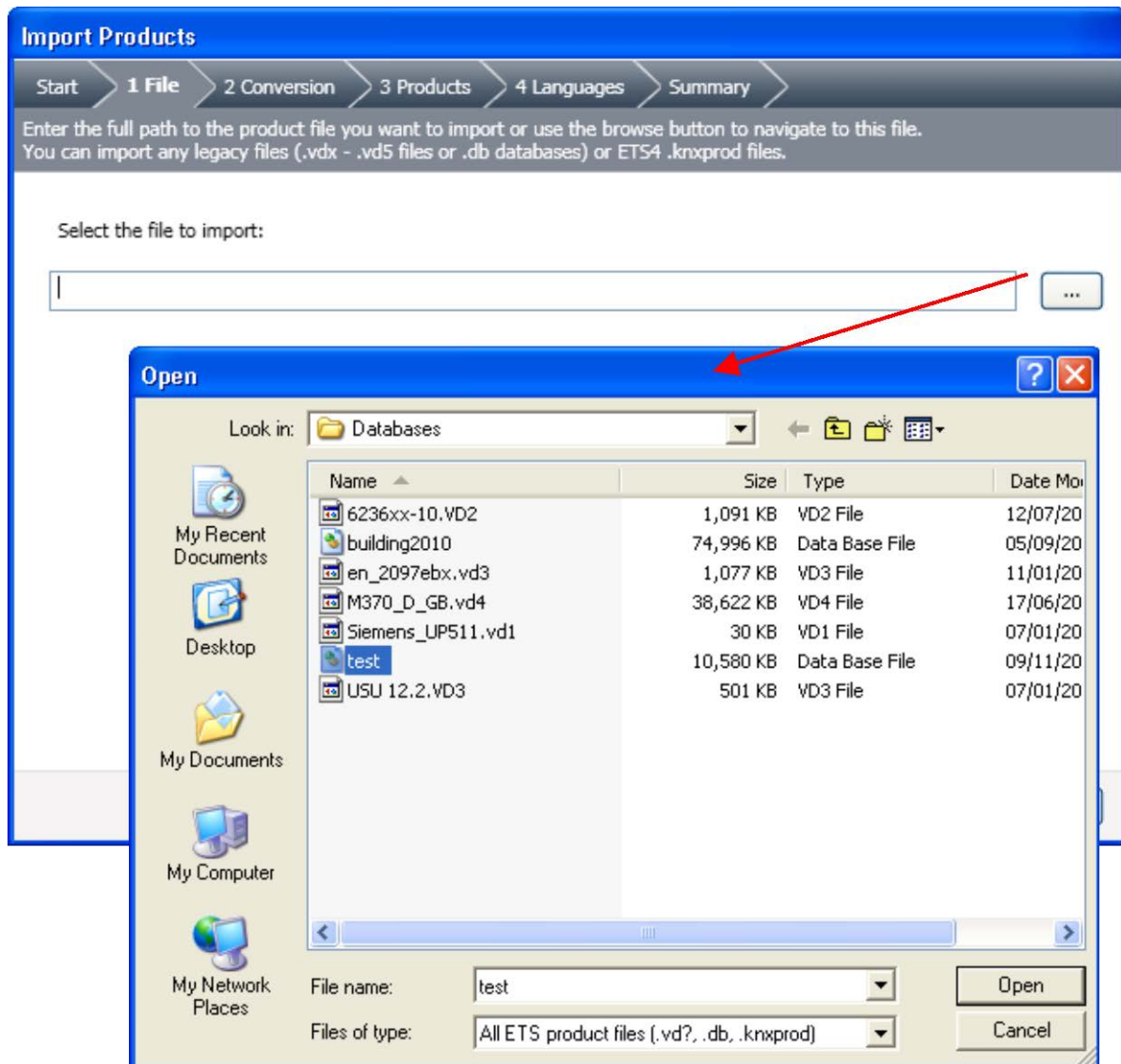
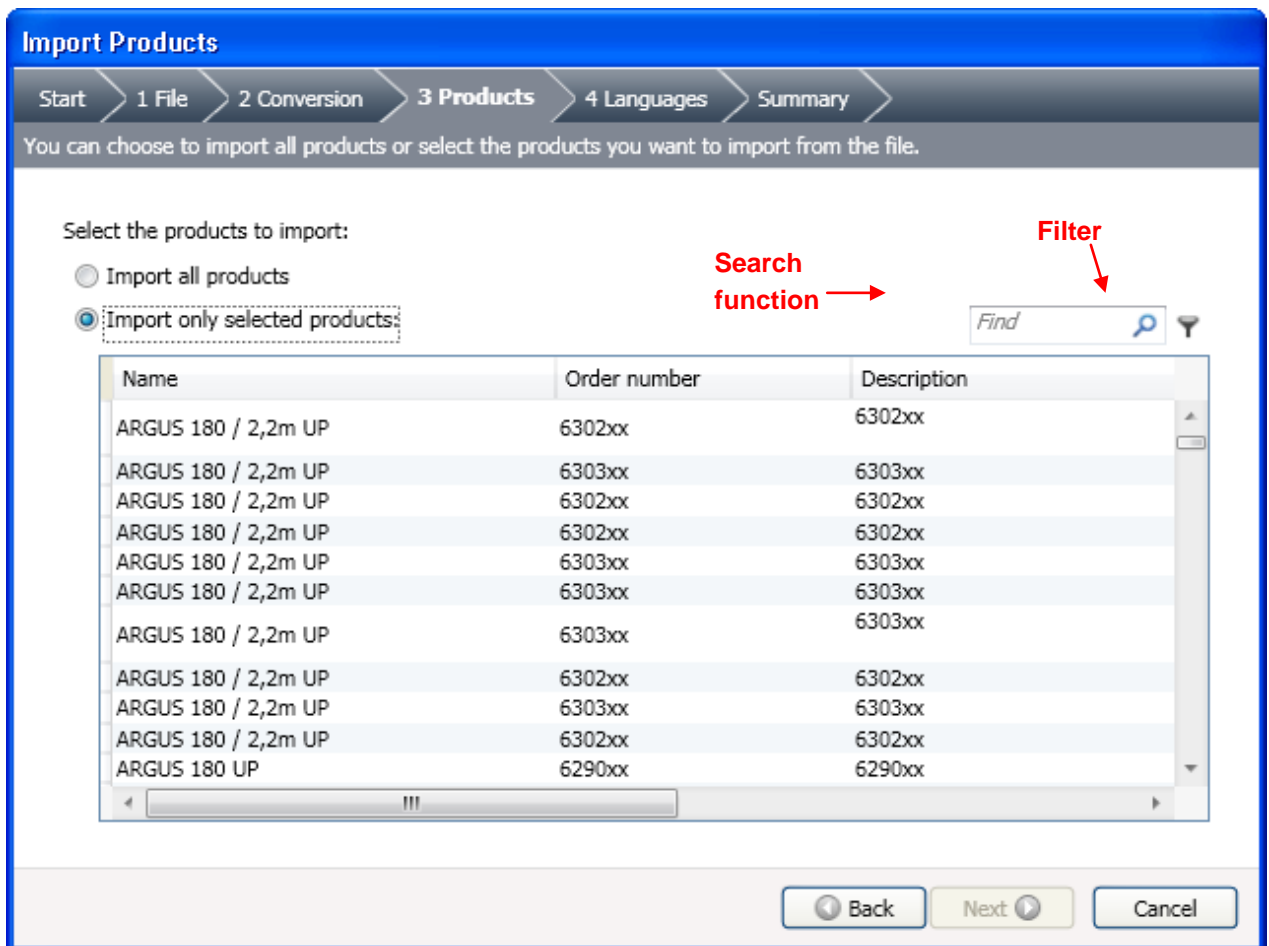

**Figure 11: Import Wizard, file selection**

Product data of previous ETS versions is converted by ETS into XML format. On the next page of the Import Wizard you are asked whether you wish to save the converted files, to avoid having to convert again during later imports.

Take care when importing files from CDs. If you have selected the option *Save the converted output file*, the point of origin of the file is entered automatically as the location where the converted file will be stored. In the case of CDs, this leads to problems as it is not generally possible to write to a CD. You should therefore in this case select a path that is also writeable.

If you do not wish to import the complete product database of a manufacturer, you can select which products you wish to import on the next page of the Import Wizard. For this, you must first select *Import only selected products*. A list of all the existing products in the database is subsequently created and displayed. When selecting the products, a search function and a filter function are available. Mark any products that are to be imported simply by clicking on them. With the help of the Shift key, you can mark a whole range of products. With the Ctrl button, you can select several products.



**Figure 12: Import Wizard, product selection**

Finally you can select whether you wish to import all existing languages of the text of the product data (parameter dialogs, etc.) in your database or only those you have selected. If you do not import all languages, the import process is faster and your database remains smaller.

Before the start of the import process, a summary shows you again what you have selected.

### 1.9.2 Project import

The import of projects follows the same pattern as the product data import. During the project import, all project design data such as building structure, comments, group addresses, individual addresses etc. of the corresponding project is imported. In addition, all required product data of the devices contained in this project is imported as well. You can retrieve the project import function on the *Dashboard* via the “Quick Actions” bar and under the *Projects* tab via the *Import...* button.

### 1.9.3 Particularities for plug-in software

The following explanatory notes concern both product as well as project data imports for projects containing devices with plug-in software.

For many products, additional software is installed when importing the manufacturer data in the ETS database, called ‘plug-in software’. You can now decide whether these plug-ins should always be installed immediately after the import or at a later date or after a

single request. They are only required by ETS when the device is retrieved for the first time. If a plug-in had not yet been installed, this can be done at this point. This however frequently requires administrator rights. Many users therefore prefer plug-ins to be installed immediately. Sometimes installation of plug-ins can require a considerable amount of time. In this case, the immediate installation of the plug-in is skipped, particularly if all products of a manufacturer should be imported at once. Whether the plug-in should be installed immediately or not, can be set in the *Settings* tab under the *Import* submenu on the dashboard (see section 1.8.5).

## 1.10 The export functions

You can export product data and entire projects from an ETS database.

### **Product data export**

Product data export is possible from two windows: from the *Catalogs* tab on the dashboard and in the project design from the *Product Finder* window. Depending on the selection in the respective window, individual products, whole product groups, all the products of a manufacturer or all the products of this database are exported. A file with the extension *.knxprod* is created.

The data format of this file is XML and the products can be imported back into an ETS database. It is not possible to create product data for importing into older ETS versions.

### **Project export**

if in the project administration area and by selecting the *Projects* tab on the dashboard, one is able to export a project. All the project-related data is exported into a file with extension *.knxproj*. This file also contains the entire product data of all devices used in this project, so that you can work on the project immediately after importing it into an empty database.

## 2 Opening a project with ETS

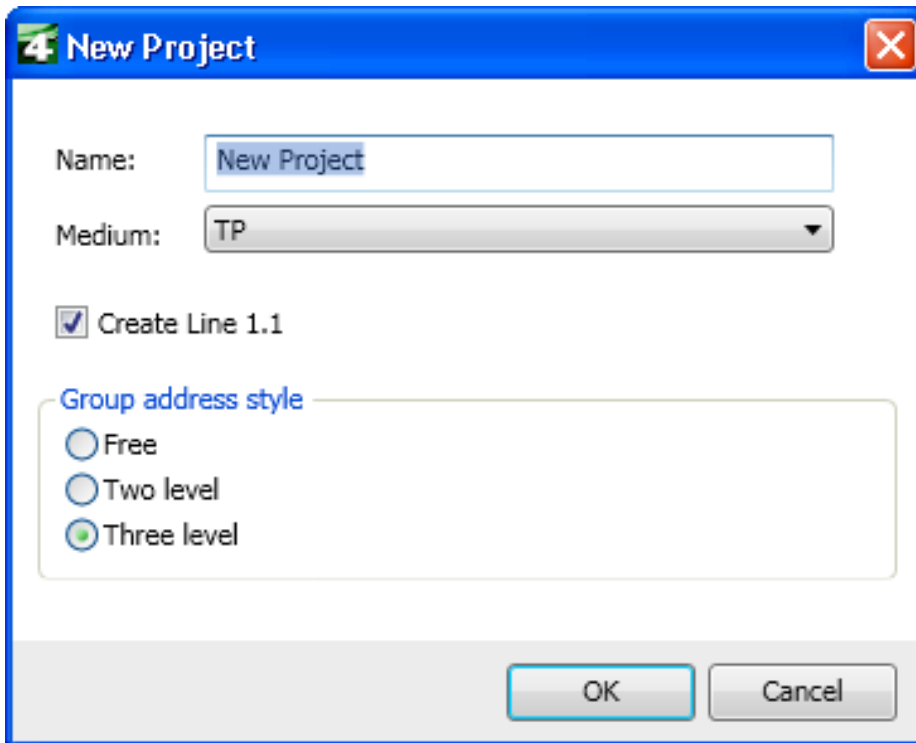



Figure 13: Creating a new project

### 2.1 Creating a new project

A new project can be created on the dashboard via the *New Project* function of the “Quick Actions” bar or under the *Projects* tab via the  button. The *New Project* dialog appears on the screen. A name must be entered in this dialog window. The medium that has been used is also specified here (TP for Twisted Pair, PL for Powerline and IP for Ethernet). If you have selected the function *Create Line 1.1*, the area 1, main line 1.0 and line 1.1 are created immediately. Otherwise the project has no topology structure. Finally, one can set the group address style.



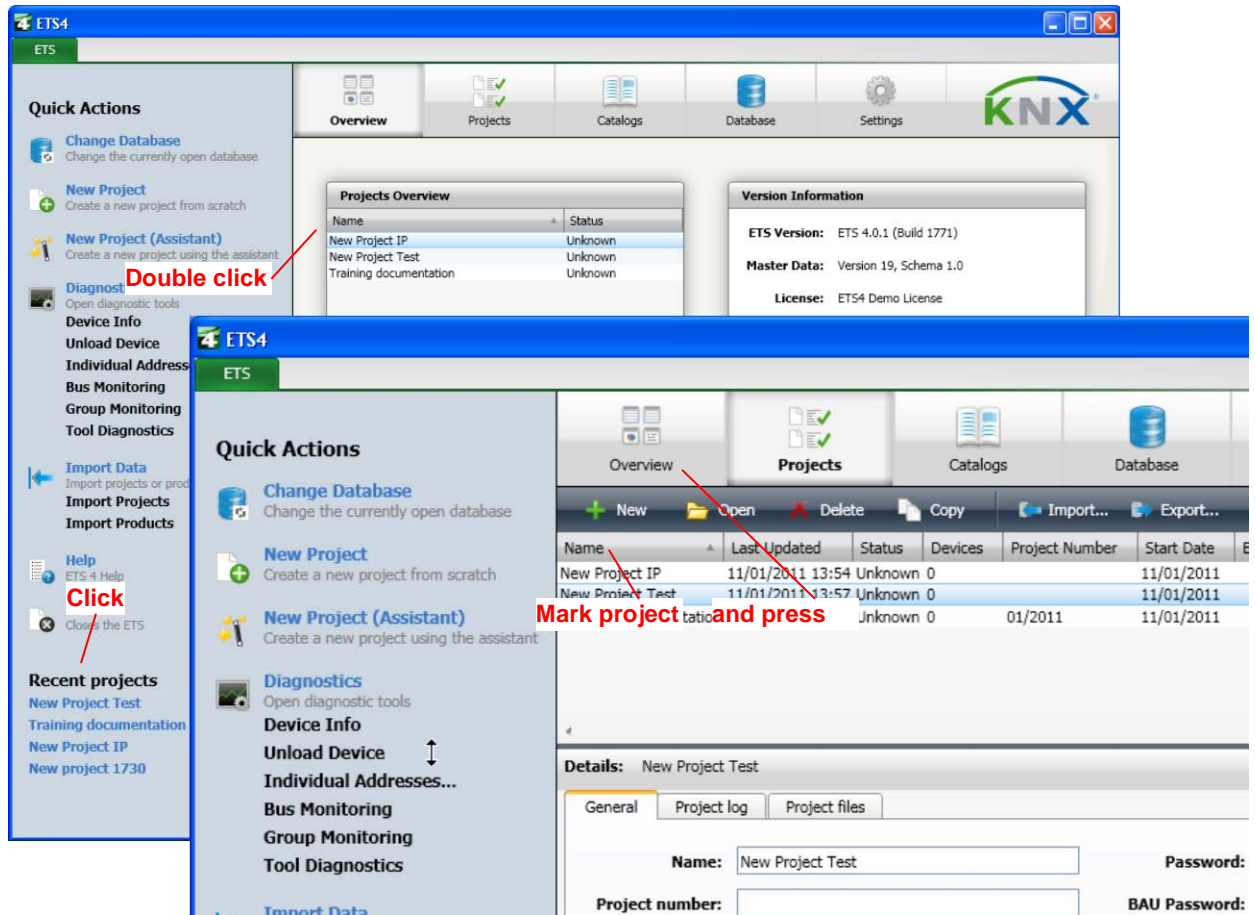
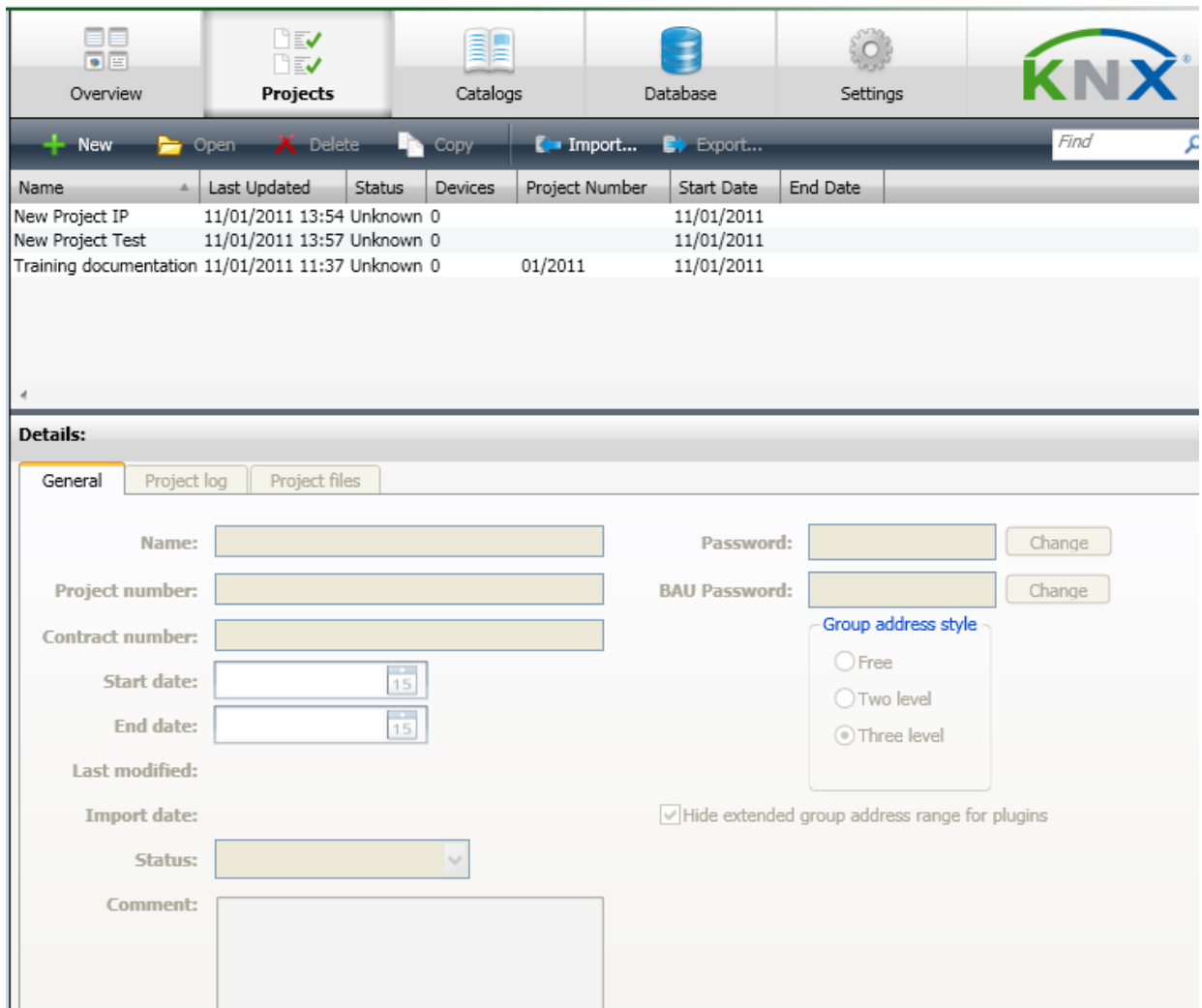

Figure 14: Opening an existing project

## 2.2 Opening existing projects

From the dashboard, there are several options to open a project:

- Clicking on a project under *Recent projects* in the “Quick Actions” bar.
- Overview* tab: Double click on a project in the *Projects Overview* container.
- Projects* tab: Open the project marked in the list via the button.



Name	Last Updated	Status	Devices	Project Number	Start Date	End Date
New Project IP	11/01/2011 13:54	Unknown	0		11/01/2011	
New Project Test	11/01/2011 13:57	Unknown	0		11/01/2011	
Training documentation	11/01/2011 11:37	Unknown	0	01/2011	11/01/2011	

Figure 15: Project details

## 2.3 Project details

In the *Projects* tab on the dashboard, you can see the details of the project marked in the list. The details are given in three index cards that can be selected via tabs.

### 2.3.1 General index card

On this index card, you can change the name of the project and there are further fields for specifying the project.

You define here which group address view should be used for this project and you can assign a project password and a BCU password for BCUs supporting this feature. With a project password, a project can be protected against unauthorised access. Each time the project is opened, the password is requested.

With the BCU password (BCU=bus coupling unit), BCUs supporting this feature can be protected against unauthorised tampering. The entered BCU password is applies to all BCUs within this project.

The BCU password consists of 8 hexadecimal digits (possible values 0 to F).

**Caution:** If you forget the project password, it is no longer possible to access the project as the password is encrypted in the database.

### 2.3.2 Project log index card

This index card is used to structure, check and evaluate the project history. With the help of the *Add* button, the project history can be extended. You need to mark the corresponding line in order to modify an entry or to see the exact description. The entry can then be edited.

### 2.3.3 Project files index card

Under *Project files*, you can add other files to the project, which should be saved together with this project in the database. They can be e.g. Word or Excel files or files with drawings.

## 2.4 Project design views

When you open up a project, you access the project design view of ETS. The following screenshot shows the elements of this view.

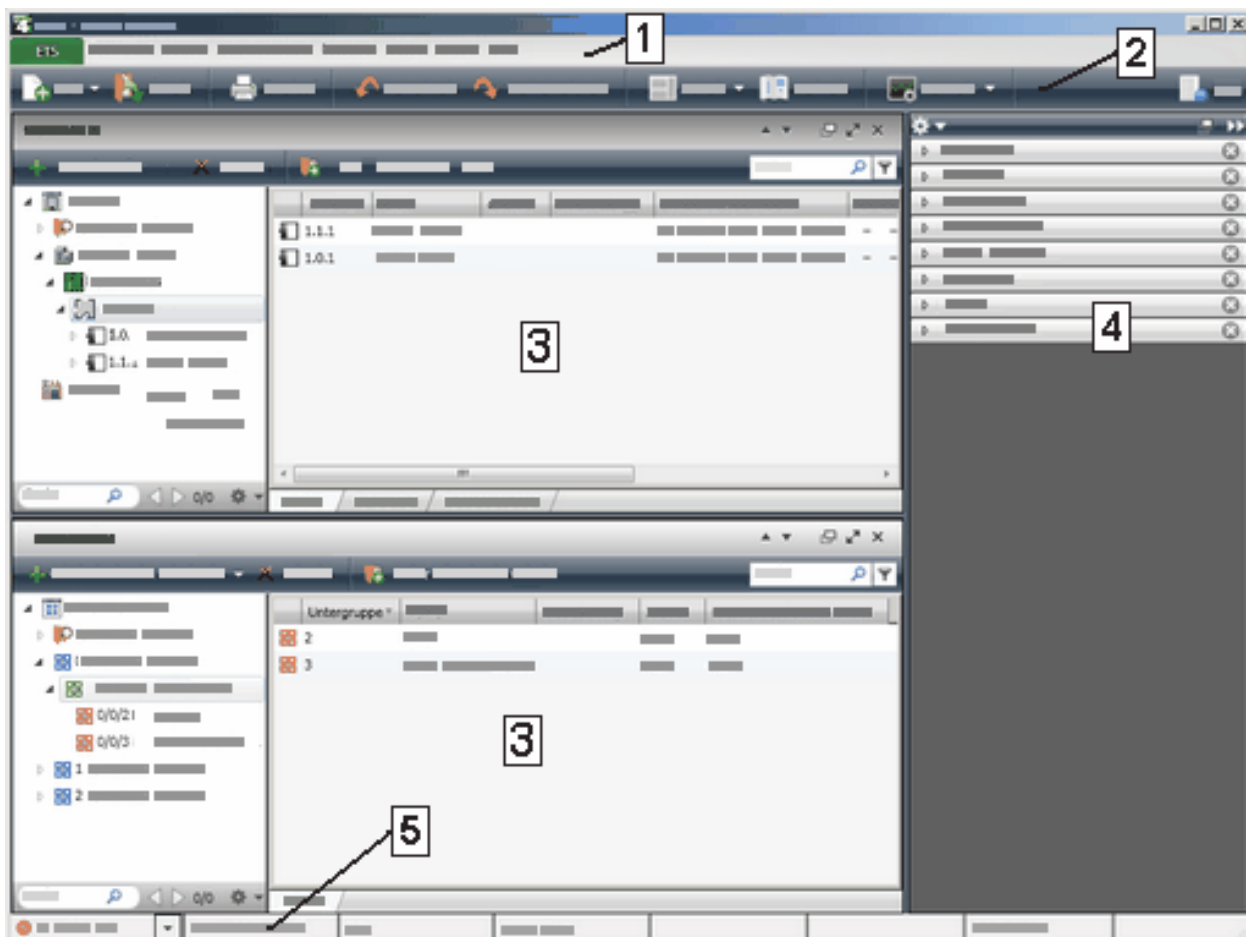

**Figure 16: Project design view**

The numbers in the screenshot designate the following elements:

- 1: Menu bar
- 2: Toolbar
- 3: Panels
- 4: Navigation bar (side bar)
- 5: Status bar

To a large extent, the project design of a KNX installation is done in the panels. They can be used simultaneously. Panels can be arranged according to the editing process. The following panels are available:

- ✚ Buildings,
  - ✚ Group Addresses,
  - ✚ Topology,
  - ✚ Project Root,
  - ✚ Devices,
  - ✚ Catalogs
- and as a special case
- ✚ Side Bar

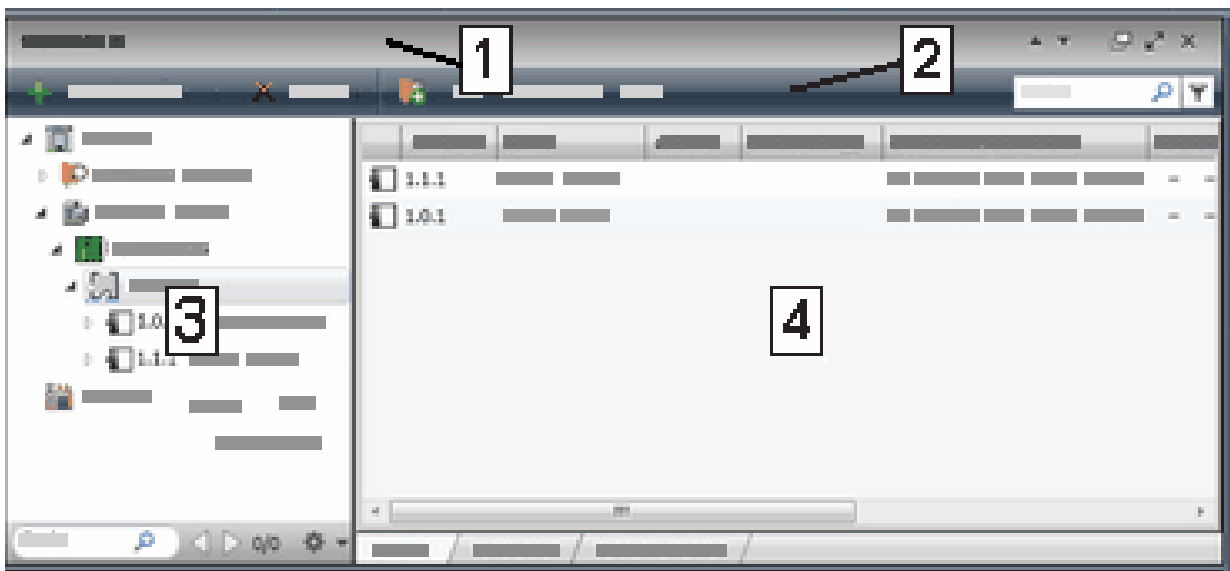

**Figure 17: Panels**

Elements of the panels are:

- 1: Title bar. By clicking on the title, you can select which panel should be displayed.
- 2: Toolbar. The tools available depend on the respective panel (context-sensitive)
3. Tree view
- 4: List view. The list view can have up to three index cards which you can select via the tabs below.

Further panels can be opened via the toolbar: *View / Open New Panel*.

Projects can be ordered according to building, function or bus structure hierarchies. One uses the Buildings and the Topology view to structure one's project more clearly.

A combination of panels and their exact appearance can be saved as a *Workspace*. You select the workspaces via the *Workspaces* container in the side bar. Further information about the creation and storage of workspaces is described in the section on complex project design.

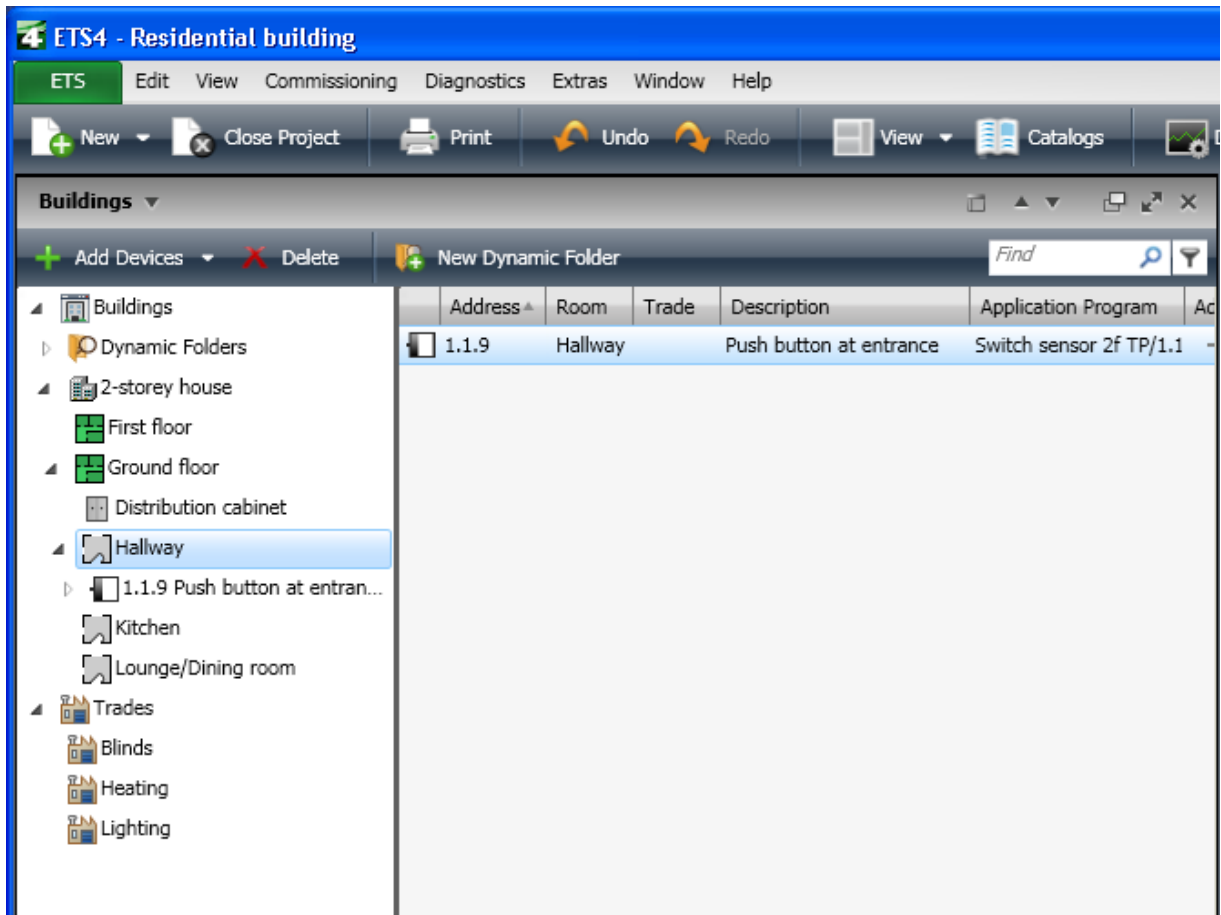

**Figure 18: Buildings window**

### 2.4.1 Buildings window

The Buildings view is the central view of ETS. The Buildings view is used to structure the KNX projects according to the actual building structure and to insert the KNX devices. The following elements are available to structure the building:

- ✚ Buildings,
- ✚ Building parts,
- ✚ Floors,
- ✚ Corridors,
- ✚ Stairways,
- ✚ Rooms and
- ✚ Cabinets

The buildings, building parts and floors are only used for structuring and cannot directly contain devices.

Devices can be inserted in rooms, corridors, stairways or cabinets.

A hierarchical view is very useful for maintaining an overview in the case of large projects.

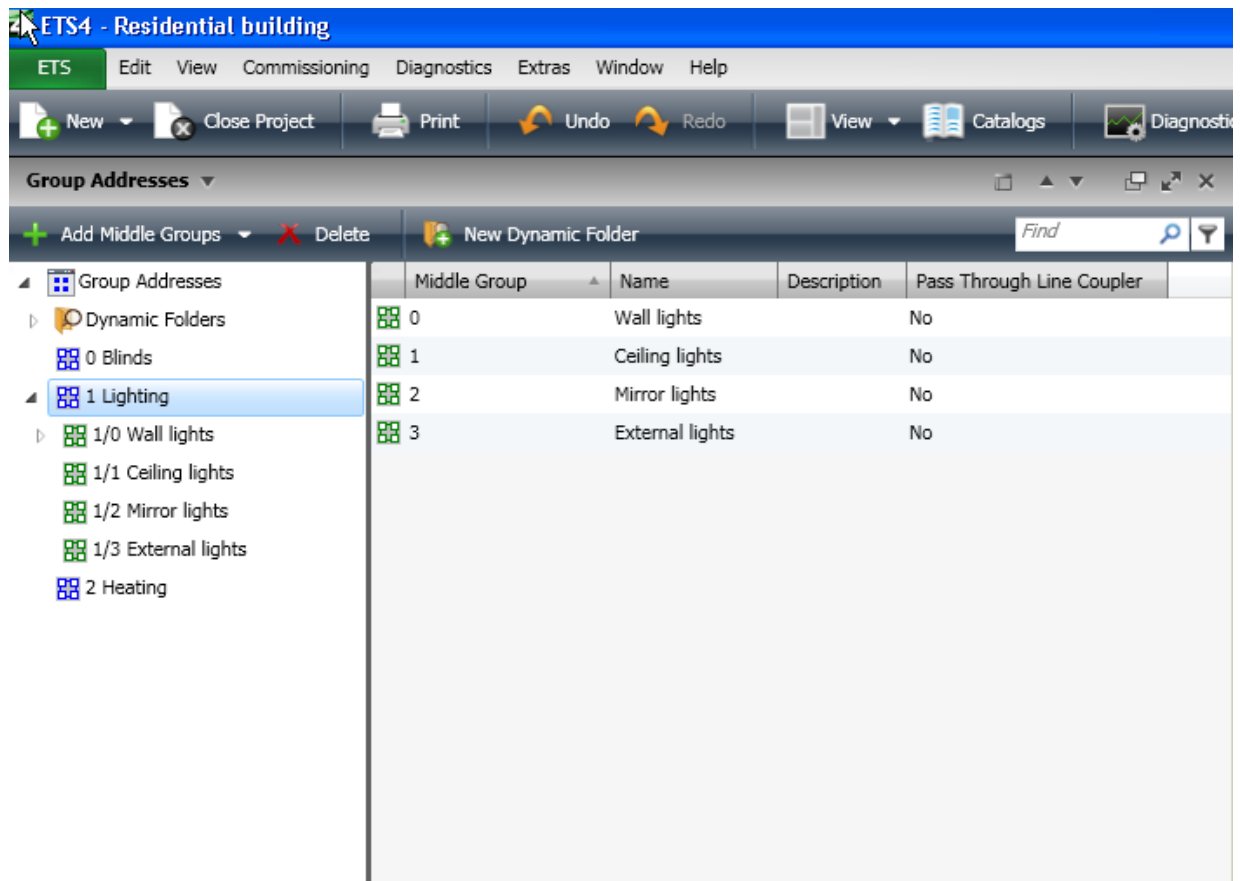

**Figure 19: Group Addresses window**

### 2.4.2 Group Addresses window

The Group Addresses window is used to generate and define group addresses. This view is required together with the Building view to link the group addresses to the corresponding group objects. The group addresses in the *Group Addresses* window are represented in a two-level, three-level or free style, depending on the preset option.

The representation of the group addresses in different levels has no functional effect. It only enhances lucidity. The 3-level structure is used in this documentation. If you select a subgroup, the group objects that have been assigned to the group address are displayed in the right-hand list view.

The tree view (left-hand side) displays the available group addresses (in this case group addresses on three levels).

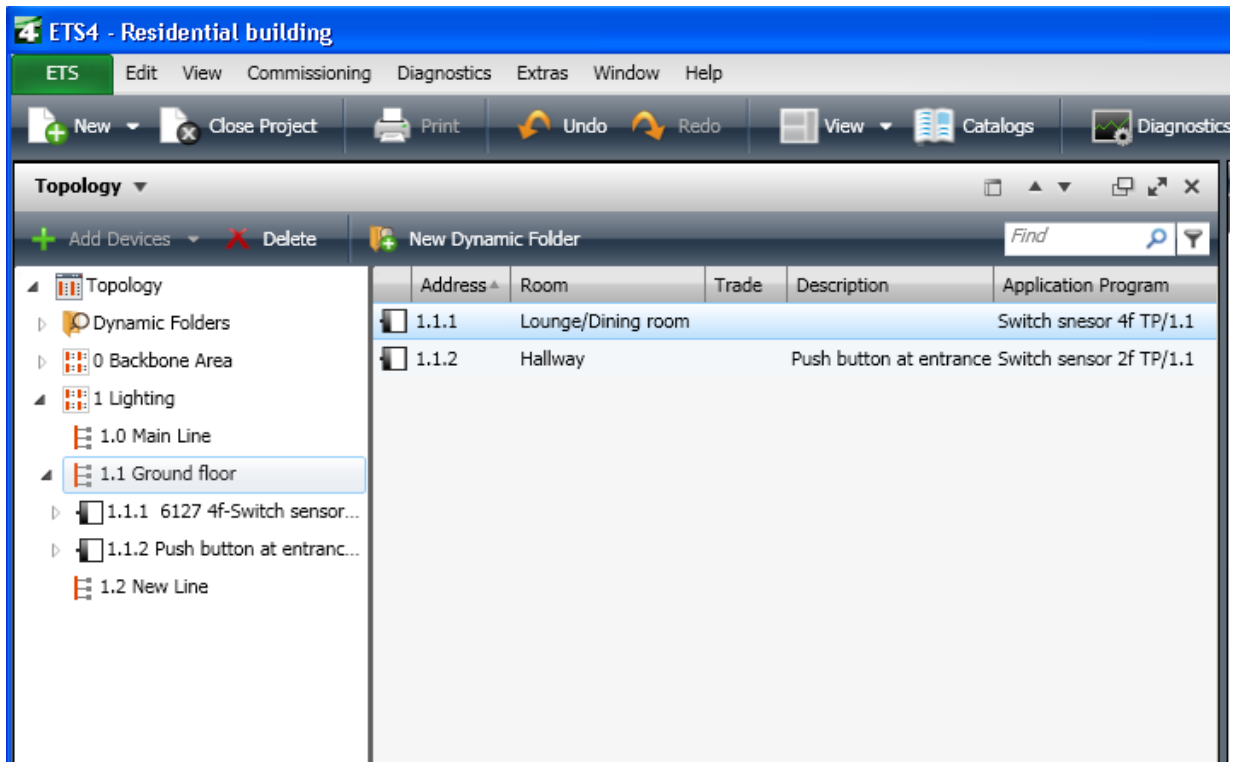

Figure 20: Topology window

### 2.4.3 Topology window

The Topology window is used to define the actual bus structure and the assignment of individual addresses to the devices. This view can be used simultaneously with other views and displays the KNX project as regards bus structure. The view shows the devices as they are assigned to the different lines. Twisted Pair, Powerline and IP lines and areas are represented with different symbols.

The tree view (left-hand side) shows the existing bus topology of the KNX project while the right-hand side displays a list view of the elements marked in the left-hand window.

The structure of the topology is normally generated automatically when individual addresses are assigned elsewhere. All higher-order elements such as areas and main lines are inserted according to the assigned addresses.

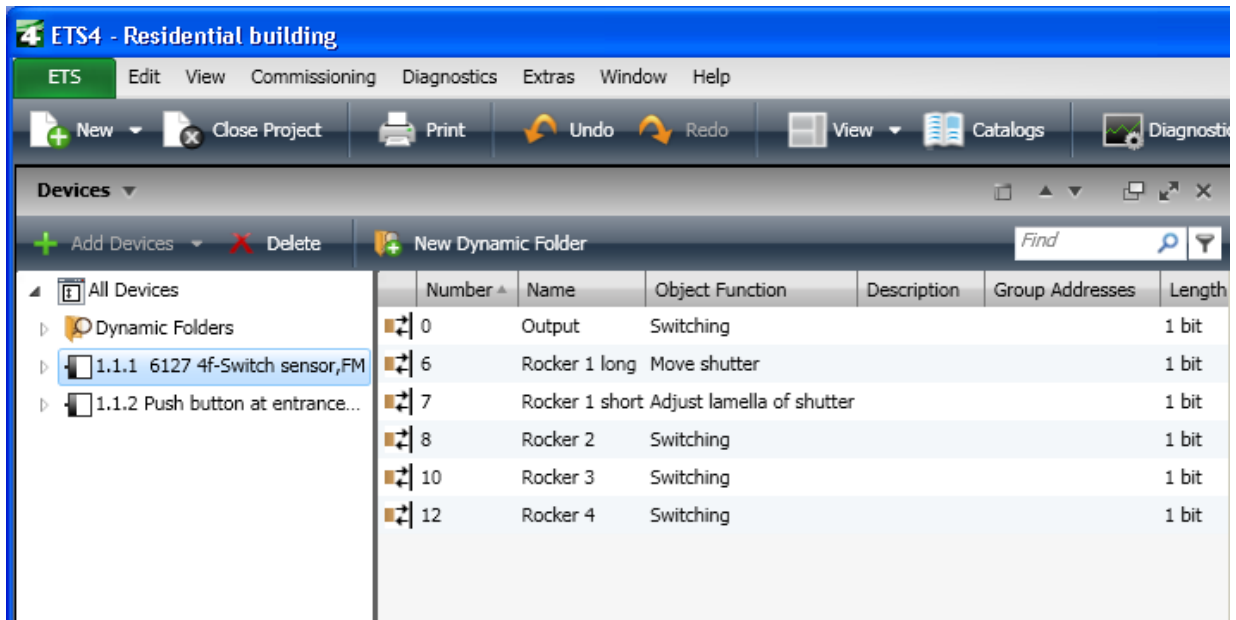

Figure 21: Devices view

#### 2.4.4 Devices window

**All** devices of your project are displayed in the *Devices* window, including those that have not yet been assigned to a room, function or line. As a result, you can often gain a good overview of your project, for example whether there are devices without an assigned individual address.

This list can be very large. It can therefore be very useful to set a filter. Further information on filters is explained in the section on complex project design.

With the devices displayed in this window, you can carry out all the tasks that can also be performed in the *Buildings* window or *Topology* window: editing devices, editing objects etc.

#### 2.4.5 Project Root window and Catalogs window

The *Project Root* window combines together the *Buildings*, *Group Addresses*, *Topology* and *All Devices* windows in one window.

One often opens the *Catalogs* window indirectly when inserting devices in the *Buildings* window or in the *Topology* window.

#### 2.4.6 Side Bar

The *Side Bar* bundles functions and information one frequently requires during project design and commissioning.

The side bar is always displayed, except in conjunction with the dashboard. It is located on the right-hand or left-hand side of the screen and can be selected via the menu function *Workplace / Side Bar /...*. On the dashboard under *Settings / View*, you can select whether only one container is open in the side bar or several simultaneously.



### 3 Quick project design with ETS

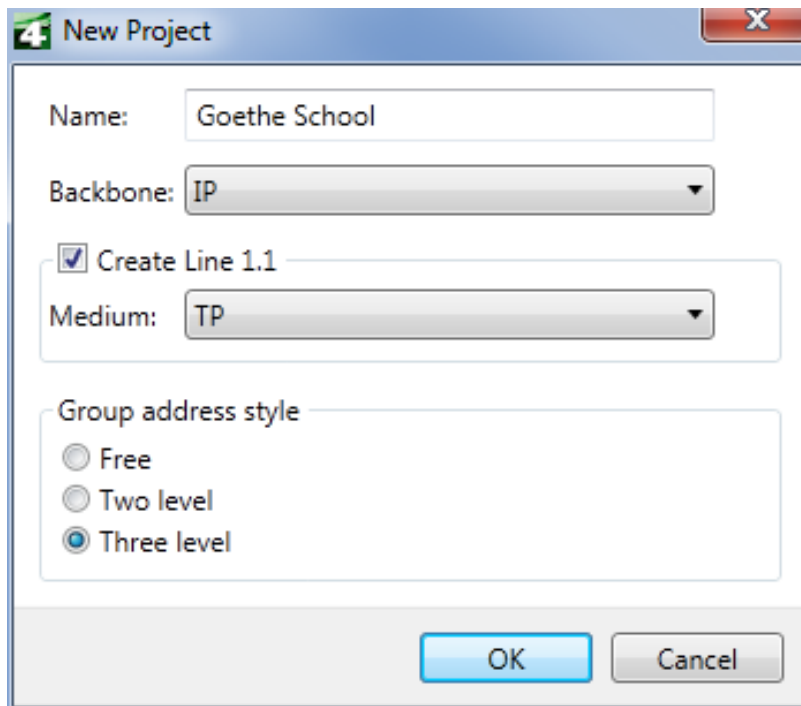

Figure 22: Creating a new project

#### 3.1 Starting the project design

On the basis of this example, the project design of small KNX projects is explained.

The project *Goethe School* is an example of a “quick project design”.

The *New Project* window has been opened on the dashboard via the “Quick Actions” bar.

The project name must be entered in the *Name*: field (in this case: *Goethe School*). The Group Addresses view is set to three levels (main group / middle group / subgroup).

Pressing the *OK* button after entering the name opens the new project (with two panels *Topology* and *Group Addresses*, provided that the *Default* workspace is set in the side bar).

For practical reasons, you should change the *Topology* panel to the *Buildings* panel by clicking on *Topology* in the title bar of the window and then selecting *Buildings*. You thus have two relatively large *Buildings* and *Group Addresses* panels to work in.

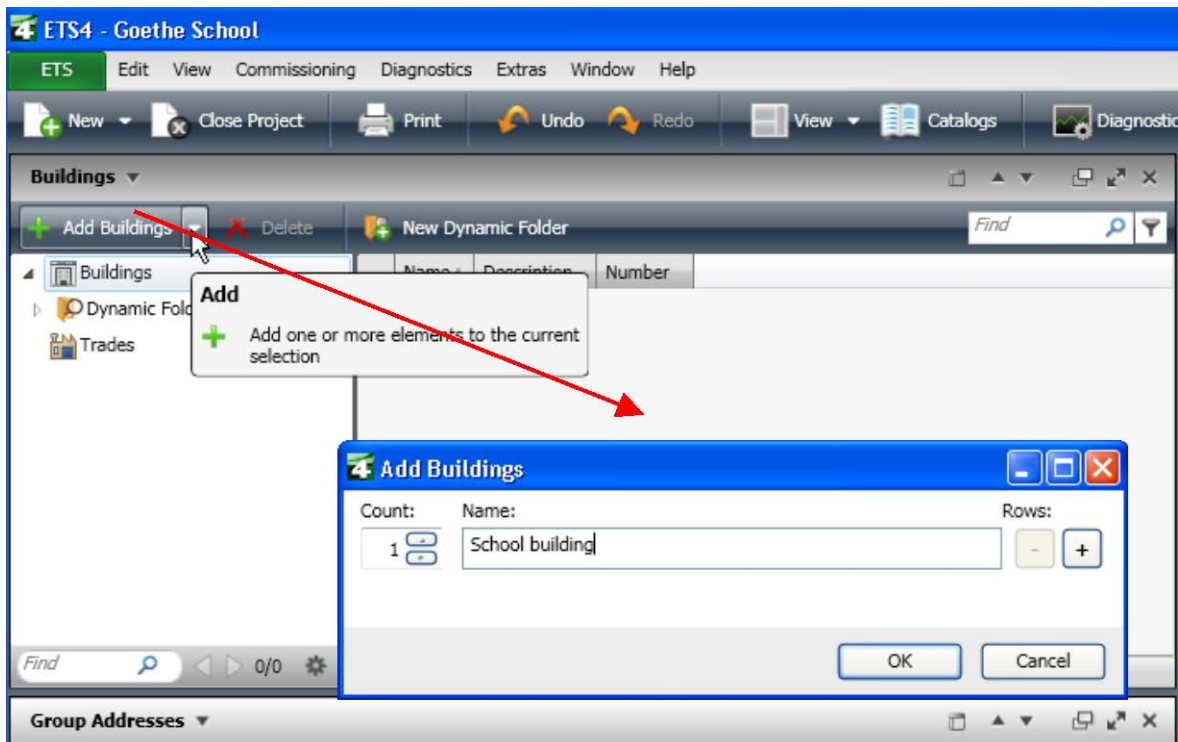



Figure 23: Creating a building structure

### 3.2 Creating a building structure

In the *Buildings* window, devices can only be inserted in rooms, corridors, stairways or cabinets. Hence, a minimum building structure must be created first. You must proceed in the following way:

1. Select *Buildings* in the *Buildings* window in the left half (tree structure).
2. Click on the symbol  in the toolbar. A window opens in which you can enter the name of the new building. If you do not enter a name, the building is designated as *New building* by ETS. This building should be given an appropriate name, in order to maintain the overview of one's project.
3. You can rename this building at any time. To do so, double click on the corresponding building in the tree structure. The *Properties* container of the building opens in the side bar, provided it is not already open. You can now enter a new name for the building in the *Name* field.

You can now introduce building parts and floors into the building as system structures. However, to keep this example as simple as possible, we will only insert one room.

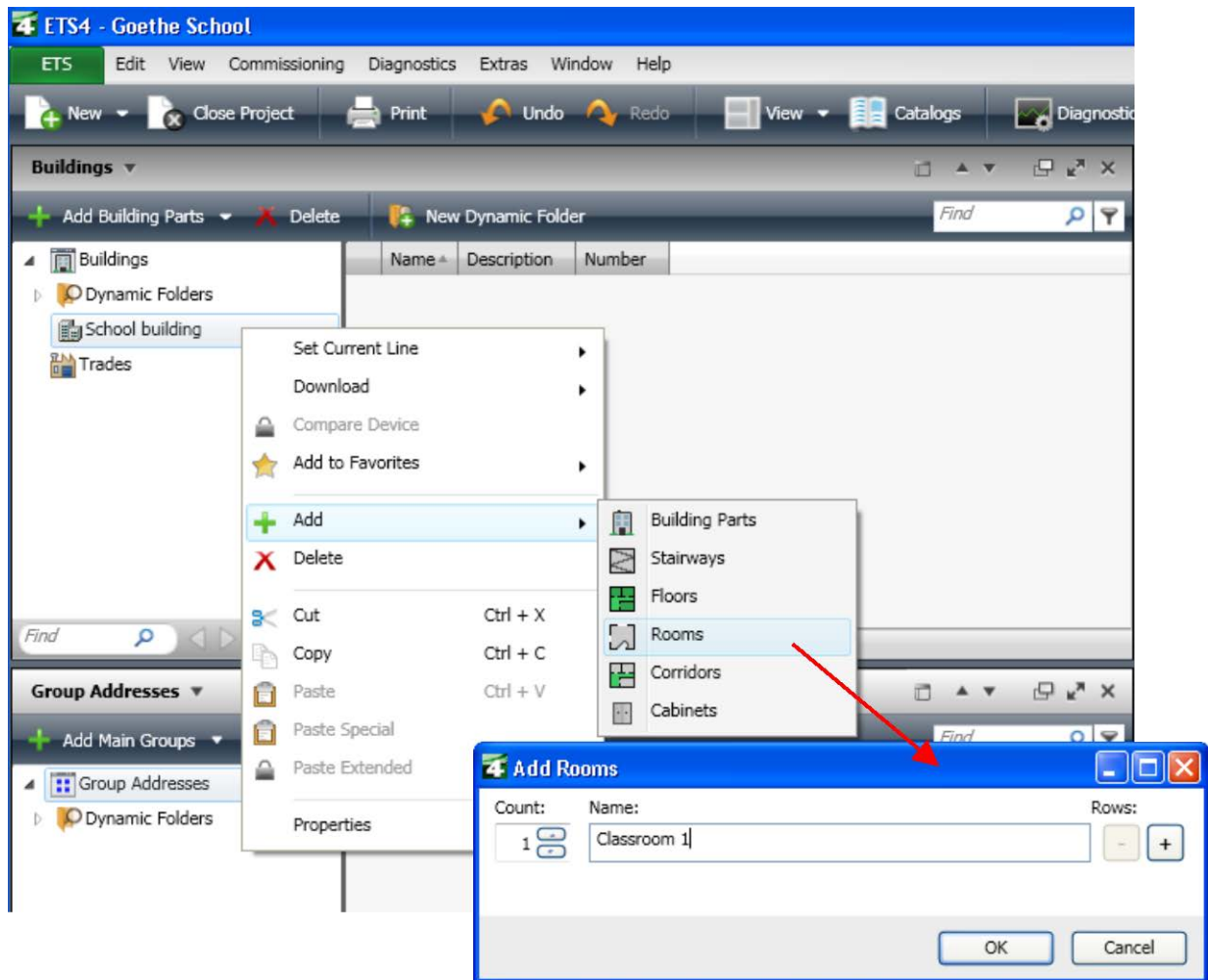

**Figure 24: Adding a room**

This can be done e.g. via the right mouse button function *Add/Rooms*. This opens the dialog *Add Rooms*, where you can immediately give the room a useful name. Further rooms as well as corridors, stairways or cabinets can now be added to the building. You can now also insert devices.

### 3.3 Product Finder

To insert devices, use the *Catalogs* window. Via the *Catalogs* window you can insert the device in the currently marked object. It may therefore be useful to select e.g. a room in the device window before opening the *Product Finder*. You can call up the *Catalogs*

window via the symbol  in the toolbar of the *Buildings* window. A further *Catalogs* window is opened.

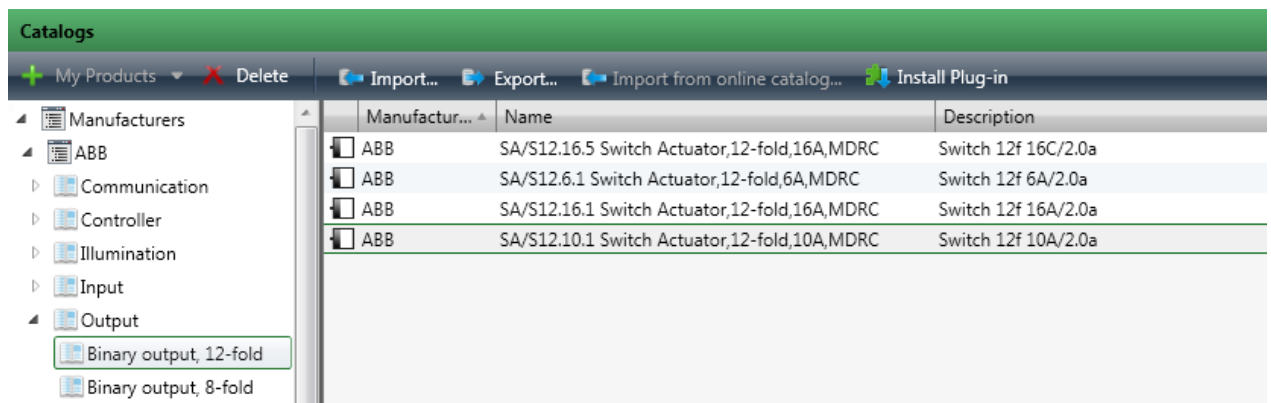

**Figure 25: Catalogs window**

### 3.3.1 Finding products

Various functions are available to select the required product/device. On the one hand, you can choose a manufacturer and a product group in the tree structure in the left half of the window: this will limit the number of devices displayed in the list view considerably. It is however also possible to limit the display in the list view with the search function or the filter function (both in the right-hand corner of the toolbar). The selection in the tree structure hereby overrides the search function and the filter function. The narrower the search selection, the fewer products are displayed.

### 3.3.2 Inserting devices

To insert a product with the corresponding application, select the product in the list view of the Catalogs window with the mouse. Then press the *Add* button (or double click on the product with the mouse). It is possible to insert in one go a device several times by entering the number of elements that are to be inserted.

The individual addresses are automatically assigned by ETS in ascending order in the respective current line. The topic 'current line' is rather complex. If required, consult the help feature of ETS for further information.

You can change the individual addresses at any time under the properties of the devices.

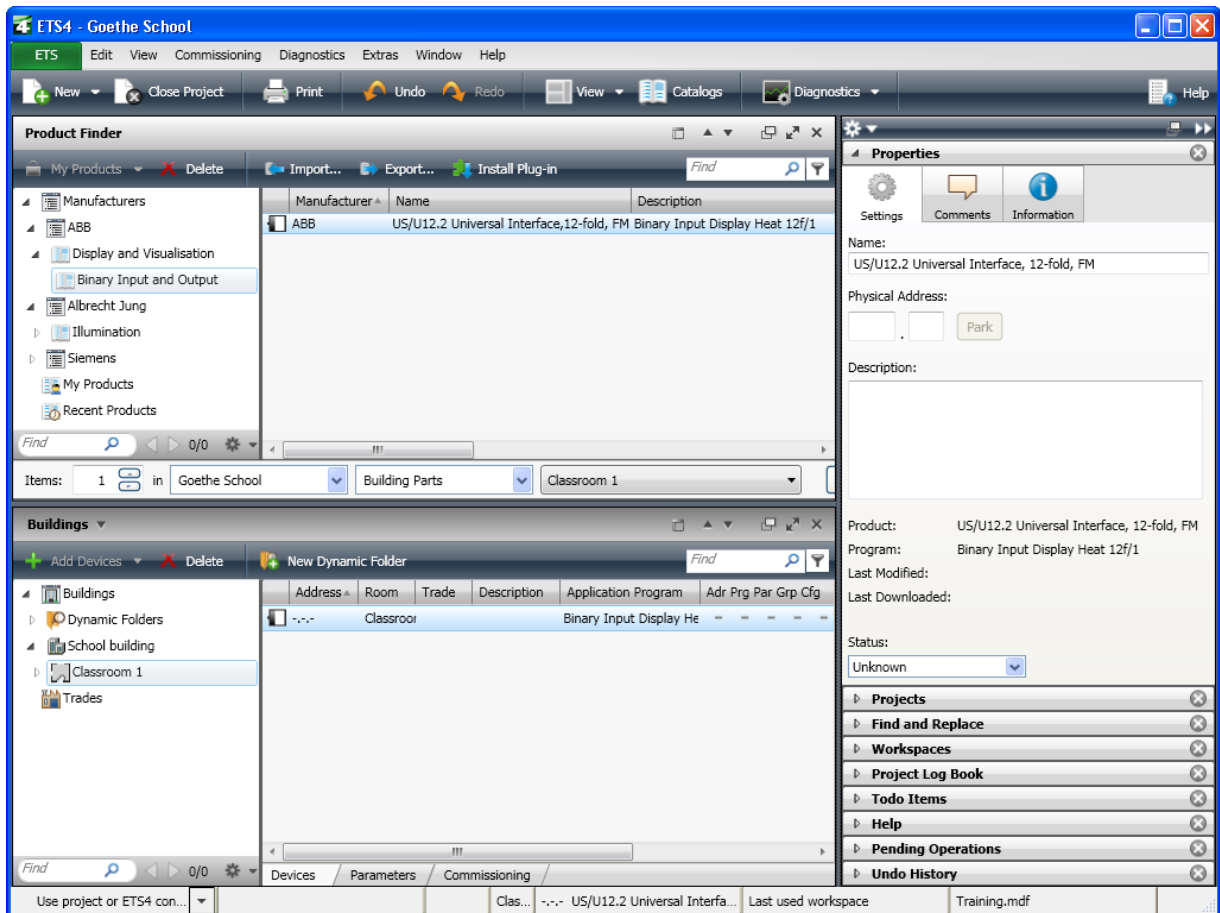

Figure 26: Properties container of the devices in the side bar

### 3.4 Properties of the devices

The inserted device is displayed in the list view if the associated room has been marked. It will also be shown in the tree structure of the Building view underneath the room. The *Properties* container in the side bar is opened by double clicking on the inserted device. This container has up to three index cards, which can be selected via tabs. Some index cards only contain information i.e. you cannot make any changes. The *Settings* card is the most important.

It is possible here to change the individual address of the device. A change in the “Individual address” field automatically assigns the device to another line and/or another area in the bus topology.

**Note:** Only free addresses can be assigned!

It is also possible to add comments about the device in the *Description* field. A description along the lines “what is the device, where is it installed and what is it used for” is good practice. Collating information here pays off later during commissioning and fault diagnosis.

#### 3.4.1 Product information

The *Properties* container of the devices contains further information about a product under the *Information* tab.

Here you can find information about the application of the device. It is also possible to change the application of a device in this container. There is also an index card with catalog information about the respective product.

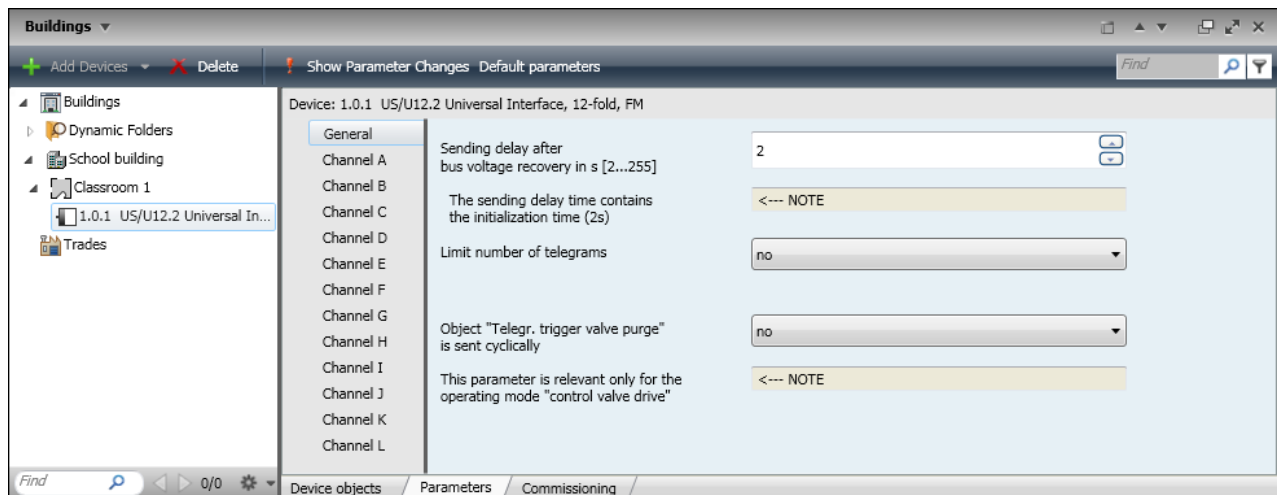

Figure 27: Device parameters

### 3.5 Device parameters

You access the device parameters via the *Parameters* tab at the bottom of the list view in the *Buildings* window. To do so, a device must of course be marked in the tree view in the left-hand side of the window. The device parameters can be set here. The parameters define the concrete function of the application program - e.g. in the above example, the sending delay after bus voltage recovery - can be specified.

The “Parameters” window is product-dependent. More detailed information about the individual parameters, application descriptions are available from the manufacturers. The parameters are divided into groups which are listed in the left-hand column of the parameter window. By selecting the individual groups in this list, you access the associated parameters in the right-hand side of the window.

The parameters can be reset to the original values as set by the manufacturers via the *Default parameters* button in the toolbar. The *Show Parameter Changes* button marks all parameters modified by the user with a red exclamation mark.

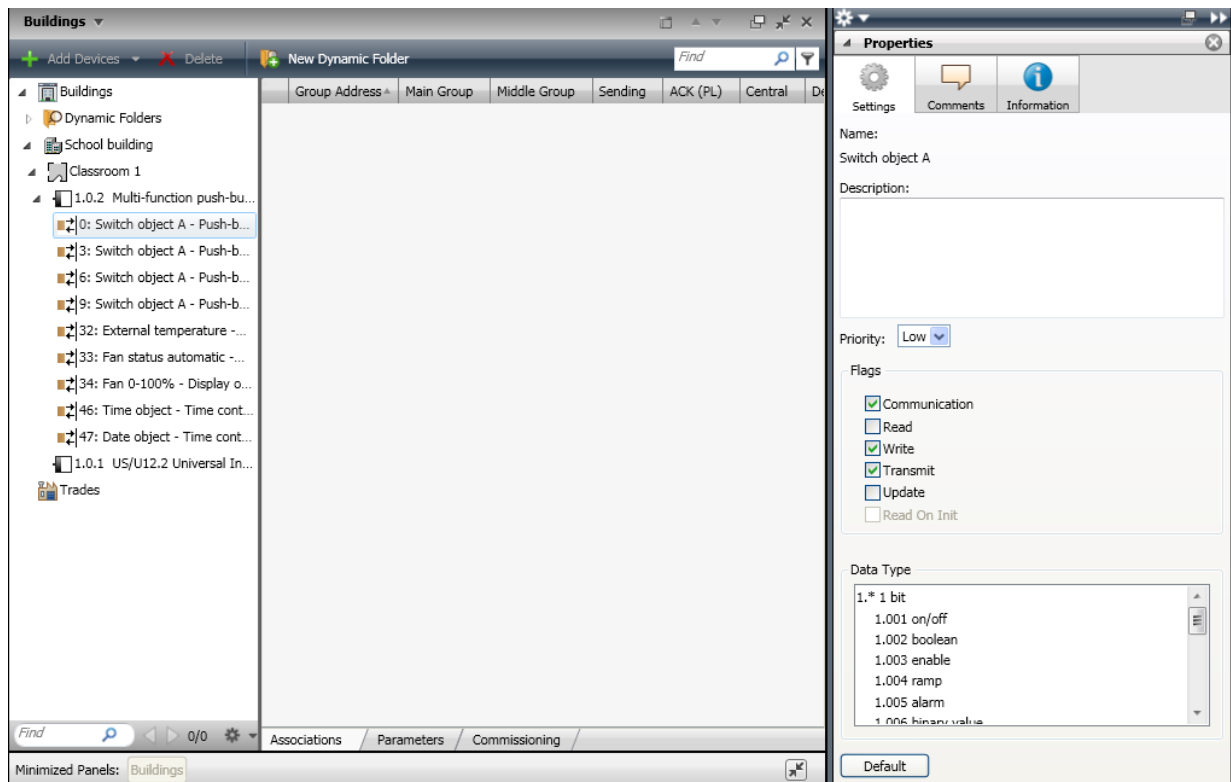

**Figure 28: Editing objects**



### 3.6 Editing group objects

The group objects of devices (further down referred to as 'objects') are displayed in the tree view (left half of the window) below the devices and in the list view (right half of the window) if you have marked a device in the tree view.

If you have marked an object in the tree view, you see under the "Associations" tab in the list view all group addresses that are assigned to this object. You can also make modifications e.g. you can delete the assignment to this object.

By double clicking on the individual objects in the list view or by marking an object in the tree view, you open the *Properties* container of the objects. The properties of the objects can be set here.

It is possible to change the default priority of the transmitted telegrams for group objects, as originally set by the manufacturer. The following priorities are possible:

-  **Low**      Low priority for non critical time functions
-  **High**     Normal priority for manual functions
-  **Alarm**    High priority for critical time functions

**Note:** The priority should only be changed in special cases.

The flag of the group objects can moreover be set here.

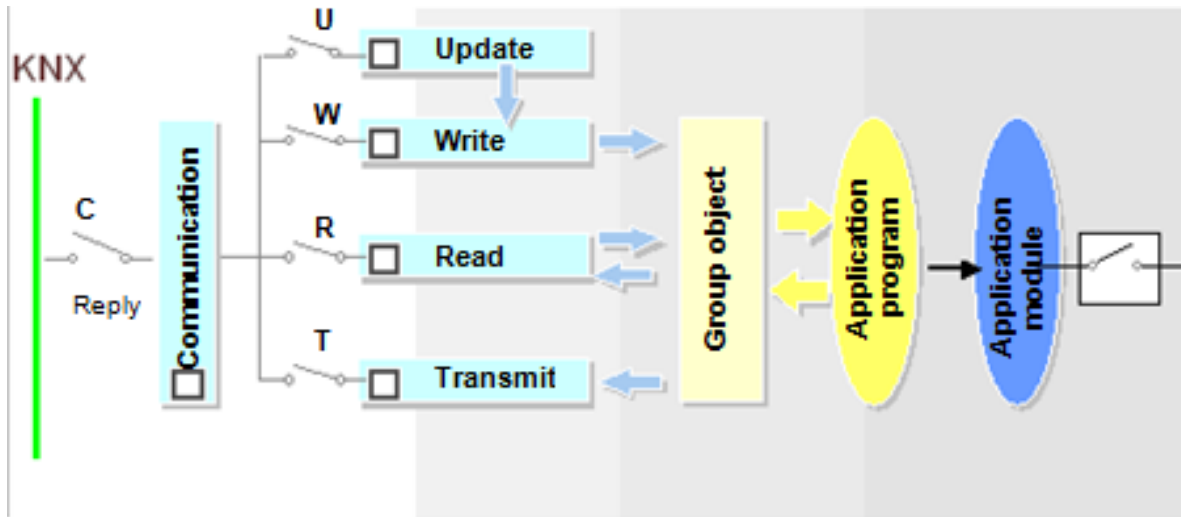

Caution: Telegrams are always confirmed even if communication has been deactivated

Figure 29: Representation of the flags

### 3.6.1 Setting the flags

The behaviour on the bus can be set for each group object with the help of the flags (data flow regulation).

Below you will find the 4 most important basic settings, depending on the object type:

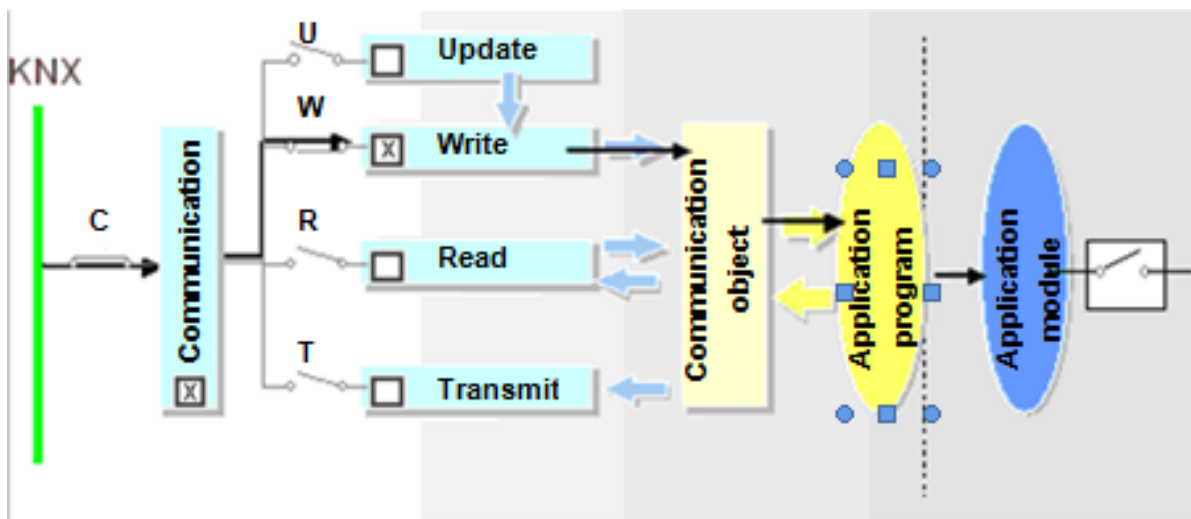

Minimum settings for actuator objects

Figure 30: Minimum settings of the flags for actuator objects



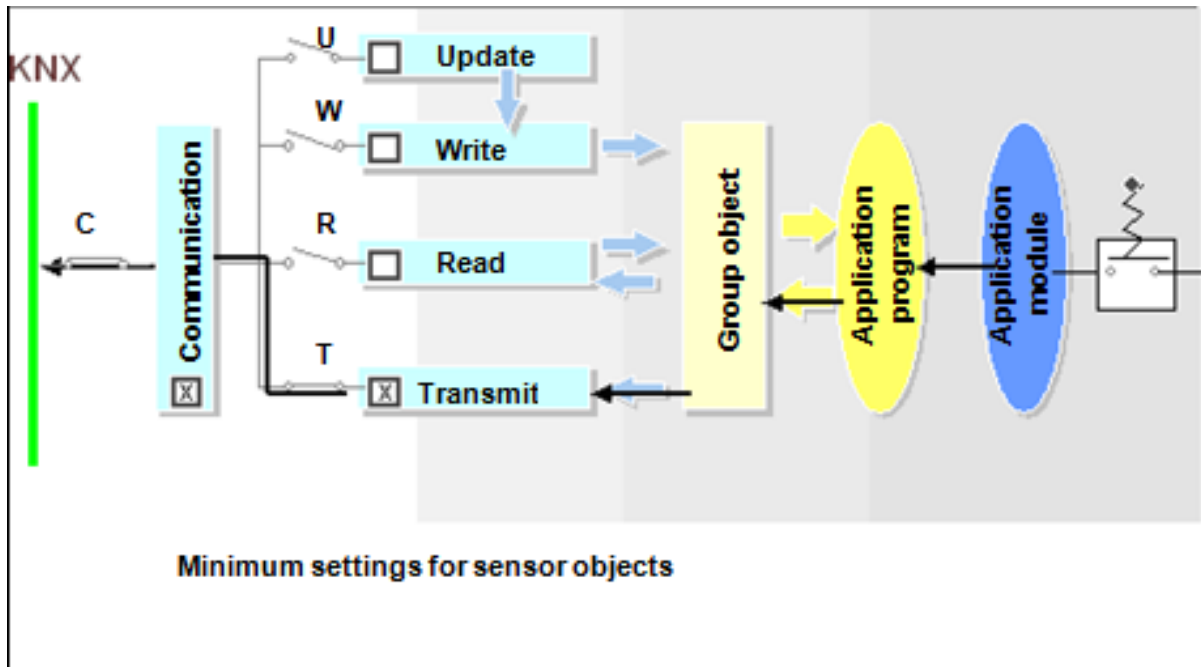

Figure 31: Minimum settings of the flags for sensor objects

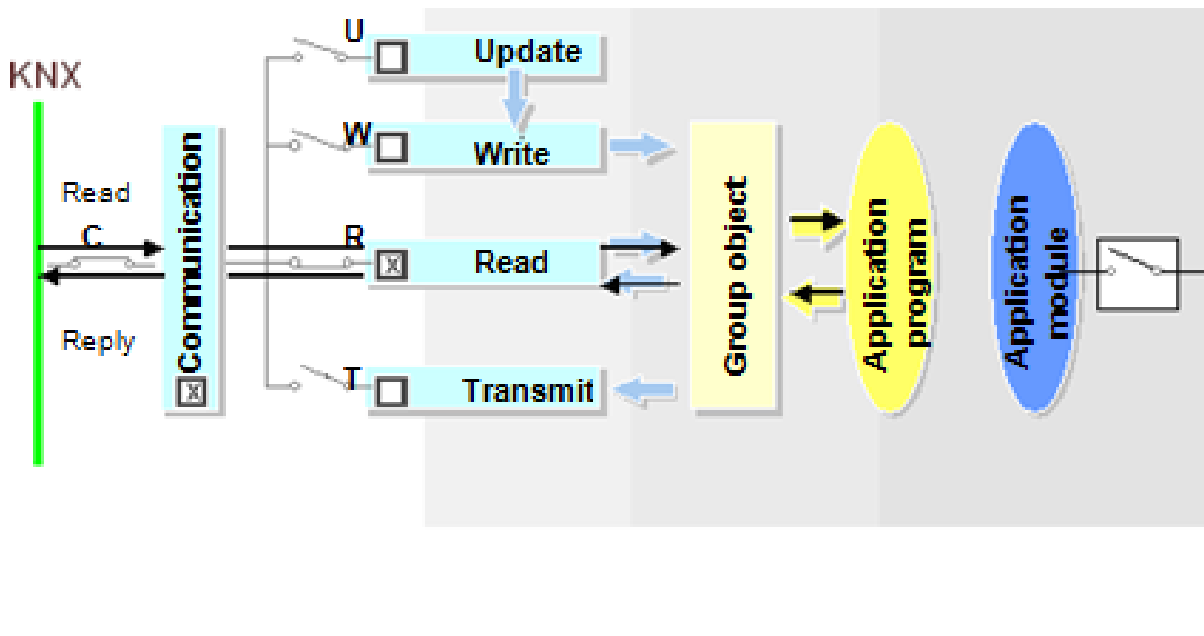
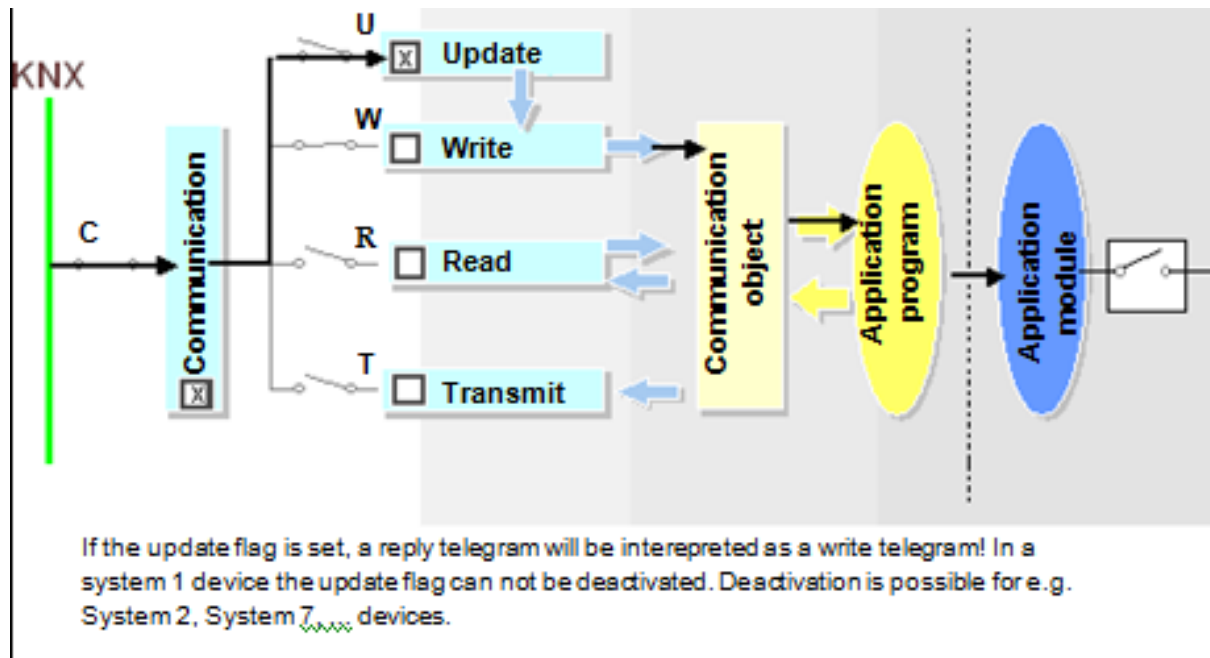
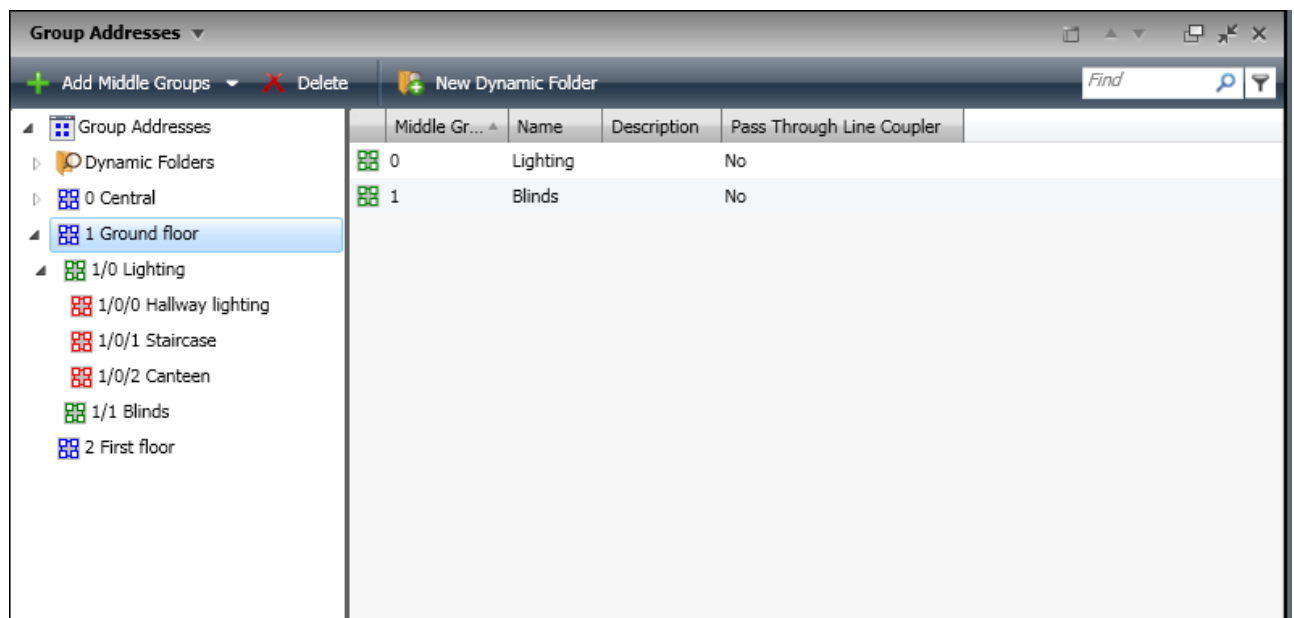

Figure 32: Minimum settings of the flags for status objects



**Figure 33: The update flag**

For certain masks (System B), it is also possible to set the “Read at Init” flag: if set, the group object will automatically send a Read Value telegram after voltage recovery to initialise the value of the group object.



**Figure 34: Configuring group addresses**

### 3.7 Configuring group addresses

In the case of KNX, devices that should perform a specific function together are “logically wired” via group addresses.

Group addresses can be divided into two or three levels or one can create one’s own structuring of group addresses.

In the two-level style, the group address consists of a main group (0 to 31) and a subgroup (0 to 2047).

In the three-level style, it consists of a main group (0 to 31), a middle group (0 to 7) and a subgroup (0 to 255).

The group address is specified by separating the levels by a “/” (slash) (e.g. 1/0/2).

The levels of the group addresses can be set on the dashboard in the *Projects* tab under *Details / General*.

It is advisable to use the structure of the group addresses as an organisational feature.

The group addresses are generated in the Group Addresses window.

The group address structure displayed in the screenshot (left window half of the Group Addresses window) is generated via the corresponding buttons of the toolbar in the same way as the building structure of the Buildings window.

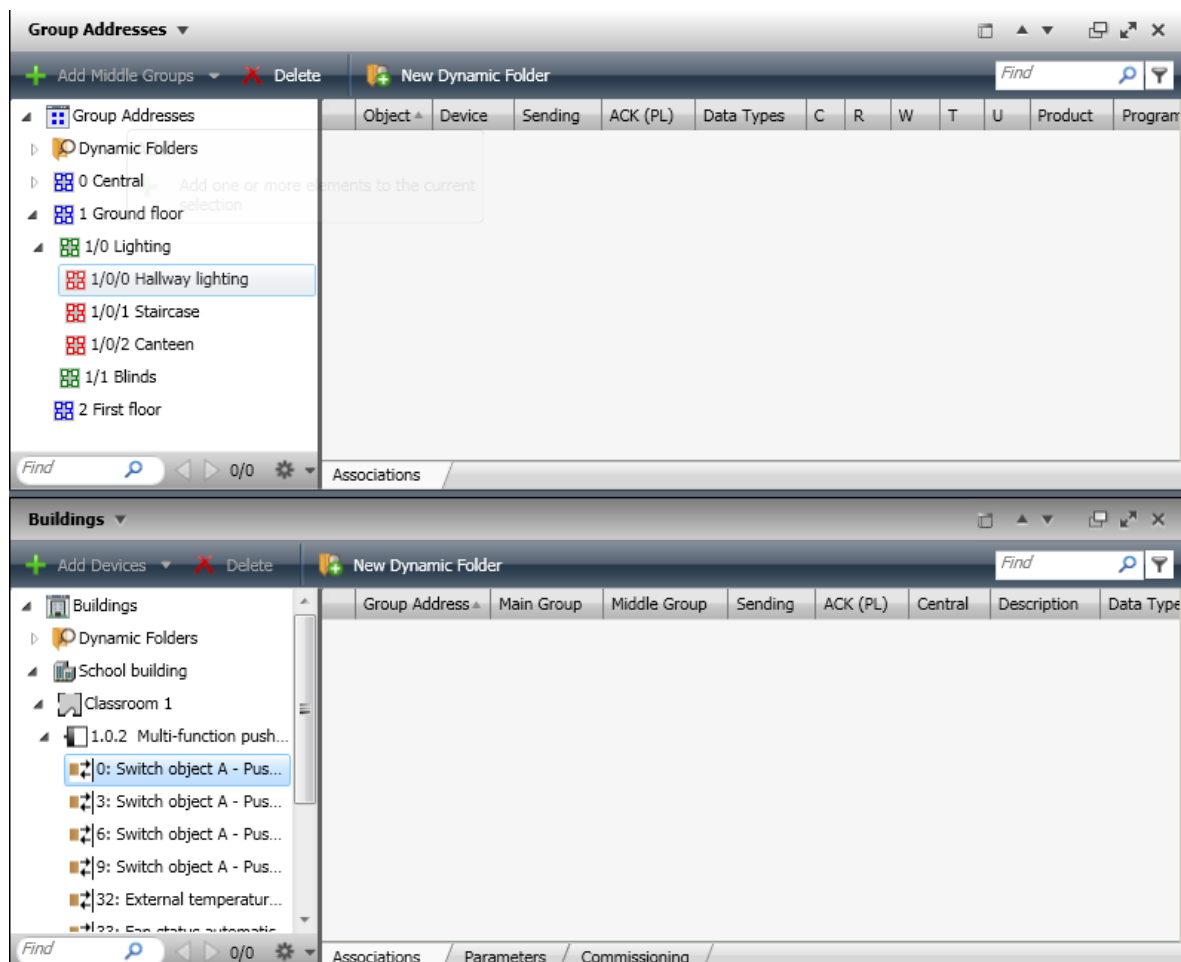

Figure 35: Assignment of group addresses

### 3.8 Assignment of group addresses

In order to ensure that sensors and actuators know which of their group objects should communicate with each other to realize a specific function, the group addresses must be assigned to the group objects. The group objects are linked logically with each other via the corresponding group addresses (“wired”).

In order to assign the group addresses to the objects, it is useful to have two panels open at the same time: the Group Addresses window and e.g. the Buildings window. There are several ways to assign group addresses.

The fastest method is via drag and drop:

You drag the required group address from the Group Addresses window onto the corresponding object in the Buildings window (or the object onto the corresponding group address) with the mouse – keeping the left mouse button held down – and then release it. In this way, group addresses are assigned to objects.

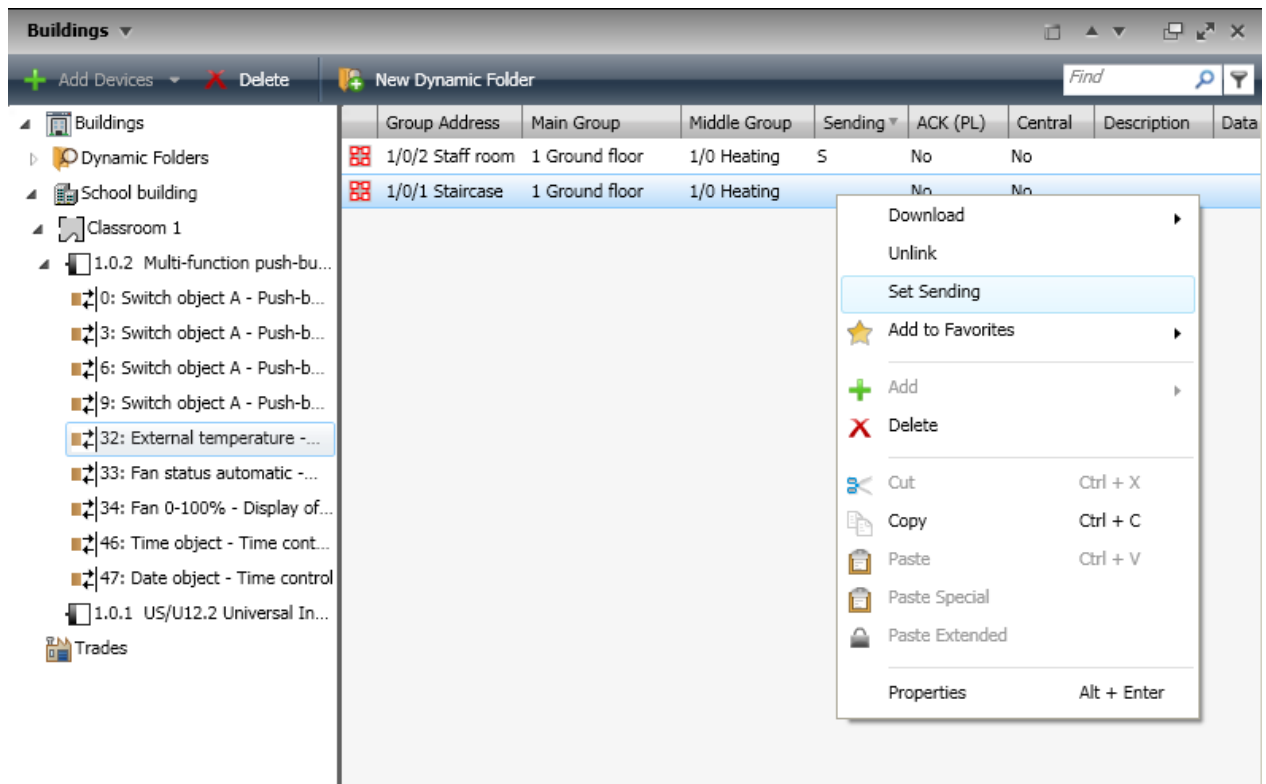

Figure 36: Sending group address

### 3.8.1 Sending group address

A group object may have multiple connections by assigning several group addresses. If the group object has the function of a sensor, then the first assigned group address is used as a target address in the telegram (sending group address). If you wish to modify which group address should be the sending group address, this can be done in the Buildings window via the right mouse button, i.e. in the list view (right window half) of the group objects.

**Note:** There are also sensors, permitting only one address per group object. The number of group addresses that can be assigned to a group object and the number of maximum associations (number of assignments per product) are product-dependent.

It is only possible to create connections with group addresses between group objects of the same type (1 bit, 4 bit, etc.). The group address receives the type of the group objects with the first assignment.

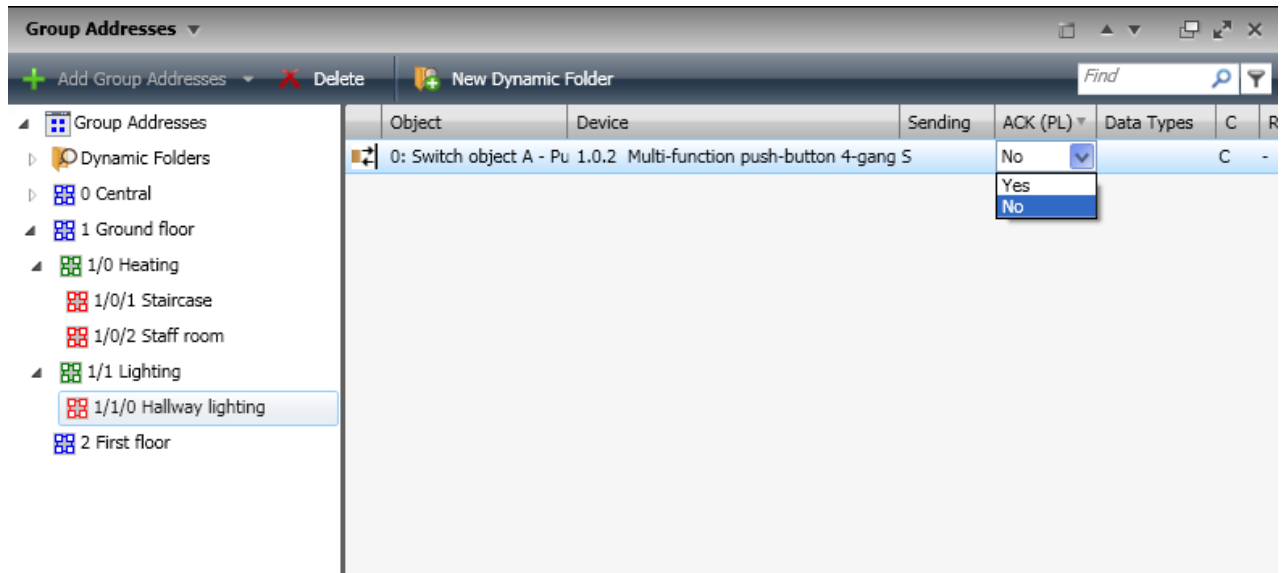

Figure 37: Group speaker flag

### 3.8.2 Group speaker flag

In the case of Powerline devices, the group speaker flag must be set for one object per group address. To do so, you select an object in the Group Address view and click in the list view on the field in the ACK column (PL). A pull-down menu then opens, in which you click on Yes, in order to set the group speaker flag for this object.

# KNX Project Design with ETS: Advanced

KNX Association

## Table of contents

1	Foreword.....	4
2	Workspaces, toolbars and Favorites .....	4
2.1	Which properties of the screen elements are stored in a workspace? .....	5
2.2	How can you now create your own workspaces? .....	5
2.3	Other modifiable properties that are not saved in workspaces: .....	6
3	Shortcut keys .....	8
4	Advanced topology.....	11
4.1	Structuring and planning reserves .....	11
4.2	Support from ETS when setting up larger size topologies: .....	12
4.2.1	Creating several areas .....	12
4.2.2	Creating several lines .....	13
4.2.3	Find and replace - Strategy .....	14
5	Different media (Powerline, TP, IP).....	14
6	Interlinked building structures .....	16
6.1	Inserting devices, systematic descriptions.....	16
6.2	Examples of device descriptions: .....	18
7	Group addresses Advanced.....	18
7.1	Structure of the addresses .....	18
7.1.1	3-level address structure .....	19
7.2	Description format .....	20
7.3	Group address settings .....	21
7.4	Creating large numbers of group addresses .....	22
7.4.1	Directly in ETS:.....	22
7.4.2	Via export to / import from EXCEL:.....	24
7.4.3	Free address structure .....	25
8	Professional functions and tools.....	26
8.1	Copying with options .....	27
8.2	Undo function .....	30
8.3	Dynamic folders.....	31
8.4	Checking and editing filter tables, permitted group address ranges .....	32
8.4.1	Automatic filter table .....	33
8.4.3	Using a dummy application.....	34
9	Checking the project .....	36
9.1	Device check.....	36

9.2	Group address check .....	37
9.3	Topology check .....	37
9.4	Product information check .....	37
9.5	Limits of the ETS project check .....	37
10	Bus hierarchy .....	38
10.1	General considerations .....	38
10.2	Taking the building structure into account .....	38
10.3	Inclusion of customer requirements .....	39
10.4	Consideration of system limits, planning of reserves .....	39
10.5	Line coupler or IP router? .....	40
10.6	Data rates and cyclical processes .....	41
11	Planning a project: Example .....	42
11.1	Requirements / regulations (specification text) .....	42
11.2	Task definition .....	43
11.2.1	Parts list for solution 1: .....	43
11.2.2	Parts list for solution 2: .....	44
11.3	Determining the bus loads .....	45
11.3.1	Scenario 1: .....	45
11.3.2	Always set the line/backbone coupler to "filter"! .....	46
11.3.3	Scenario 2: .....	46
11.4	Summary of the bus load calculation .....	48
12	Administration functions, project documentation and archiving .....	48
12.1	Reports .....	48
12.2	Exporting group addresses .....	50
12.3	Export OPC .....	51
12.4	Data types .....	52
13	Database handling, project backup .....	53
13.1	General .....	53
13.2	Using one database per project .....	53
13.3	Creating regular backups .....	54
13.4	Master database and project reconstruction .....	54
13.5	Central database memory and master database .....	55
14	Complete project documentation .....	55
14.1	Guidelines according to the German contracting procedure for building works (VOB) 56	
14.1.1	Contents of the project documentation .....	57
14.1.2	Handover to the client .....	58
14.1.3	Duties / behaviour of the contractor after handing over the project .....	59



## Advanced project design with ETS

**NOTE:** THIS CHAPTER IS INTENDED TO BE USED IN UPGRADE COURSES OR AS INFORMATIVE ANNEX TO BASIC COURSES. THE CONTENTS IS NOT PART OF THE EXAM AT THE END OF THE BASIC COURSE. ALL SUBSEQUENT SECTIONS REFER TO VERSION 4 OF ETS (ENGINEERING TOOL SOFTWARE).

### 1 Foreword

The intention of this chapter is to show the advanced user of the KNX system the possibilities of working even quicker with the “ETS” tool. It moreover contains important advice about preliminary considerations during the planning stage and deals with the responsibilities of a project engineer as regards documentation.

### 2 Workspaces, toolbars and Favorites

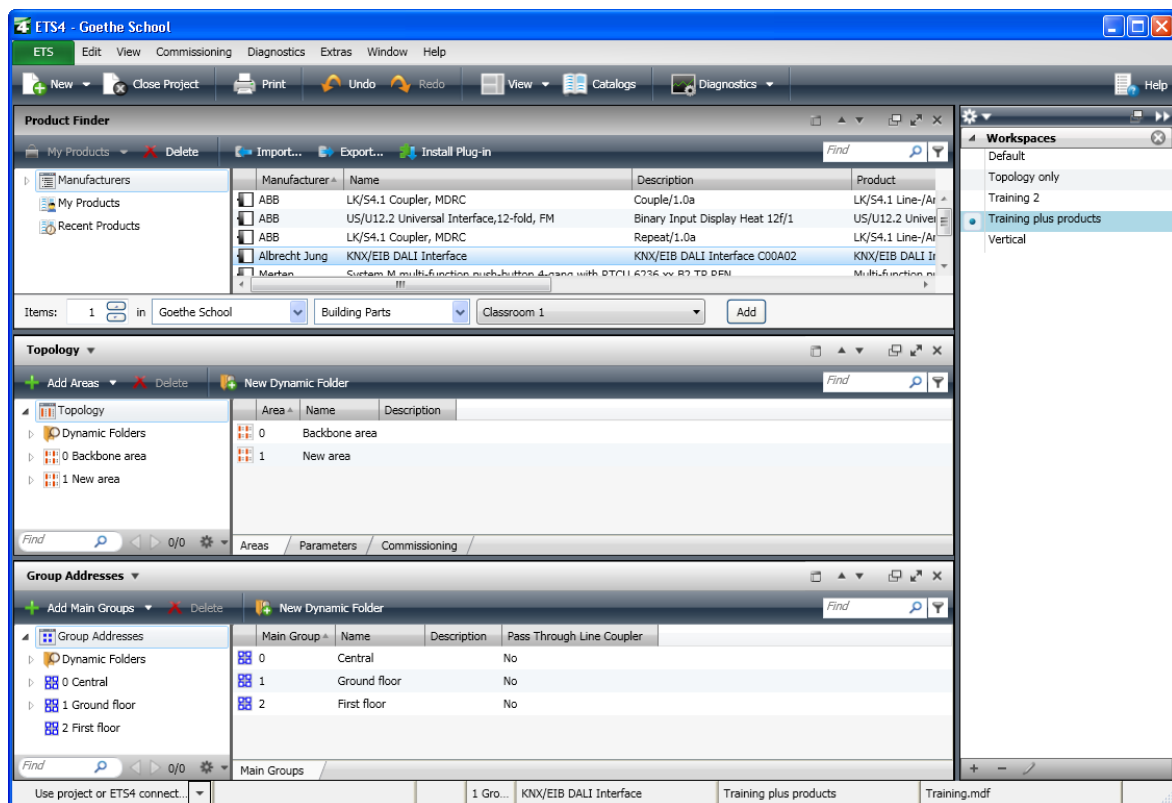

**Figure 1: Example of a workspace**

ETS enables you to create so-called workspaces. One is already “supplied” and is available when installing the software (called “Default” or “Standard”). A workspace is a project-independent, user interface template. You can achieve the following with the help of workspaces: each project designer will only see the information on his screen that he needs for his work. All unnecessary data is not displayed. The various views (e.g. building structure, topology, group addresses) as well as their structure and lists are arranged according to your personal needs.

The same project can look completely different when using different workspaces. A project designer needs different information compared to someone who is merely doing commissioning. The concept of workspaces takes these differences into account.

## 2.1 Which properties of the screen elements are stored in a workspace?

- ✚ All open windows e.g. Topology, Group Addresses, Building View
- ✚ The position and size of these windows
- ✚ The internal columns and structure of areas
- ✚ The visible columns and their layout (sequence)

## 2.2 How can you now create your own workspaces?

This is extremely simple: As soon as you have found the desired placement of screen elements (number / type / size / layout of the windows, number of columns, order, content), you open the “Workspaces” (1) box in the side bar. You click on the “plus” symbol (2) in the footer and then assign a useful name (3) to this workspace.

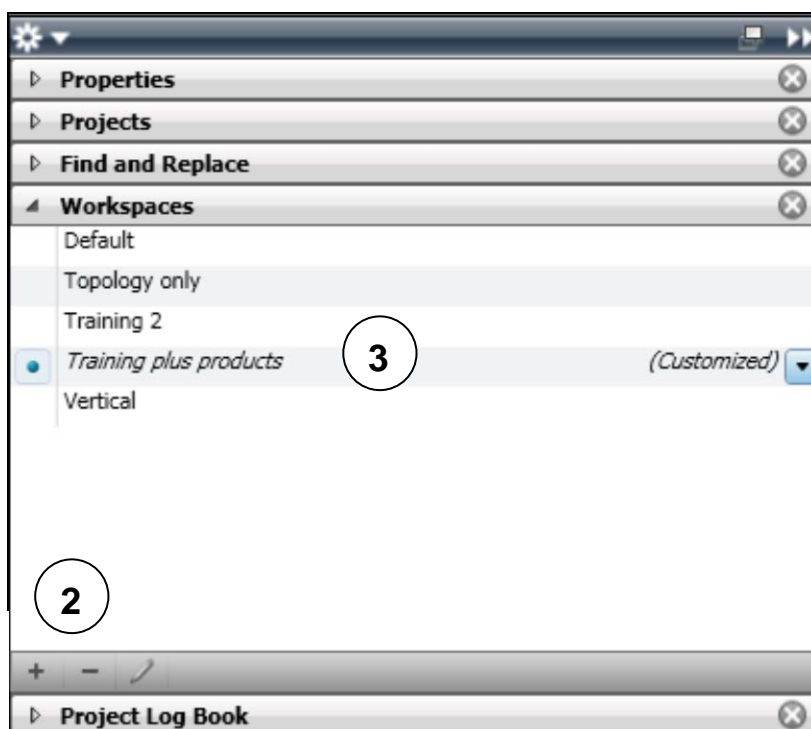

Figure 2: Saving a workspace

Adjusting the presentation of the window:

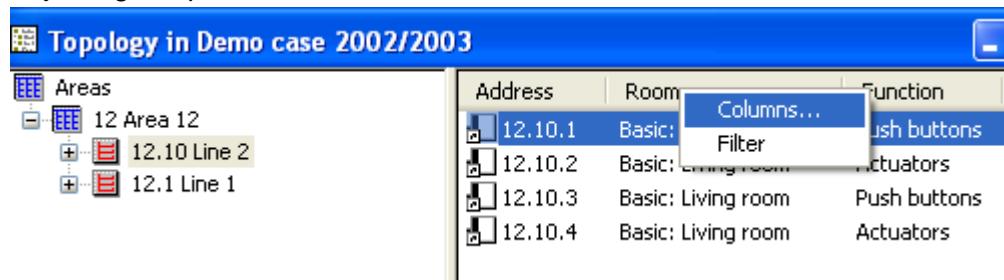

Figure 3: Adjusting the window

Click with your right mouse button on a column heading in the editing window. A pop-up menu will appear, in which you select “Columns”. With “Resize Column” or “Resize All Columns”, the optimum width is set for each column (so that no text is hidden).

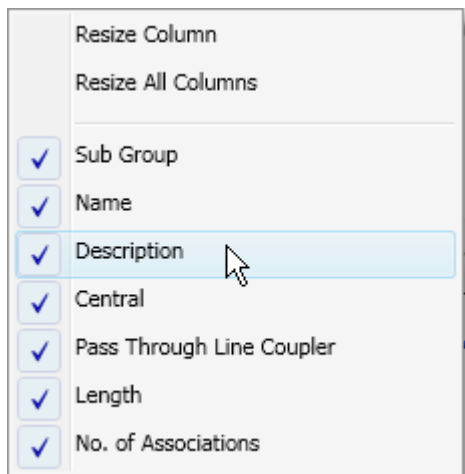

Figure 4: Resizing columns

### 2.3 Other modifiable properties that are not saved in workspaces:

a) Toolbars:

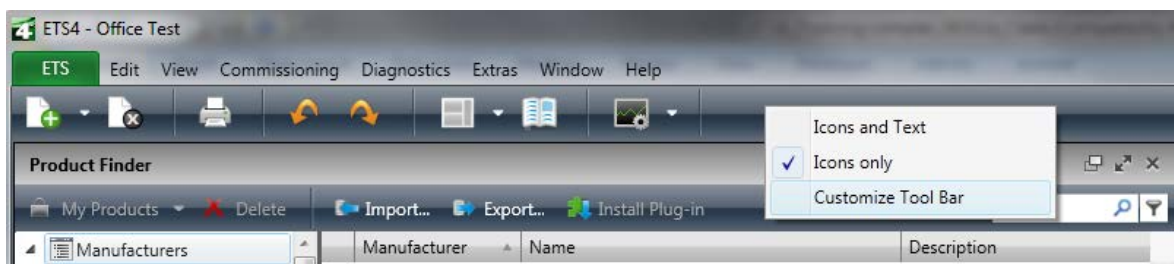
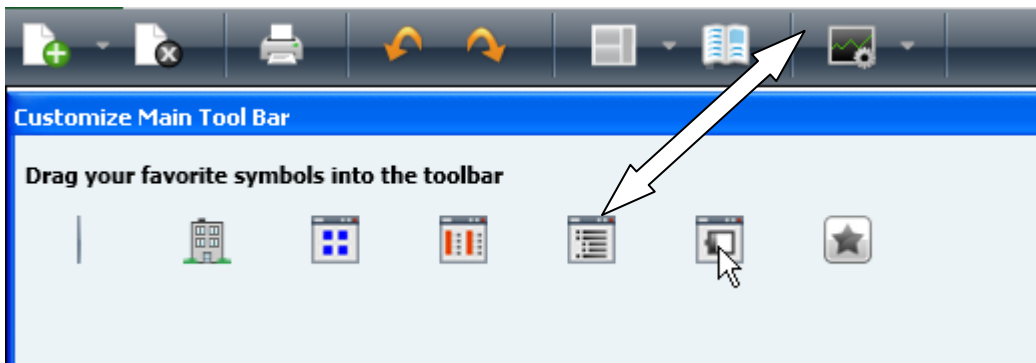

Figure 5: Customising toolbars (1)

Click on the toolbar with the right mouse button. It is possible to choose to display “Icons and Text” or “Icons only”. By clicking on “Customise Main Toolbar”, all required icons can be dragged onto the toolbar (or removed again).



**Figure 6: Customising toolbars (2)**

- b) Favorites list: In this view, links can be created to objects in all possible views which you use frequently (similar to bookmarks or Favorites in a browser). The Favorites list is opened via View – Open New Panel - Favorites. Examples: a line which you are currently editing, a main group in which you are currently continuously making changes or a single central group address that you constantly need for linking to switch actuator objects.

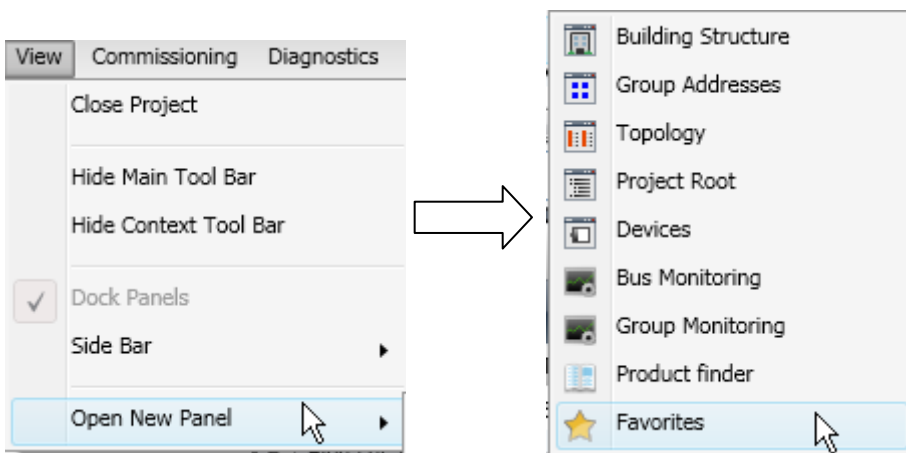

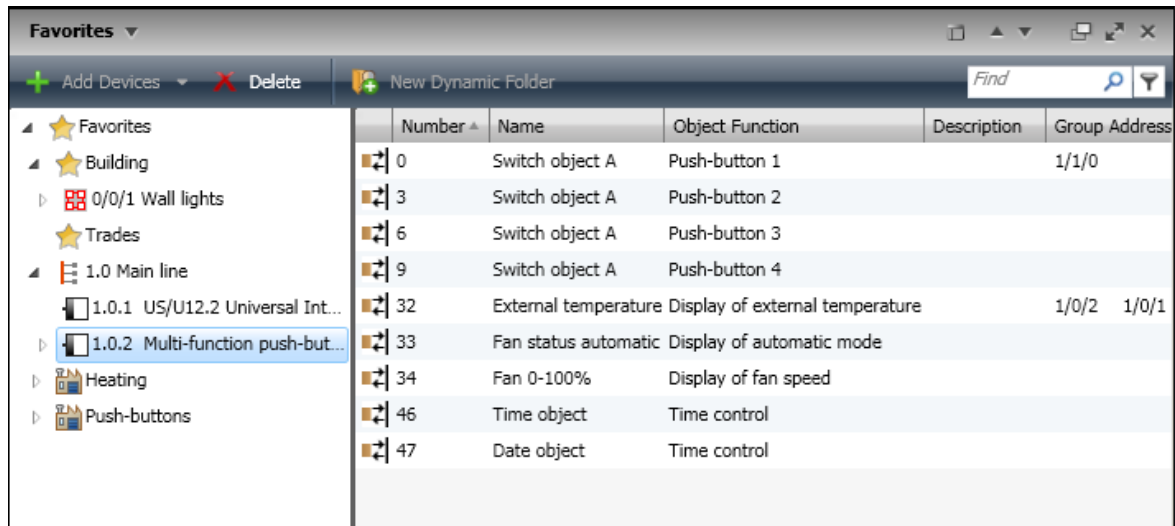

**Figure 7: Open Favorites window, display contents**

The 'Favorites' however cannot be created separately for individual workspaces since they are global links. Thanks to the tool tips displayed, you can however easily recognise which project the respective "Favorite" belongs to. The tip is then displayed, when the associated project is not active.

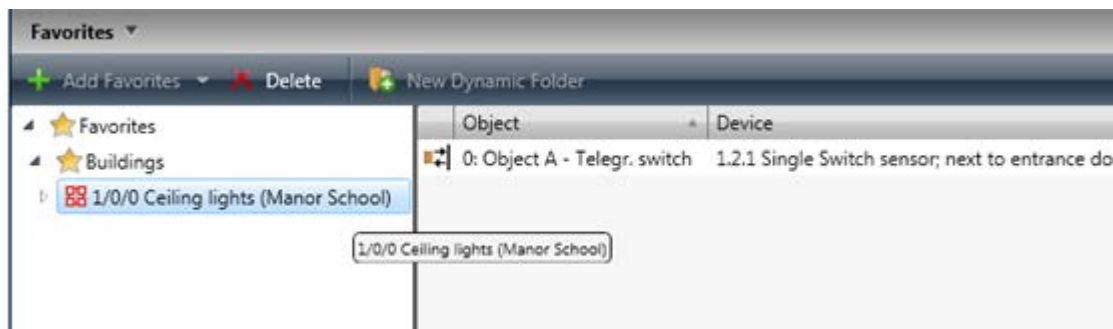

**Figure 8: Information about the origin of the Favorite**

### 3 Shortcut keys

Practised users of a software package can carry out working steps quicker when using the keyboard instead of the mouse. If you wish to use the functions of the main menu, they can all be accessed via the keystroke combination "Alt" + < underlined letter> of the menu item name (context-sensitive shortcut keys). There is also a whole collection of absolute shortcut keys, which can also be displayed and modified via Settings / Shortcuts.

Example: You wish to link a new group address with a displayed object. The object is located in a Favorites list.

The keystrokes are as follows:

Ctrl + F9: Opens the Favorites window (this however only works when at least one window is already open)

You then select the required object – in this case: Switch object A – Push-button

By pressing: “Alt” + B + B; then “Shift” + Tab + Space you access the input line for the new address.

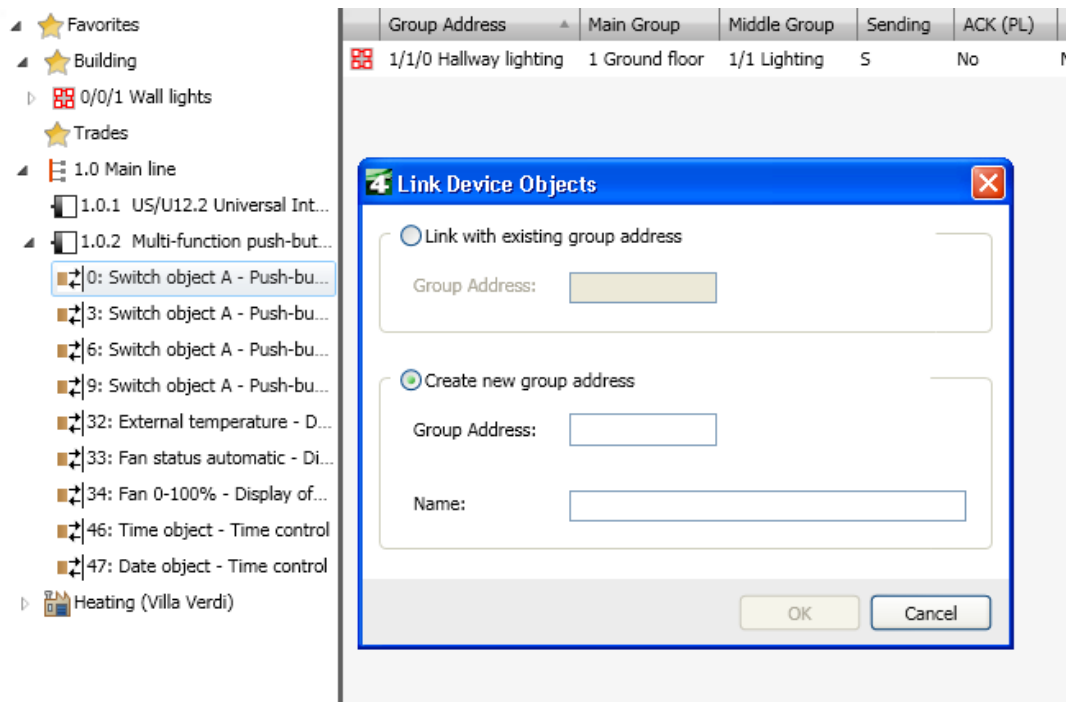



Figure 9: Creating a manual address link via the keyboard

Presentation General		
Presentation Language		
Communication	Print	Ctrl + P
Database	Help	F1
Software Updates	Properties	Alt + Enter
Troubleshooting	New project	Ctrl + N
Import	Next tab	Alt + Right
Shortcuts	Previous tab	Alt + Left
	Next pane	F6
	Previous pane	Shift + F6
	Close window	Ctrl + F4
	Next match	F3
	Previous match	Shift + F3
	Panel 'Buildings'	Ctrl + F7
	Panel 'Devices'	Ctrl + F8
	Panel 'Favorites'	Ctrl + F9
	Panel 'Group addresses'	Ctrl + F10

**Figure 10: All global shortcuts**

## 4 Advanced topology

Topology ▾					
	Line #	Name	Description	Medium Type	Domain Address
▾ Topology	0	Floor Distribution Board H1 F1 Nr. 1	H1 F1 D1	TP	-
▾ Dynamic Folders	1	New line	H1 F1 R1	TP	-
▾ 0 Backbone area	2	Room 1	H1 F1 R2	TP	-
▾ 1 House 1 Floor 1	3	Room 2	H1 F1 R3	TP	-
▾ 2 House 1 Floor 2	4	Room 3	H1 F1 R4	TP	-
▾ 3 House 1 Floor 3	5	Room 4	H1 F1 R5	TP	-
▾ 4 House 1 Floor 4	6	Room 5	H1 F1 R6	TP	-
▾ 5 House 1 Floor 1	7	Room 6	H1 F1 R7	PL	226
▾ 6 House 2 Floor 2	8	Room 7	H1 F1 R8	PL	2
▾ 7 House 2 Floor 2	9	Room 8	H1 F1 R9	PL	218
▾ 8 House 2 Floor 4	10	Room 9	H1 F1 R10	TP	-
▾ 9 House 3 Floor 1	11	Room 10	H1 F1 R11	TP	-
▾ 10 House 3 Floor 2	12	Room 11	H1 F1 R12	TP	-
▾ 11 House 3 Floor 3	13	Room 12	H1 F1 R13	TP	-
▾ 12 House 3 Floor 4	14	Room 13	H1 F1 R14	TP	-
▾ 13 House 4 Floor 1	15	Room 14 H1 F1 Nr. 2	H1 F1 D2	TP	-
▾ 14 House 4 Floor 2					
▾ 15 House 4 Floor 3					

Figure 11: Max. expanded topology with proposed text

### 4.1 Structuring and planning reserves

In the diagram above, you can see how to create many areas and lines in a project: 15 areas, and in each area 16 lines. You can see by the name how the topology could be aligned to the building structure. This of course depends on the size and structure of the relevant project. There is no single model solution for this! It is advisable to design a larger project completely without topology and to establish the assignment in the topology after completion of the project design. What is the best way to proceed?

- ✚ Observe a **reserve** of approximately 20% per line segment (i.e. for maximum 64 bus devices, this amounts to approximately 50 bus devices).
- ✚ **Central devices** should be installed in main lines or in backbone lines.
- ✚ **Devices of connecting room groups** should also be put in the **same line segment** (under no circumstances several segments in a room should be mixed, unless the upper limit of 64 (or 50 with reserve) has been exceeded. In that case, this should be clearly documented!)
- ✚ On the same floor (or in the same house) you should if possible only install one area (do not fill up when 1 or 2 lines are free).



## 4.2 Support from ETS when setting up larger size topologies:

### 4.2.1 Creating several areas

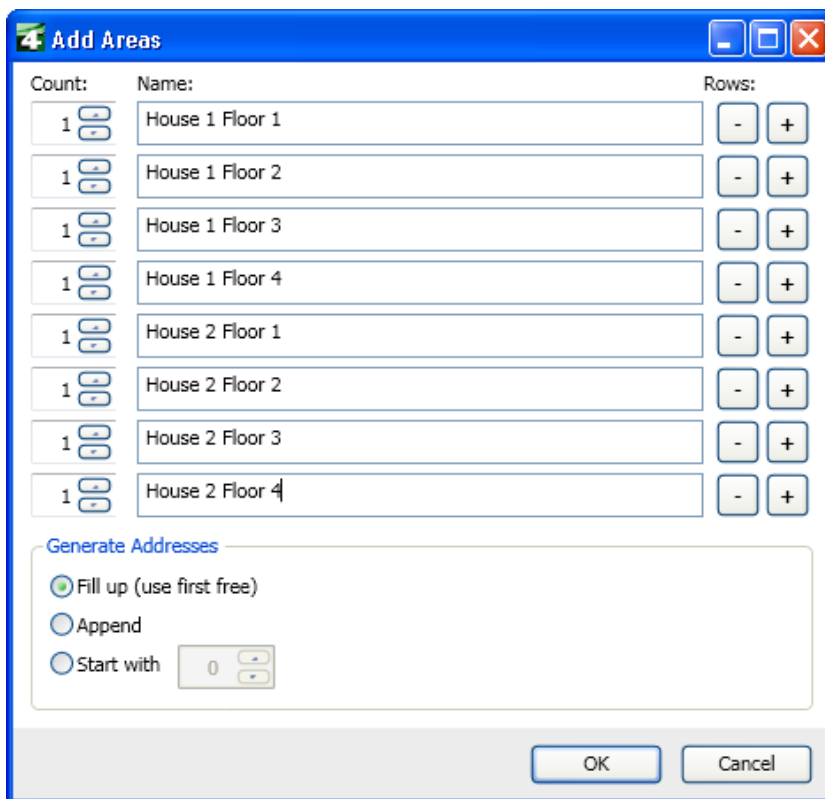
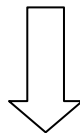
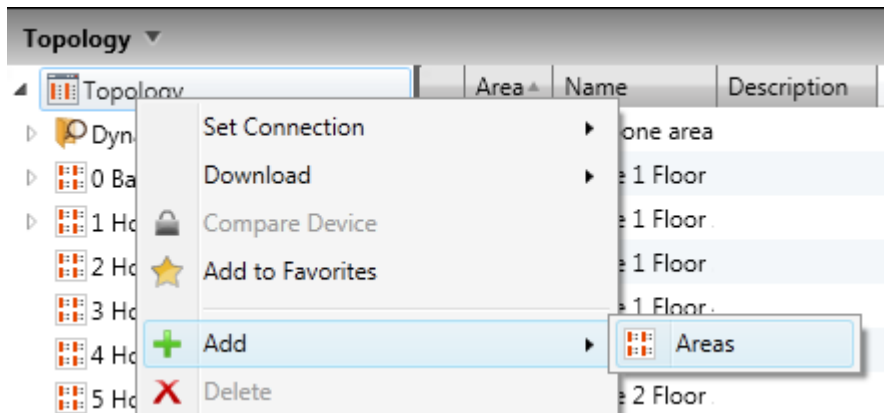

**Figure 12: Creating several areas (1)**

Simply click on the “Topology” symbol in the “Topology” window with the right mouse button and enter the areas in succession in the dialog box. If desired, the strategy of generating the addresses must be customised; the settings are adopted by pressing OK and the areas are created.

Area	Name	D
0	Backbone area	
1	House 1 Floor 1	
2	House 1 Floor 2	
3	House 1 Floor 3	
4	House 1 Floor 4	
5	House 1 Floor 1	
6	House 2 Floor 2	
7	House 2 Floor 2	
8	House 2 Floor 4	

Figure 13: Creating several areas (2)

### 4.2.2 Creating several lines

The same procedure can also be applied to lines. In this case, click with your right mouse button on the relevant area, and proceed as in the paragraph above!

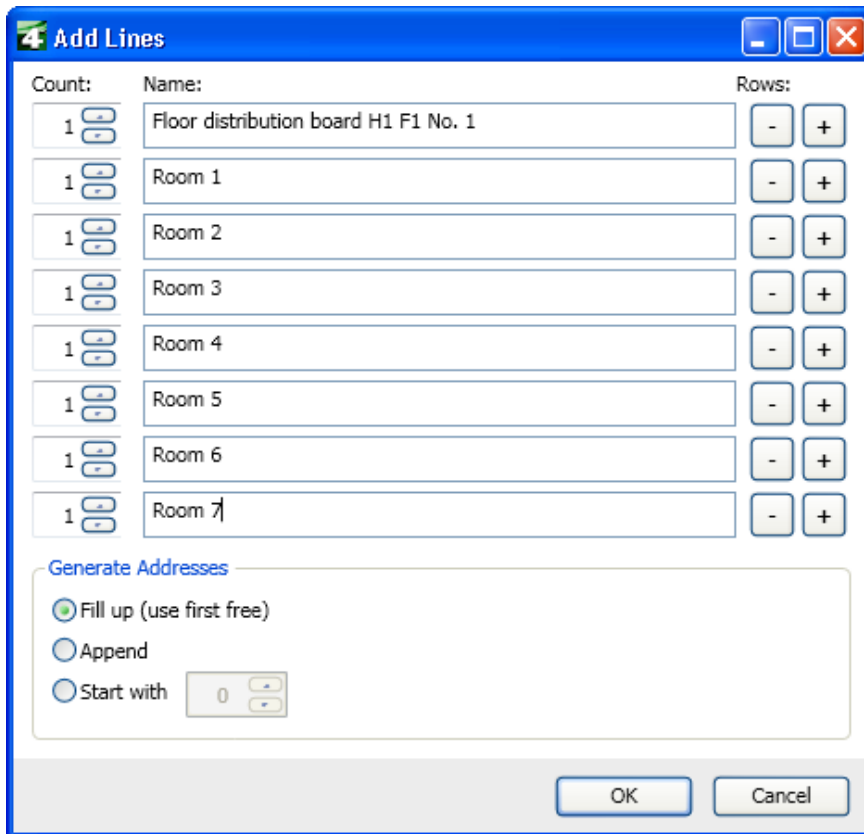

Figure 14: Creating several lines

Note: If the same line structure is required in all the areas, it is advisable instead of first creating all the areas and then all the lines per area to create and label an area completely including its lines and then to duplicate it using copy and paste.

### 4.2.3 Find and replace - Strategy

Text alterations can be carried out very conveniently using “Find and Replace”: First mark a line in the list that is to be modified, then activate the “Find and Replace” function. Enter the search text and replacement and then click on the appropriate button underneath.

Line	Name	Description	Medium Type	Domain Address
0	Floor distribution board H1 F1 No. 1	H1 F1 D1	TP	-
1	Floor distribution board H1 F1 No. 2	H1 F1 D2	TP	-
2	Room 1	H1 F1 R1	PL	89
3	Room 2	H1 F1 R2	IP	-

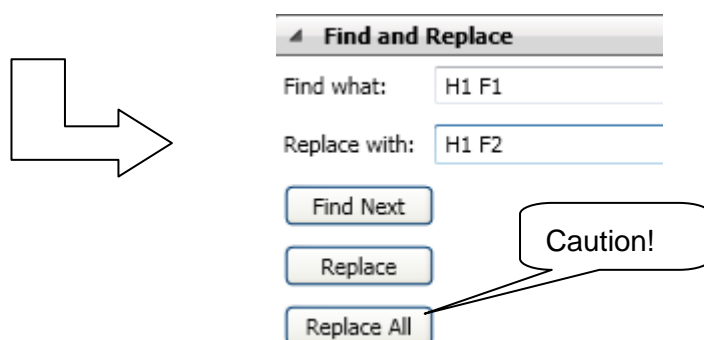

Figure 15: Find and replace

This process should however be used with care; e.g. text can also be modified inadvertently by pressing the “Replace All” button. It is better to first locate the text that needs to be modified with “Find” and then to correct one after the other with “Replace”.

## 5 Different media (Powerline, TP, IP)

Three media types are supported directly by ETS: Twisted Pair, Powerline and IP. This can also be distinguished in the topology. All line types can be freely combined with each other. In order to link them, you need the appropriate media coupler. The project engineer shall however ensure that settings are meaningful: if Powerline lines are created for example, the overlying connecting line (the main line) must be of type TP.

Then again, the media setting does not necessarily have something to do with the coupler that is being used: Even if an IP router is used as a line coupler, the line must be set as a TP line! The media that is supported by a device or on which it can be operated can easily be seen in the Catalogs view in the column “Medium Type”.

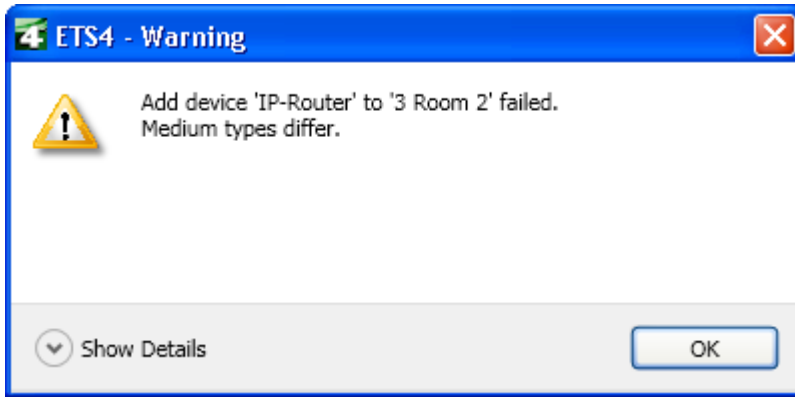

**Figure 16: Error message when inserting an IP router in an IP line**

The respective transmission medium can be selected in the “Medium Type” column; in the case of Powerline, the necessary domain address is automatically generated via a random generator. It can be edited at a later date, if necessary.

All non-TP lines are also marked by corresponding symbols, so that they can immediately be distinguished from the standard TP lines.

Line	Name	Description	Medium Type	Domain Address
0	Floor distribution board H1 F1 No. 1	H1 F1 D1	TP	-
1	Floor distribution board H1 F1 No. 2	H1 F1 D2	TP	-
2	Room 1	H1 F1 R1	TP	-
3	Room 2	H1 F1 R2	IP	-
4	Room 3	H1 F1 R3	TP	-
5	Room 4	H1 F1 R4	PL	-
6	Room 5	H1 F1 R5	TP	-

**Figure 17: Topology with different media**

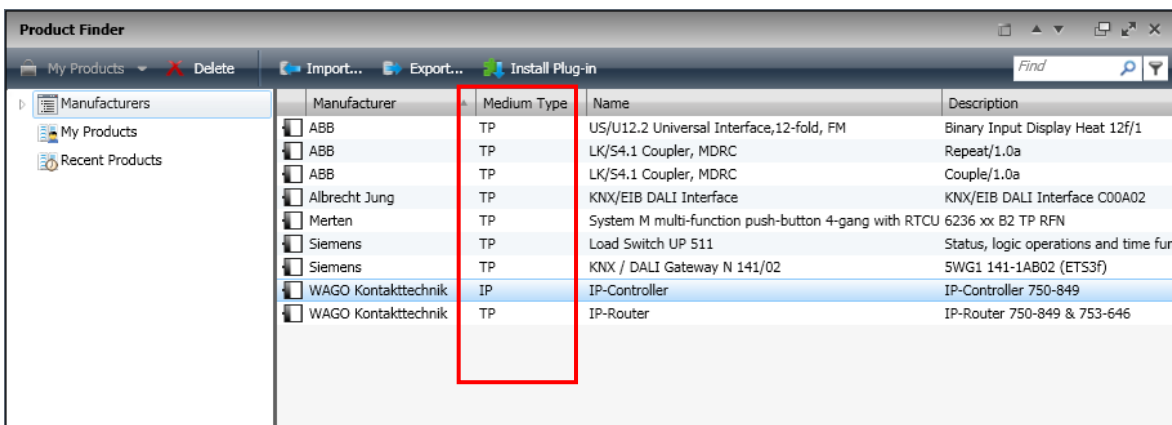

**Figure 18: Media types of the devices**

## 6 Interlinked building structures

The Building View is indispensable for the project designer of a larger project, for documentation purposes alone. Only in the Building View, can it be completely understood where each component is installed. You have to maintain the following structure in ETS: buildings – building part (floor) – rooms/cabinet. However, there is an exception to the rule: room/cabinet can also be located directly under a building. Devices can be inserted in four locations, in a room / distribution cabinet, in the “Devices” view, in the “Project Root” view or in the “Topology” view. All the devices that are not created via the building structure (in the topology and trades) are inserted first. They should be linked in the correct place in the Building View at the latest when the project is completed. A problem regularly occurs if a building has not been built according to the “standard” e.g. in other words it does not have clearly recognisable floors. In this case, the interlinking of the building parts will help you further. This structural element can be freely subdivided; moreover rooms/cabinets can also be inserted directly in buildings. This may be necessary when you need to design a project for a sports centre for instance. The rooms are inserted in the building and there are no floors.

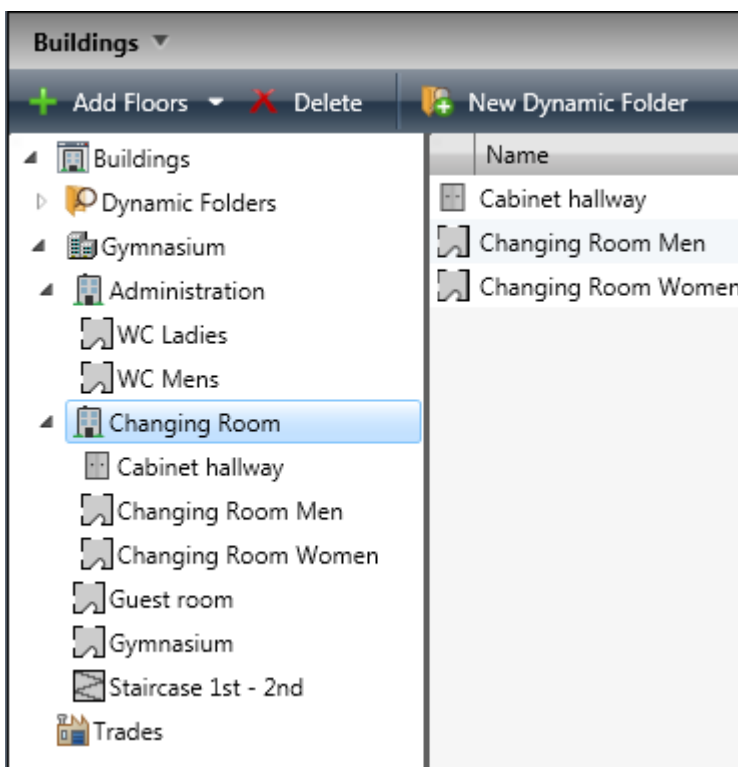
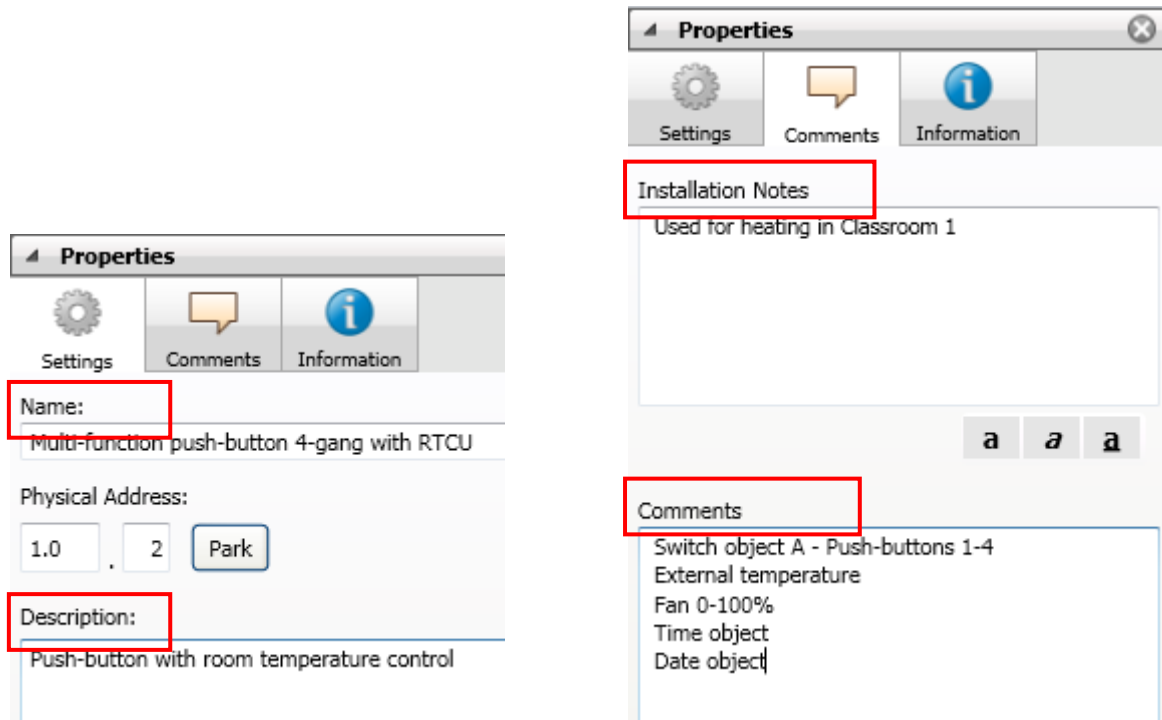

Figure 19: Example of an interlinked Building View

### 6.1 Inserting devices, systematic descriptions

The devices are inserted after setting the structure of the building (see Project Design, Basic). Four fields can be used to describe each device: Name, Description, Comments and Installation Notes.

The differences lie in the field size and the presentation in the columns or in the download dialog.



**Figure 20: Text description fields for the devices**

The description field has only 80 characters, the name can however be 255 characters long, whereas comments and installation hints can have an unlimited length. Moreover they can be formatted (bold, italic, underline, and colour). The name and the description are also displayed in the display columns of the device views such as line view, room view or all devices (unless they have been “hidden” via the workspace setting). They are also displayed when downloading.

The installation notes and the comments can however only be viewed in the Properties dialog or printed out in the documentation. They are generally used (as the name already indicates) to make detailed comments about the commissioning or installation. However, in the case of devices with a large number of channels, it is often necessary use these for commenting as the name and description fields cannot take all channel designations due to their size limits.

Finally, there is also an editing status below the description field, which you should use to document the current editing state of the respective device. Via a dynamic folder with the criterion “Completion status is not accepted”, you can then view at any time all the devices that have not yet been accepted by the customer.

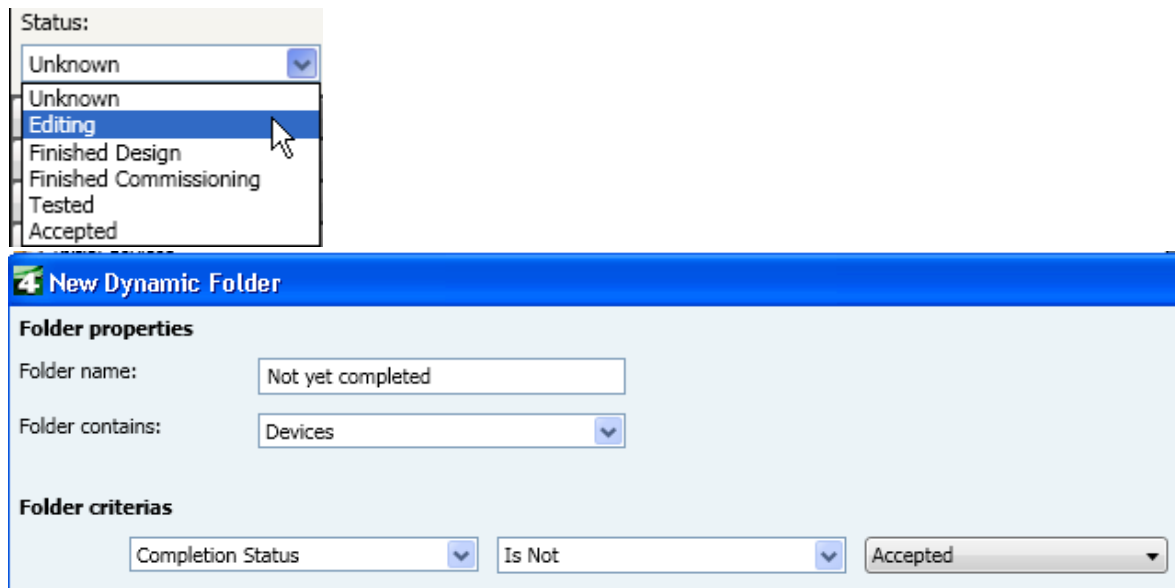

Figure 21: Editing (completion) status

## 6.2 Examples of device descriptions:

You should use a systematic legend when creating the description. It should contain the following data in an abbreviated format:

- ✚ Place of installation, e.g. DB1
- ✚ Device type, number + number of channels (e.g. SDA 1f = 1-fold switch/dim actuator, ShA 4f= 4-fold shutter actuator, SwitchA 8f= 8-fold switch actuator, PB 2f= 2-fold push-button)
- ✚ Channel number + its function, e.g. Ch1\_on/off
- ✚ Functioning location of channel, e.g. R12

### Example:

**SubDB\_H1F3\_SwitchA\_4f(1)\_R12\_Ch1\_L05,**

**Ch2\_L06,Ch3\_L07,Ch4\_L08\_on/off**

**Means: Lights 5-8 in room 12, 3rd floor of the first house, switching, executed at switch actuator no. 1, which is installed in the distribution board on the 3rd floor.**

## 7 Group addresses Advanced

### 7.1 Structure of the addresses

ETS offers 3 options for structuring addresses:

- a) 2-level (historically from ETS1, practically not used anymore)
- b) 3-level (used in ETS2 and ETS3, also suitable for larger projects, fixed folder sizes and quantities on 3 hierarchical levels)
- c) Free address structure: The user can set up his own, interlinked structures within the entire 16 bit address range.

### 7.1.1 3-level address structure

On the basis of years of experience, the author recommends the following structure for a single building:

- MaGrp. 0 Central functions
- MiGrp. 0/0 – 0/7: Function-dependant subdivisions of the central functions
- MaGrp. 1 – 13: Floor no.
- MiGrp: 0-7 Functions per floor
- SGrp: 0-255: Room features per function and floor

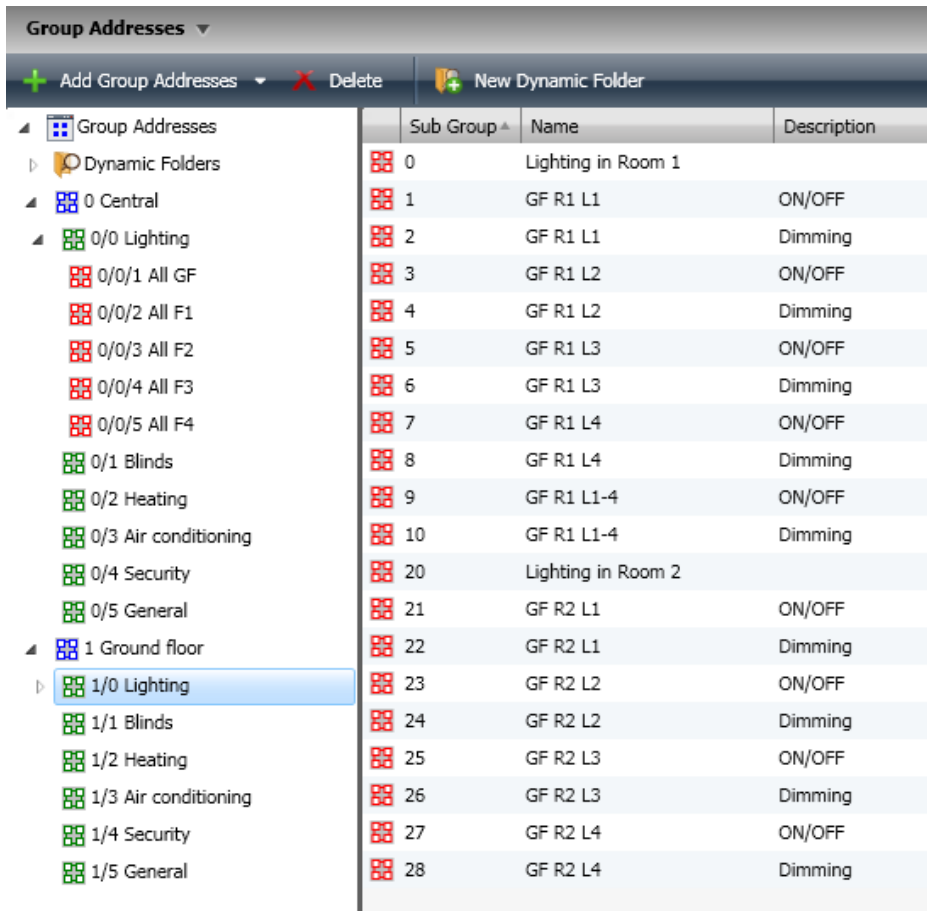

Sub Group	Name	Description
0	Lighting in Room 1	
1	GF R1 L1	ON/OFF
2	GF R1 L1	Dimming
3	GF R1 L2	ON/OFF
4	GF R1 L2	Dimming
5	GF R1 L3	ON/OFF
6	GF R1 L3	Dimming
7	GF R1 L4	ON/OFF
8	GF R1 L4	Dimming
9	GF R1 L1-4	ON/OFF
10	GF R1 L1-4	Dimming
20	Lighting in Room 2	
21	GF R2 L1	ON/OFF
22	GF R2 L1	Dimming
23	GF R2 L2	ON/OFF
24	GF R2 L2	Dimming
25	GF R2 L3	ON/OFF
26	GF R2 L3	Dimming
27	GF R2 L4	ON/OFF
28	GF R2 L4	Dimming

Figure 22: Example of group address structure and designation



## 7.2 Description format

A group address describes a function. It is therefore also directed at the operational equipment and not at the bus devices concerned performing this function (sensors – actuators). For instance, you want to dim light 5 on the 1st floor in the 2nd room. It is not appropriate to give a group address such a long description. That is why you should establish a scheme before starting a project. It should contain abbreviations with all the necessary information about

- ✚ **location** where the function takes effect, e.g. Building-floor-room
- ✚ **controlled equipment** or equipment group, e.g. Light 1, Shutters 1-4, Heating for whole floor
- ✚ **Type of function** (e.g. dimming, switching, set value, shutter movement)

(see also the comments in the device lists).

Example: A block of 3 buildings, 4 floors per building, and up to 20 rooms per floor:

- 1) H1F3R12\_L05\_on/off = means: Lights 5 in room 12, 3rd floor, building 1, switching.
- 2) H3F2R08\_L01-04\_dim = means: Lights 01 – 04 in room 8, 2nd floor, building 3, dim continuously.
- 3) H2F3R07\_Shu01-03\_stop = means: Shutters 1-3 in room 7, 3rd floor in building 2, stop
- 4) H2F0R03-06\_Shu\_mov = means: Move all shutters (up/down) in rooms 03 – 06, ground floor, building 1
- 5) H1-3\_Light\_central\_on/off = means: Central switching of all the lighting in buildings 1, 2 and 3.
- 6) H1F1R14\_Heat\_SetPt= means: Heating information – desired setpoint temperature in room 14, 1st floor, building 1.

The examples mentioned above illustrate how you can establish self-explanatory descriptions with only few characters. Please note that the name for the location and equipment group should be re-used for the actuator (see Inserting / Copying devices). This makes the assignment much easier afterwards.

### 7.3 Group address settings

Sub Group	Name	Description	Central	Pass Through Line Coupler
1	GF R1 L1		No	No
2	GF R1 L1		No	No
3	GF R1 L2		Yes	No

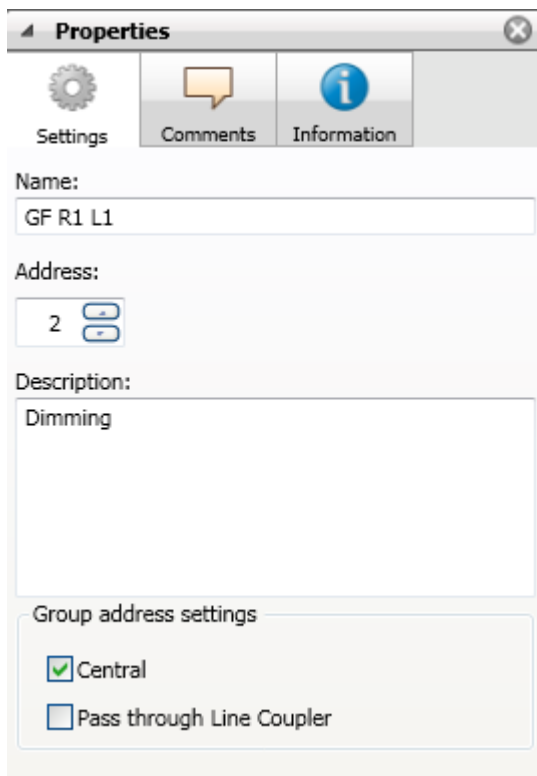

**Properties**

Settings | Comments | Information

Name: GF R1 L1

Address: 2

Description: Dimming

Group address settings

Central

Pass through Line Coupler

**Figure 23: Address settings**

When designing a project, different options allow you to determine how group addresses are to be handled.

- Pass through Line Coupler: When a group address is set to 'pass through', it is entered in the filter tables of all line couplers. It is therefore not filtered when telegrams containing this group address do not actually belong in the line they are sent to. You can choose this option to enable e.g. central functions that are used in almost every line. In this case, it will not be necessary to re-program line couplers, when the installation is extended in the future.
- Central function: This property only has significance inside the ETS. Group addresses that are set as such will be taken over unchanged in newly created devices when you "Copy with options". This will of course save you considerable copying work since only the local group addresses will have to be newly assigned; the central functions will be kept.

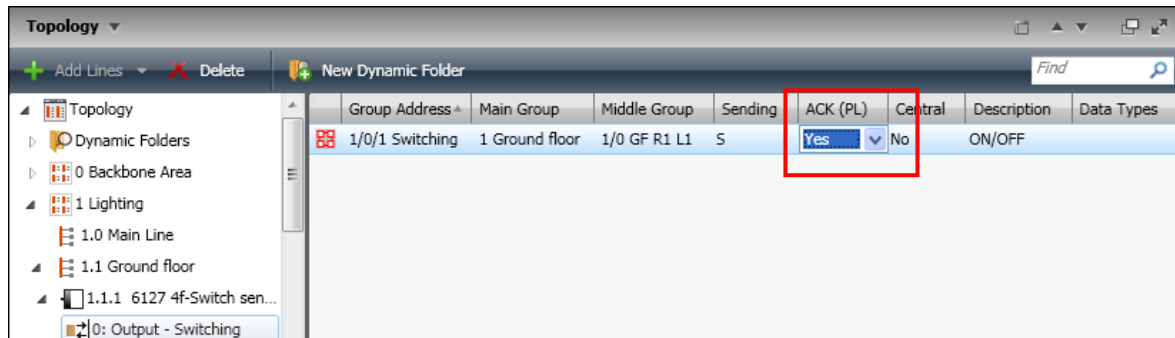

**Figure 24: Setting the group speaker: ACK (PL) = Yes**

- c) **Group speaker:** Only relevant for Powerline. In Powerline systems, only one device must be available for each group address to send an acknowledgement (Acknowledge) when receiving a group telegram with this address. A group speaker property must be assigned to a Powerline device, i.e. in the object which is linked to the corresponding group address. Please note: Just as the sending address in the case of a “Transmit” flag is an object property assigned to this specific group address, the same applies to the group speaker flag: you first select the device (in Topology view or in another view), expand the objects in the tree structure and select the object with the corresponding group address, so that it appears in the right window pane. The option “Yes” can then be set in the ACK (PL) column (see figure above).

## 7.4 Creating large numbers of group addresses

### 7.4.1 Directly in ETS:

As in the topology, the “Object generator” can also be used for the address structuring. You can use 2 strategies:

1. Complete each main/middle/subgroup individually with addresses.
2. Copy an existing structure from a main group into another.

Example for strategy 1: Creation of new floor-related main groups

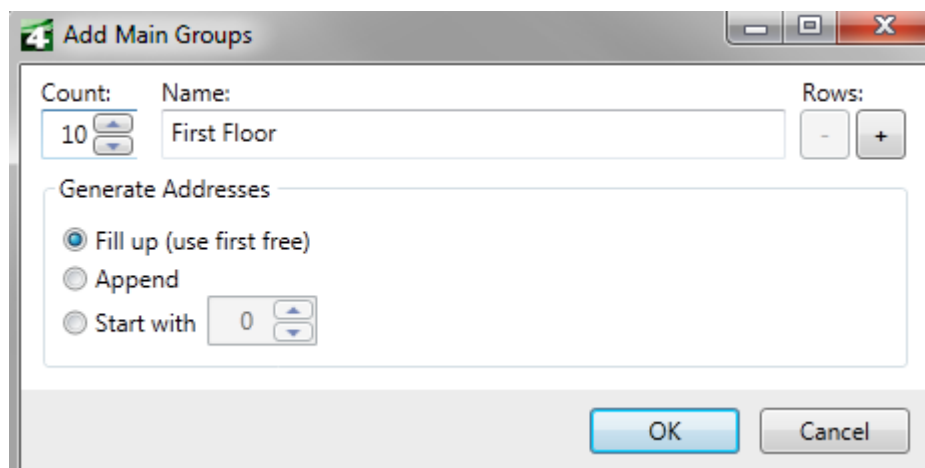

**Figure 25: Creation of main groups (1)**

Result:

Address	Name	Description
0	Central	
1	Floor (1)	
2	Floor (2)	
3	Floor (3)	
4	Floor (4)	
5	Floor (5)	
6	Floor (6)	
7	Floor (7)	

**Figure 26: Creation of main groups (2)**

The text must still be edited e.g. the floor numbers must be inserted. This can be done however without subsequent editing if you use the row expansion option (and then only 1 instance per row):

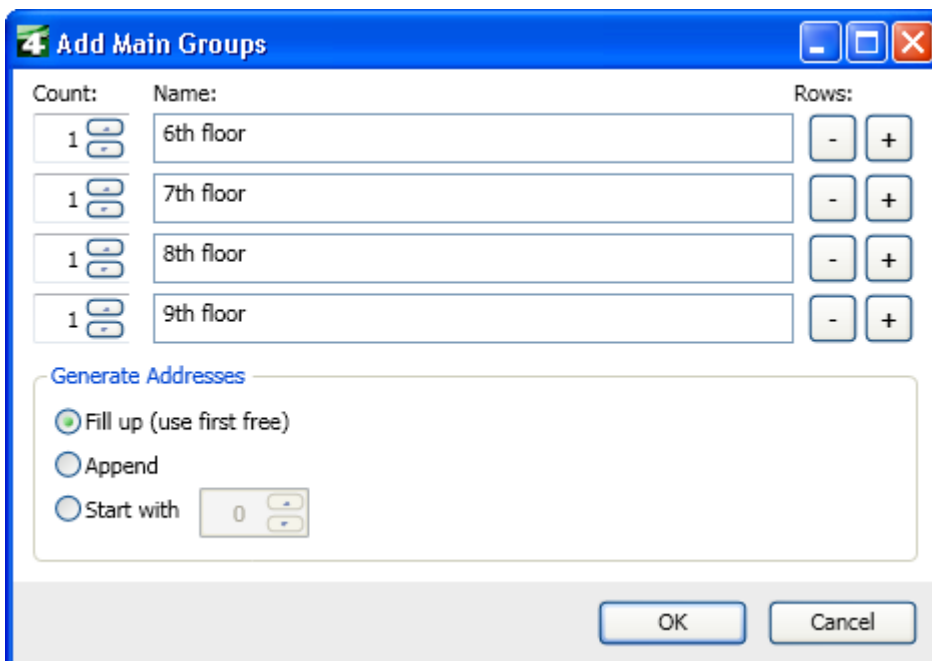

**Figure 27: Creation of main groups (3)**

Example of strategy 2:  
Copying an existing structure:

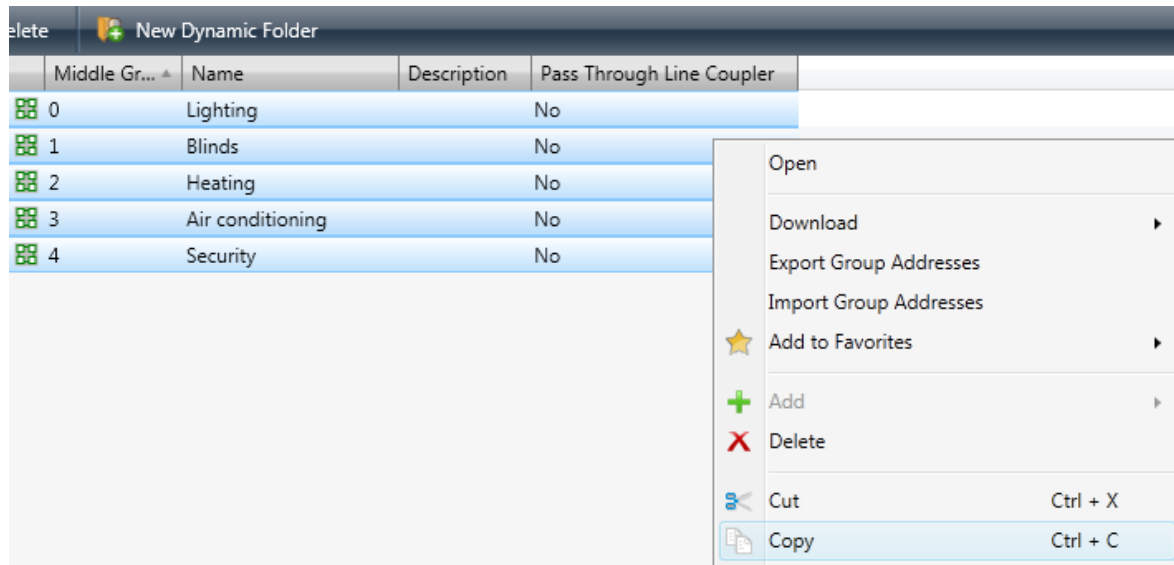

**Figure 28: Copying (middle) group addresses (1)**

Then click in the desired main group and press “Ctrl + V”.

Result:

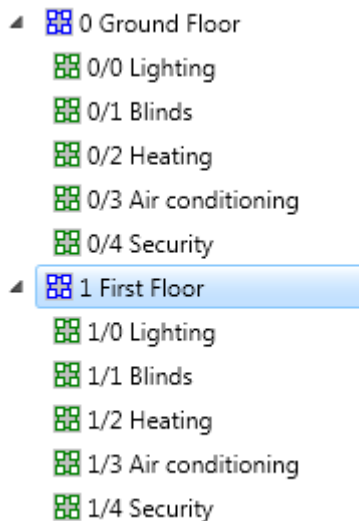

**Figure 29: Copying (middle) group addresses (2)**

**7.4.2 Via export to / import from EXCEL:**

Group addresses can be directly exported from the Group Addresses window and then re-imported. Professionals can use this to generate the address lists conveniently outside ETS e.g. in a spreadsheet program such as EXCEL. This section briefly describes the process: To obtain a suitable CSV file for further processing as a template, one should first generate a small starting structure in ETS. This is then exported as a CSV file in 3/3 format with a header line. In EXCEL, it is important that separators are immediately recognised, TAB being the most suitable, so that EXCEL also creates the 6 columns required for a 3-level group address structure. The required addresses can now be generated in EXCEL. The sequence is of no importance. One should however avoid ambiguities or address numbers outside the defined range.

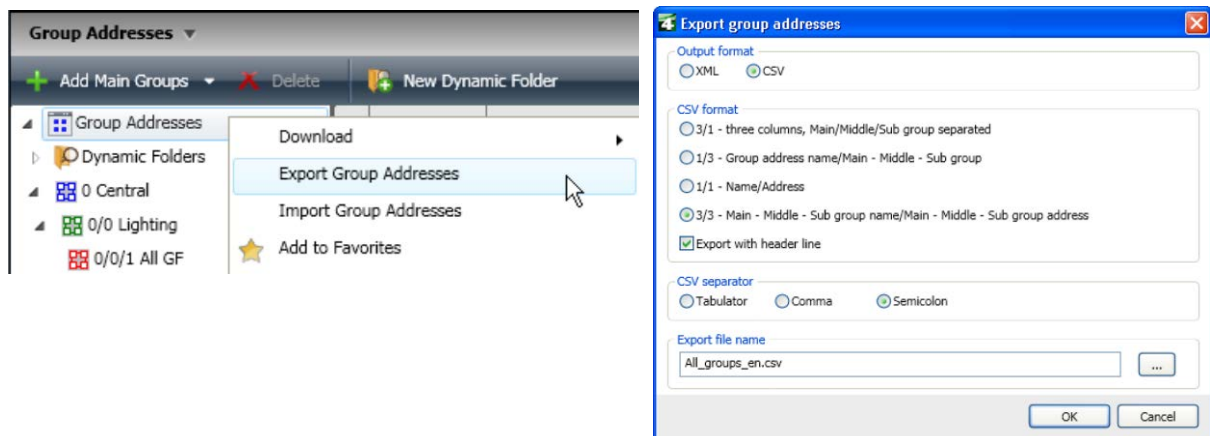

Figure 30: Exporting a group address – CSV file to EXCEL – Format setting

A	B	C	D	E	F
Main	Middle	Sub	Main	Middle	Sub
Central			0		
	Lighting		0	0	
		All GF	0	0	1
		All F1	0	0	2
		All F2	0	0	3
		All F3	0	0	4
		All F4	0	0	5
	Blinds		0	1	
	Heating		0	2	
	Air conditioning		0	3	
	Security		0	4	
	General		0	5	
Ground floor			1		
	GF R1 L1		1	0	
		Lighting in Room 1	1	0	0
		GF R1 L1	1	0	1
		GF R1 L1	1	0	2
		GF R1 L2	1	0	3
		GF R1 L2	1	0	4
		GF R1 L3	1	0	5
		GF R1 L3	1	0	6
		GF R1 L4	1	0	7
		GF R1 L4	1	0	8
		GF R1 L1-4	1	0	9
		GF R1 L1-4	1	0	10

Figure 31: View of the CSV file in EXCEL

### 7.4.3 Free address structure

With the introduction of the fourth generation of ETS, the option was also created to freely arrange group addresses. The 2- or 3-level structures that were randomly created in the early years of the KNX/EIB system have certain limitations, as the addressable group ranges are numerically restricted. If someone has created e.g. a “Central” middle group and only requires approx. 10 addresses, he “wastes” the remaining 246 in this middle group (which he could for instance have used for the “Lighting” middle group).

The free address structure can now be organised as desired. The structure is also not limited in terms of number of levels. A planner can thus use up all available addresses without gaps.

It should however be noted that export and import is only possible via the XML format. You therefore require an XML editor instead of a standard spreadsheet. It is also not possible to change from the 2/3-level format to the free structure and back again.

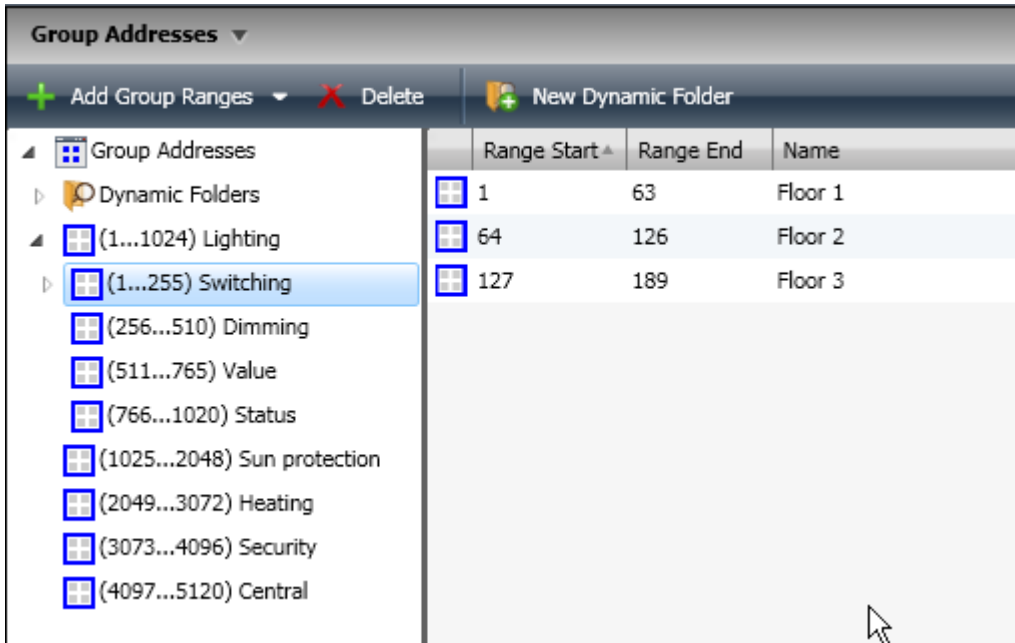

Group Addresses		
Range Start	Range End	Name
1	63	Floor 1
64	126	Floor 2
127	189	Floor 3

Figure 32: Representation of free group addresses

## 8 Professional functions and tools

Currently many of the announced functions are still unavailable. This can be seen when looking at the licence directory. The copying and pasting of entire building structures is for example currently being expanded, so that after a copying process you will no longer have the time-consuming task of amending the text and other properties of the copied objects. The fact that it is currently not possible to copy a product including its group addresses 1 to 1 between different projects will then also be rectified. Hence, this chapter will be constantly changed and expanded in the following months.

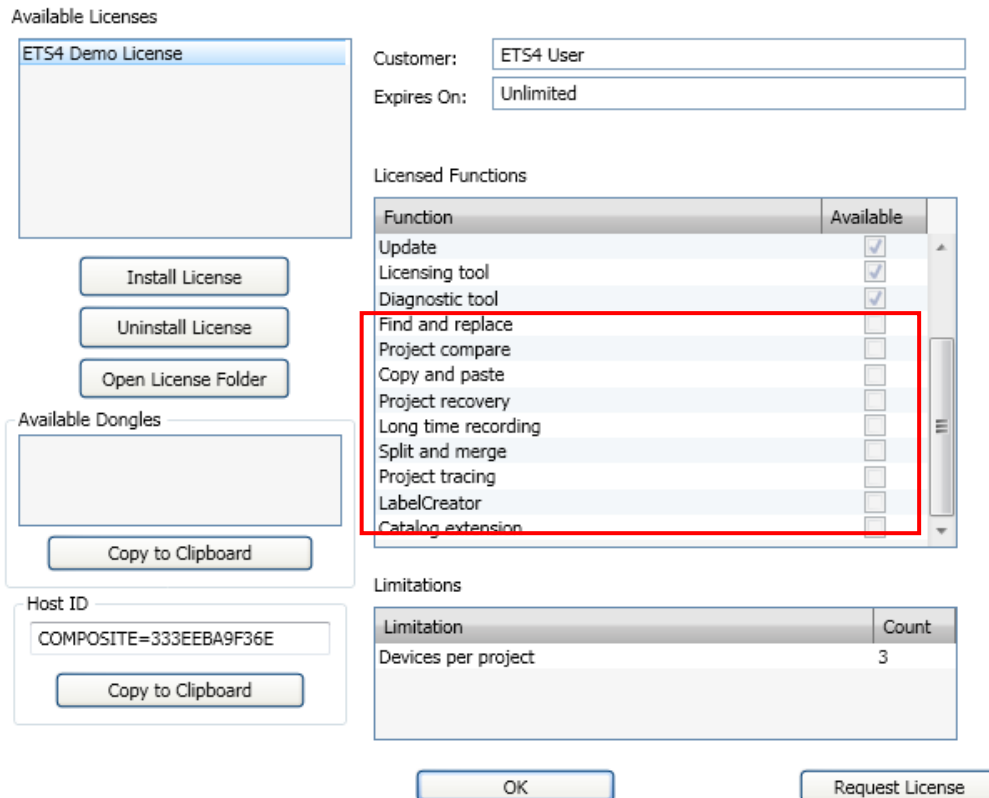

Figure 33: Licence directory, current options

### 8.1 Copying with options

You can basically copy all elements in a project, i.e. group addresses, buildings, building parts, rooms, lines etc. You can do this either with drag & drop (hold down the Ctrl key) or just as in Windows using the Ctrl+C, Ctrl+V key (or by selecting copy and paste in the menu bar).

Number	Name	Object Function	Group Addresses
1	Move shutter	Telegr. Move up/down	1/0/1
2	Operation mode	Frost/heat protection	1/0/2
3	Operation mode	Night operation	1/0/3
4	Operation mode	Comfort mode	1/0/4
5	Control value	Heating (switching)	1/0/5
7	Current temperature	Room temperature	1/0/6
8	Base setpoint	Telegr. temperature	1/0/7
9	Current setpoint	Telegr. temperature	1/0/8

Figure 34: Example: Copying devices (1)

Starting point: The linked room thermostat 1.2.1 should be copied 5 times. First select it, then simply press “Ctrl + C” (or click on “Copy” in the context dialog via the right mouse button).

**Important:** The newly created group addresses all receive identical names i.e. without the addition “Copy of” etc. It is therefore advisable to use the same type of text element e.g. the room name which is saved in the “Description” column in this case. The



screenshot shown below has already “prepared” the 5 other rooms as regards group addresses. As the ETS will create 10 new addresses per device, they will be inserted precisely in the gaps between the headings!

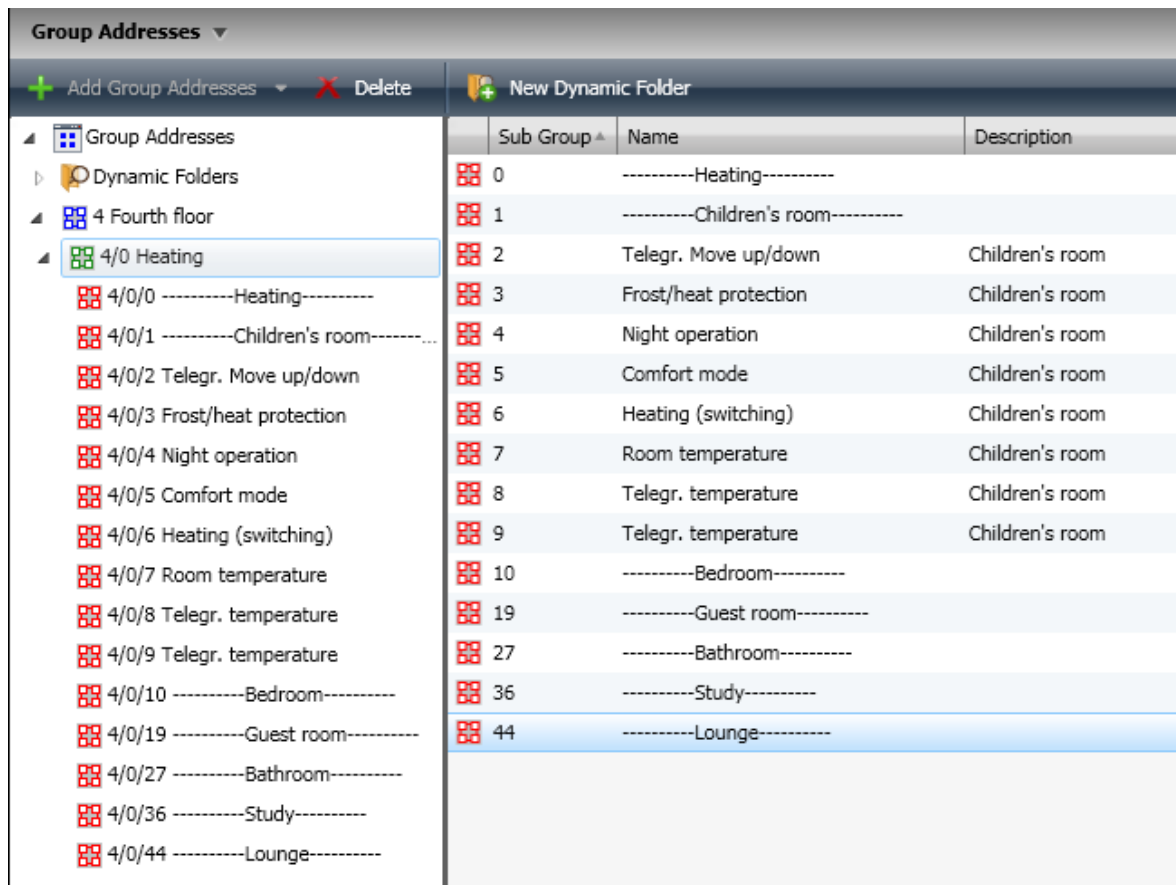

**Figure 35: Example: Copying devices (2)**

Now mark e.g. the target line (in this case 1.2 again) and press “Ctrl + V”. The following dialog opens:

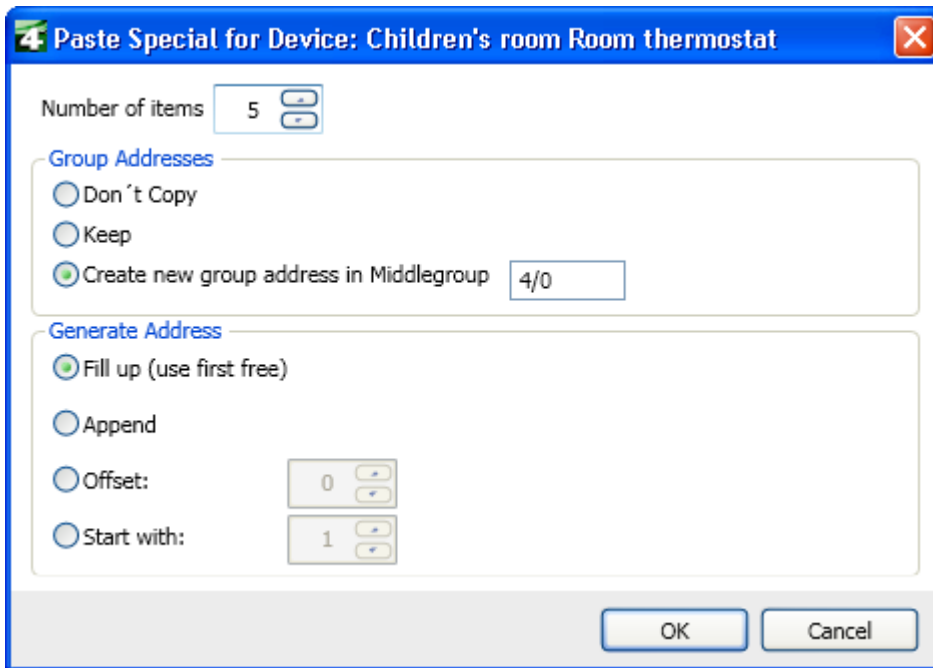

**Figure 36: Paste Special dialog**

When you are copying devices, there are various options.

The marked devices can be duplicated with all additions and properties (e.g. also group addresses, modified parameters etc.). This saves time as the new devices are automatically inserted and their parameters and address links are taken over from the original device 1 to 1. There are three strategies: to create, keep or omit group addresses.

1. **Keep:** This option is suitable for copying totally identical devices (for instance a switch in a corridor or staircase). No new group addresses are created, just one new individual address. The parameter settings are taken over from the source object.
2. **Create new:** This option saves you from manually creating and linking new group addresses. However, you should prepare this option very carefully. Reason: Each open address link is indeed newly created, but if you have not copied its communication partner, ETS is unaware of this. After subsequent copying of the forgotten device, further new addresses are created, which do not match those created during the previous copying process. This means that whenever you copy with the option to create new addresses, all involved devices must be copied in one go. Exceptions to this are the “central addresses”: they are not changed when copying. You can use this feature to your benefit to avoid the “cloning” of addresses that do not have a sender or receiver. Real central functions are of course also not created as new copies when using this option.
3. **Do not create address links:** Choose this option when you only need a device that does not have the standard parameters from the catalog, but those you previously configured.

The result of the copying operation is too extensive to show here. However, the description of the new devices and their addresses still need to be adapted. As we have selected the room name for all elements, it is now simple to create the correct text using “Find and Replace” (as shown earlier).

## 8.2 Undo function

When you are working on a project, you often face the issue of restoring an intermediate state, when wishing to do certain things in a different way.

The function called “Undo / Redo” can be used for this purpose. It allows reversing a number of steps or restoring them under certain conditions.

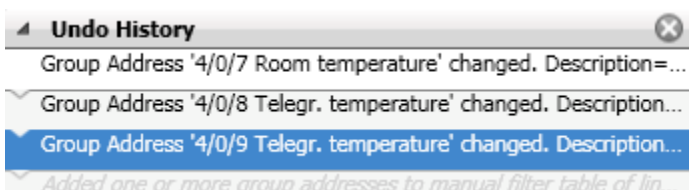
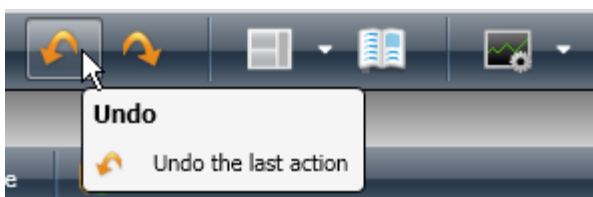

**Figure 37: Undo/Redo in the toolbar / List of reversible actions**

For this, ETS saves all the actions of the project engineer. The maximum number of actions that are saved can be set via “Settings” – “Presentation General” between 0 and 200. If this number is reached and there are further entries, the oldest entry is always overwritten. Since all the previous actions are also displayed in a list, you are able to reverse a series of actions in one go, especially if they are directly linked to each other (example: Find and Replace steps). This function however also consumes performance resources. When you for instance use the complex “Copy with options” function described before for entire building structures, you have to basically calculate about twice the time for this action compared to when not using this option. The option can therefore also be switched off (with the value 0).

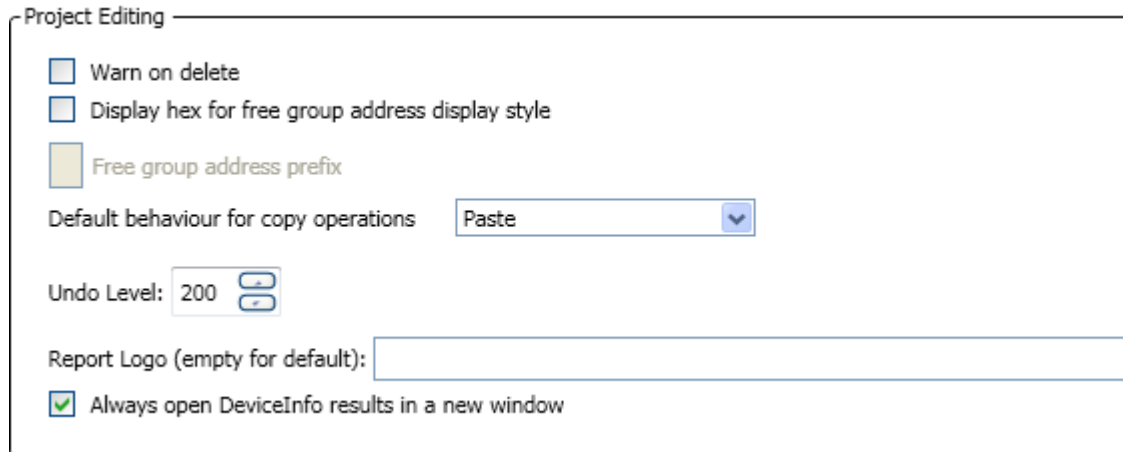

**Figure 38: Setting the Undo Level**

Please also note: This function has global repercussions. The saved working steps can relate to different projects and / or databases: when undoing them, the function will access this data, even if no longer available or no longer opened.

Which options are available?

On the one hand, it is possible to click on the two buttons in the main menu bar. You can however also open the “Undo History” in the “Side Bar” to see what has been saved there. An entire sequence of steps can in this way be reversed or restored in one go - if appropriate. Actions that are greyed out have already been reversed once but can still be restored.

### 8.3 Dynamic folders

The contents of “dynamic folders” can be stored according to specific filter conditions e.g.:

- ✚ Bus devices that still need to be programmed
- ✚ Lines without bus devices
- ✚ Group addresses without object associations
- ✚ Download lists (if you are editing certain devices across all the structures and wish to program them collectively, they are stored in the dynamic folder called “Modified devices”).
- ✚ All bus devices of a specific manufacturer
- ✚ All bus devices which have a switch function
- ✚ .... and much more.

The benefit of dynamic folders is that they are always “up-to-date”.

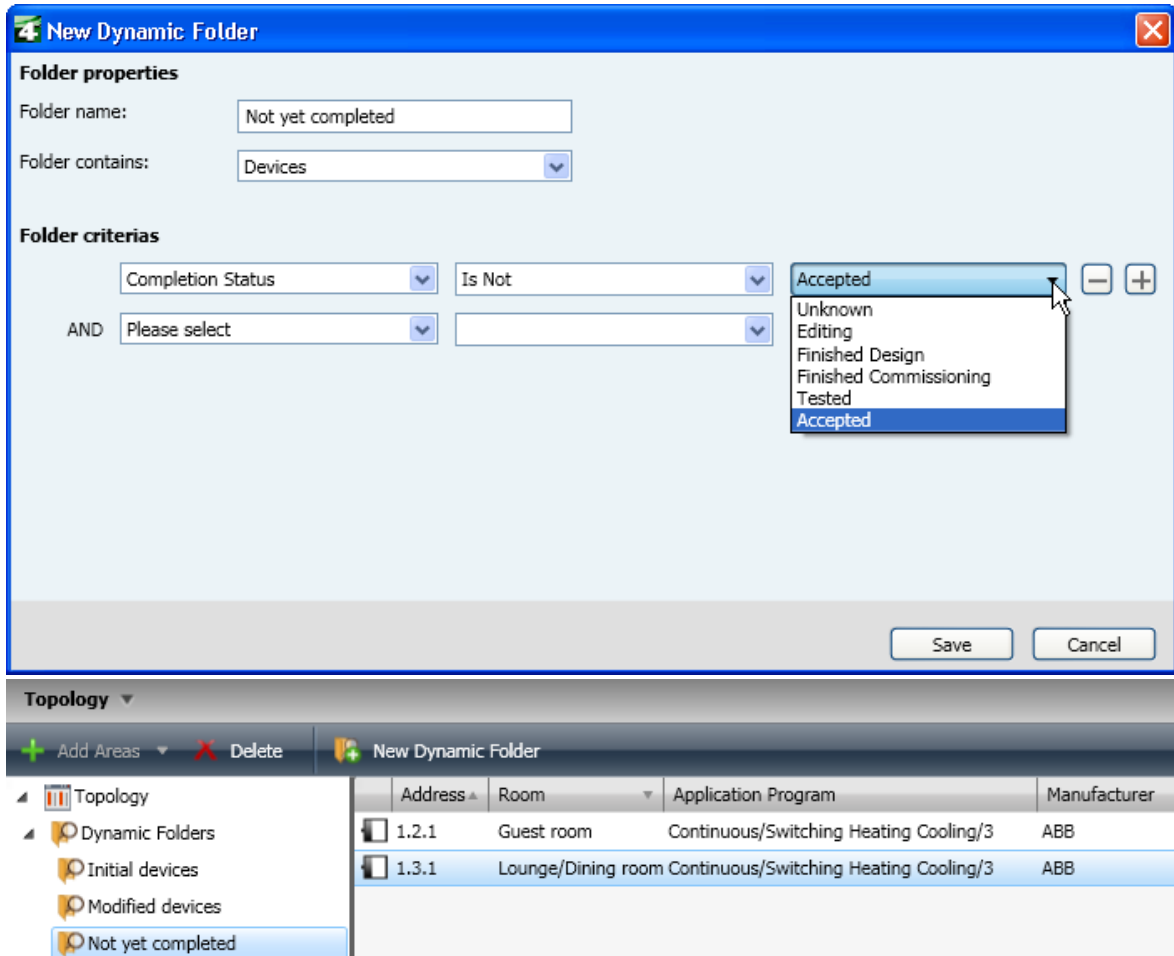
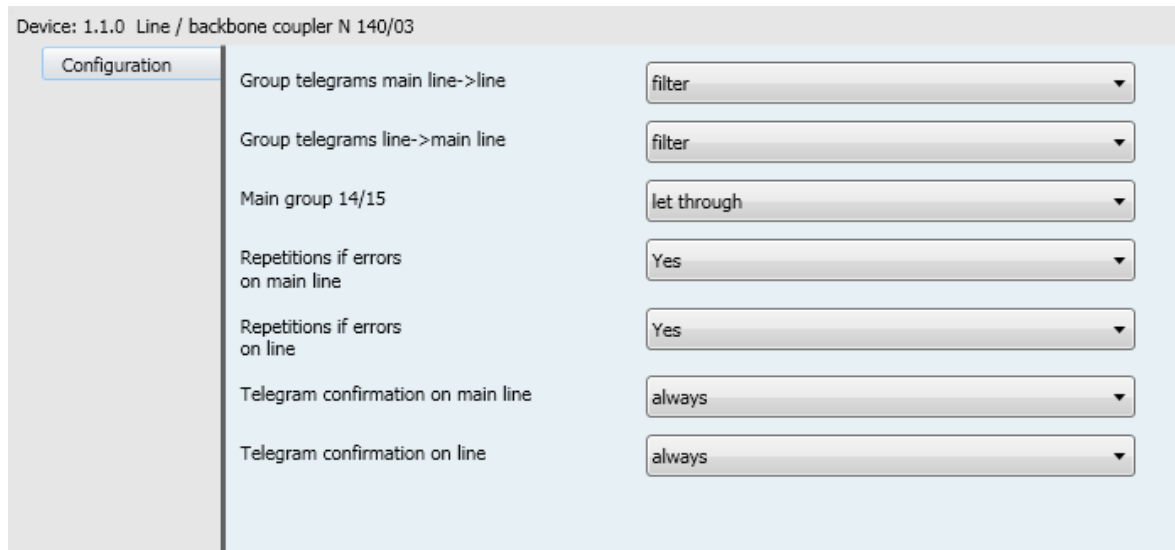

Figure 39: Example of a dynamic folder: all devices whose status is not yet “accepted”

### 8.4 Checking and editing filter tables, permitted group address ranges

Line / backbone / or media couplers must be inserted for logical coupling, as soon as two or more bus lines are created in a project. In order to avoid that group telegrams of one line are sent unnecessarily on another line, each line coupler must be loaded with a filter table. The filter table consists of a bit matrix in the (permanent) memory of the line / backbone coupler. Each bit represents exactly one group address. If the coupler receives a group telegram, it will check in the filter table if the bit has been set for this group address. If so, it will redirect the telegram to another line. If not, it will do nothing.



**Figure 40: Coupler parameters**

All theoretically possible group addresses can now be used in ETS, including the main groups from 16 to 31. The filter tables of the line couplers have however not been extended until now – this is due to the fact that manufacturers preferred to remain compatible with old installations rather than cause possible conflicts. Occasionally a warning is therefore displayed in ETS that main groups above 15 cannot be used. The message shown here refers to a plug-in device; most plug-ins only allow linked products with “regular” addresses < Main Group 16.

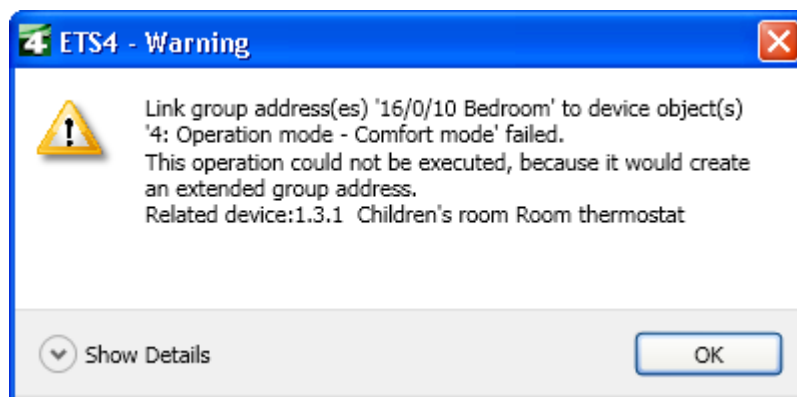

**Figure 41: Warning when using the “high” group addresses**

For test purposes, parameters can be set in such a way that couplers will route or block all group telegrams, whereby both transmission directions Line → main line or vice versa can be set separately. You will find sufficient details about setting the parameters and the function of the coupler in the chapters “Topology” or “Bus devices”.

You will find a detailed explanation in the project design example below as to why filter tables should be activated in normal mode.

#### 8.4.1 Automatic filter table

The project designer does not have to deal with the correct creation of filter tables provided that the project contains all information regarding in- and outputs (=senders and receivers). In this case, ETS automatically generates the correct table. The creation of the

table starts with the download of the coupler. That is why filter tables are not displayed, but are loaded straight away in the coupler.

#### 8.4.2 Manually created addresses in the filter table:

Nevertheless, there are cases, in which the tables cannot be generated correctly because of the fact that devices receive or send telegrams, whose parameters cannot be set in ETS, for instance gateways or visualisation programs. In this case, a solution is needed to correctly set the filter tables, just for these addresses.

There are two options available:

- a) Manual configuration of the filter table
- b) Use of a dummy application

To a): In topology, in addition to the devices created in the line, you can also insert the group addresses which are to be linked manually.

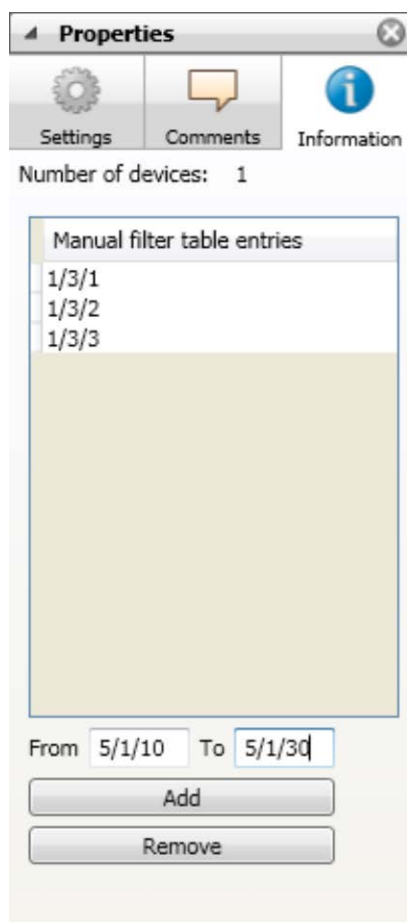

**Figure 42: Manual filter table entries**

You can do so simply by dragging the group addresses from the Group Address view into the Topology view. If you drop them onto a line, the Properties entry “Manual filter table entries” appears.

Alternatively, you can also use the input field “From” and “To” below this list.

This procedure is not appropriate for a larger number of lines, as one personally has to keep track of where group addresses need to be inserted manually.

b) is for sure the better method:

#### 8.4.3 Using a dummy application

A dummy application is set as a virtual placeholder for the real visualisation. In the Topology view, it does indeed look like a bus device but is not really installed. It merely represents a sort of “calculation aid” for ETS for the setting of filter tables. Let us suppose a visualisation needs to be used in main line 1.0. You then insert a dummy application in

this line and link all group addresses used in the visualisation with this application. The great advantage of this application is that it again ensures that all the filter tables in a project are calculated automatically.

A dummy application normally has a very large address capacity and variable object types, so that it is possible to assign any number of addresses.

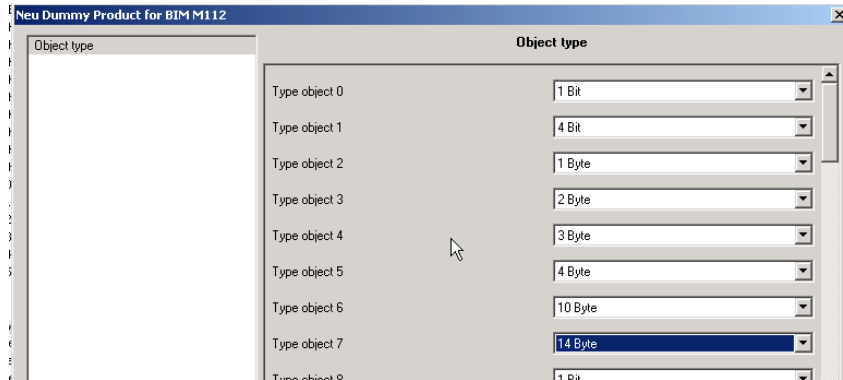

Number	Name	Description	Length
0	1 bit (1)	Switch/Logic	1 bit
16	4 bit (1)	Dimming	4 bit
28	1 byte (1)	Value	1 Byte
38	2 byte (1)	Floating comma 2 byte	2 Byte
48	3 byte (1)	Time, date	3 Byte
51	4 byte (1)	IEE standard	4 Byte
57	8 byte (1)	Min/max values	8 Byte
63	14 byte (1)	Text	14 Byte

**Figure 43: Parameters / objects of the dummy application**

Ideally, this dummy application can have the interface address of the visualisation and an appropriate comment can be entered as device description:

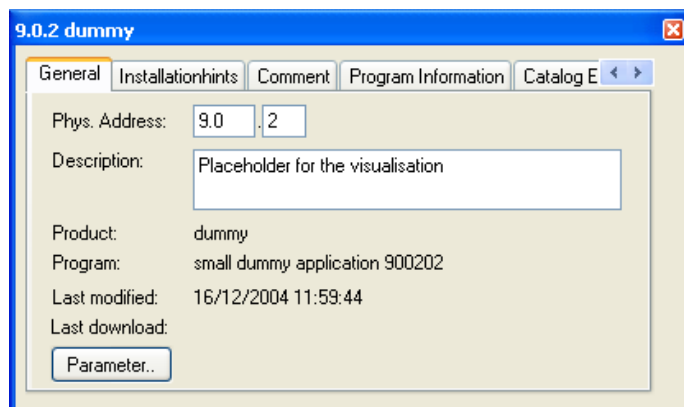

**Figure 44: Dummy product for visualisation**



## 9 Checking the project

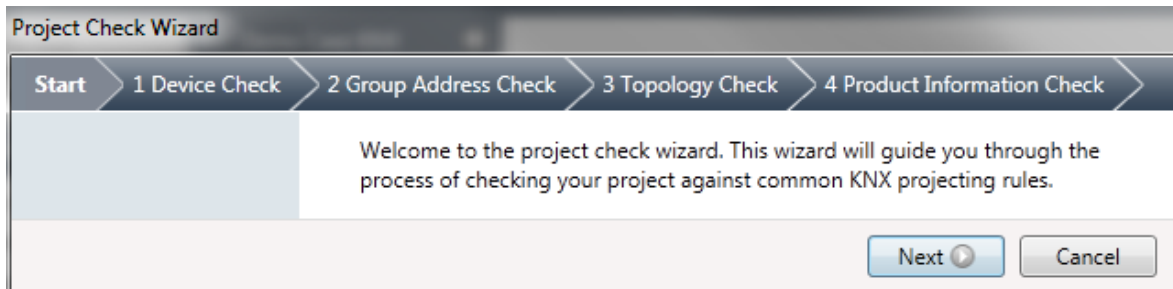

**Figure 45: Structured project check**

After termination of the engineering work on project, before the first commissioning work starts, even before ordering the material, it makes sense to check the whole project structure if all requirements really have been met.

ETS can support here to a limited extent, by means of the integrated, structured checking algorithm.

4 categories of properties are checked:

- a) missing or wrong / wrong number of system devices such as power supplies, chokes, line and area couplers. ETS will show an error for lines that have attributed bus devices but do not have any system devices. Lines without attributed devices are not evaluated → Device check
- b) missing group address assignments (group addresses to device and vice versa). ETS requires that a group address is at least assigned to 2 group objects, and that one bus device has at least 1 object link to a group address → Group address check
- c) missing individual addresses (inserted devices not yet assigned to a line) → Topology check
- d) Product information check

The individual steps in detail:

### 9.1 Device check

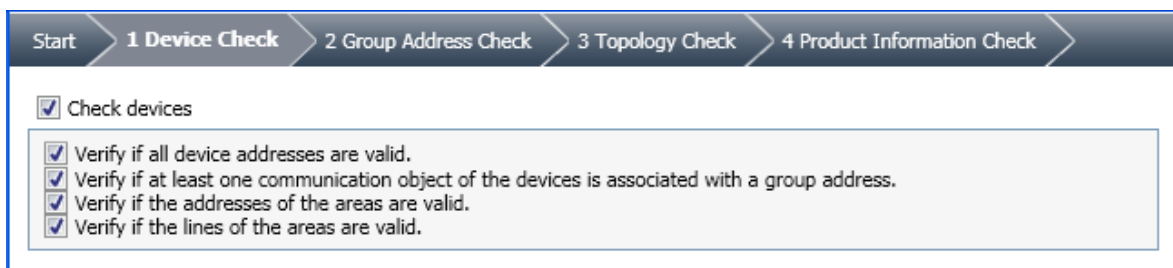

**Figure 46: Device check options**

## 9.2 Group address check

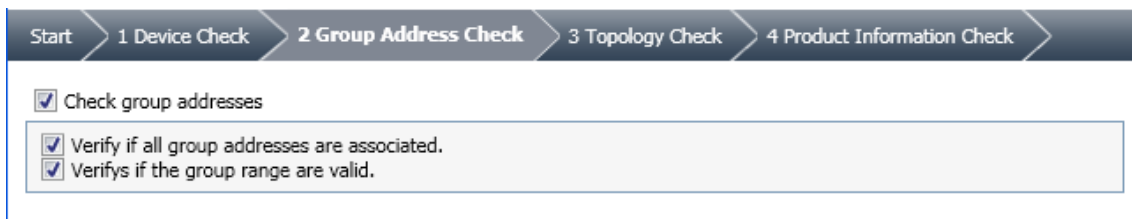

Figure 47: Group address check options

## 9.3 Topology check

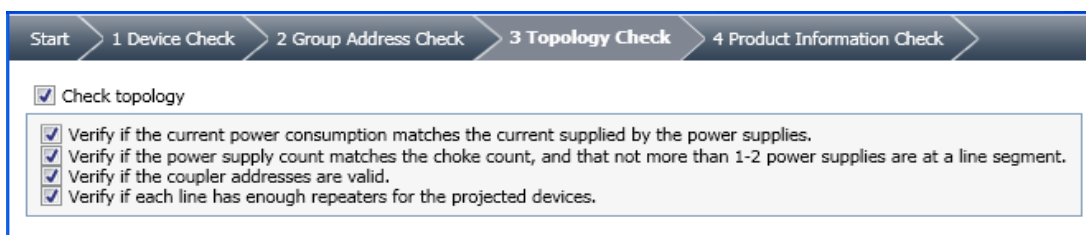

Figure 48: Topology check options

## 9.4 Product information check

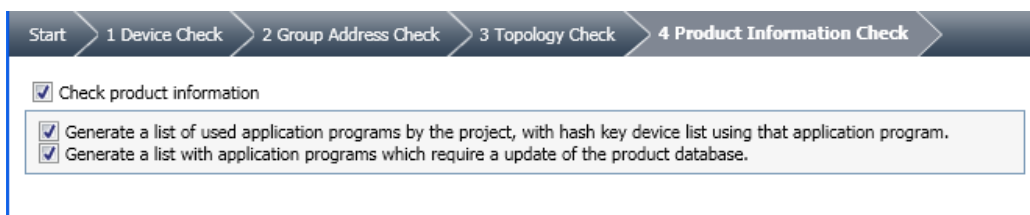

Figure 49: Product information check

The test results illustrate very clearly what is missing or has been forgotten and by clicking on the hyperlinks in the results screen, you can jump to the objects with errors. The product information check is particularly interesting if a manufacturer has several applications per device. The check then shows which update options should be used if possible.

## 9.5 Limits of the ETS project check

ETS can really only detect very rough errors. It is obvious, that such an automated check cannot find logic errors of the project engineer. If e.g. the group addresses have been assigned incorrectly or uncompleted or a device has been assigned to the wrong line, this cannot be detected.

For example, it is also not possible to guarantee that parts lists are complete as accessories such as connectors, data rail, bus terminals and above all bus couplers (for all flush-mounted devices requiring them) can indeed be inserted from the catalog but are not compulsory.

On the other hand, detected but uncorrected errors will not prevent configured bus devices from being downloaded, as long as they have an individual address and the line is powered by a suitable power supply unit.

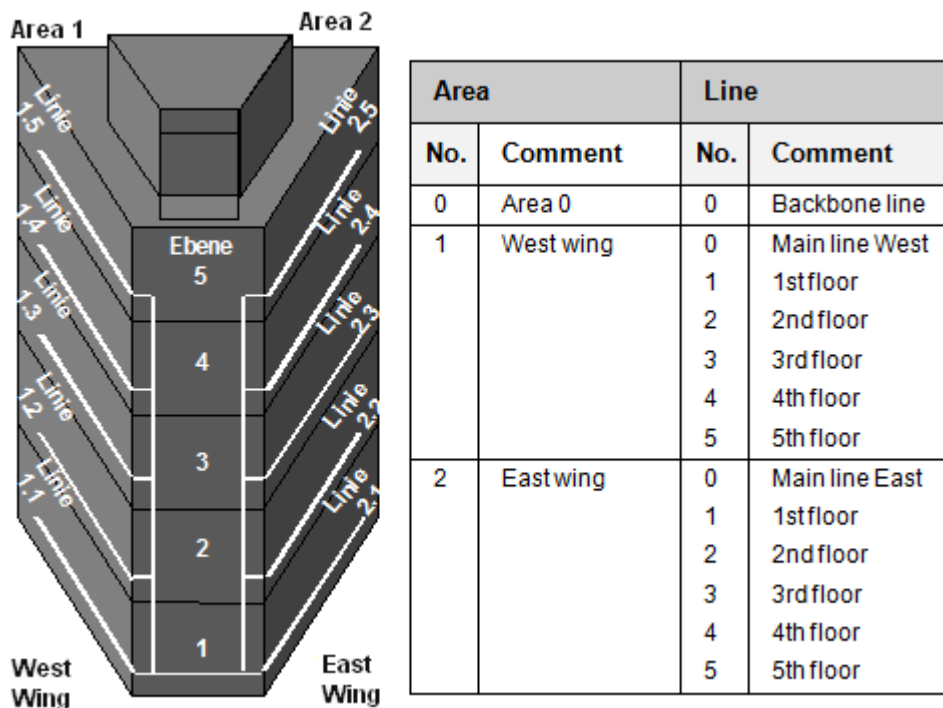

Figure 50: Division of lines in a medium-sized project

## 10 Bus hierarchy

### 10.1 General considerations

Before you finally start the actual ETS project design work, you should have made a rough draft for the later assignment of the bus devices. Assignment means: area and line addressing. Moreover, it is about translating project requirements put forward by the client into the functional scope of the available bus devices. For instance, a requirement could be: "Emergency function for lighting and blinds must be guaranteed in the event of a bus failure". In this case, the corresponding actuators must be selected under these prerequisites. Devices without manual operation are hence excluded right from the beginning. We will deal with this issue later.

If higher data throughput is to be expected, one should contemplate to create TP lines as islands, connected to an Ethernet network via TP/IP routers, which has a significantly higher transmission rate.

### 10.2 Taking the building structure into account

In order to maintain a clear overview, also during later extensions and servicing work, the division of the KNX system into lines and areas should be optimally adapted to the real building structure. The easiest way would be that a building could represent an area and the floors could represent the lines.

If however the number of bus devices that are placed in these individual segments deviates significantly from the requirements regarding cost efficiency, you need to modify the structure accordingly, resulting in the most cost-effective but nevertheless convenient solution.

### 10.3 Inclusion of customer requirements

Client demands can moreover considerably affect the to be installed bus structure. These may include:

- ✚ Actuators should all be principally installed in distribution boards, accessible from the outside in order to reduce interruptions in the event of service and maintenance work.
- ✚ To make cabling easier and therefore have fewer load circuits, actuators should always be installed as close to the load as possible.
- ✚ In larger buildings with standard room types, all bus devices of a room should be installed together in the same environment (e.g. room control box).
- ✚ Instead of perhaps 4-fold or multiple push-buttons, only single or 2-fold push-buttons should be installed, as these are easier to operate and label.
- ✚ The operation costs for bus lines (i.e. supply of energy, uninterruptible power supply and so on) should be reduced if possible, while accepting the disadvantages in terms of safety.

### 10.4 Consideration of system limits, planning of reserves

In order to be prepared for any possible changes in the course of the planning phase and also for the future expansion of the system, you should include reserves in your calculations. In plain language, this means – taking into account the general conditions given above – that a bus segment should be equipped with at least 30 bus devices in the first stage with a maximum of 50. Bus lines can each be supplied with a single or even 2 power supply units or 2 segments can share a power supply unit with 2 chokes. In special cases, even devices with a distributed supply can be used (see chapter ‘Topology’). Please also ensure that the available energy is sufficient for further expansions! It is not always possible to install the upper limit of 64 bus devices, when the current consumption of the devices exceeds the capacity of the power supply unit. On the other hand, a stronger power supply unit (e.g. 1280 mA) cannot guarantee that you can operate 64 devices, as the total impedance of the line is reduced due to the higher total current consumption, thus negatively influencing the signal form and transmission range. Until now, the manufacturers have refrained from providing detailed information on this topic since it is impossible to describe all exceptions and find a reliable functioning solution for each possible case. You are therefore expressly reminded here again, that the limits mentioned in other chapters (64 devices but no more than 640 mA no-load current) must always be respected.

## 10.5 Line coupler or IP router?

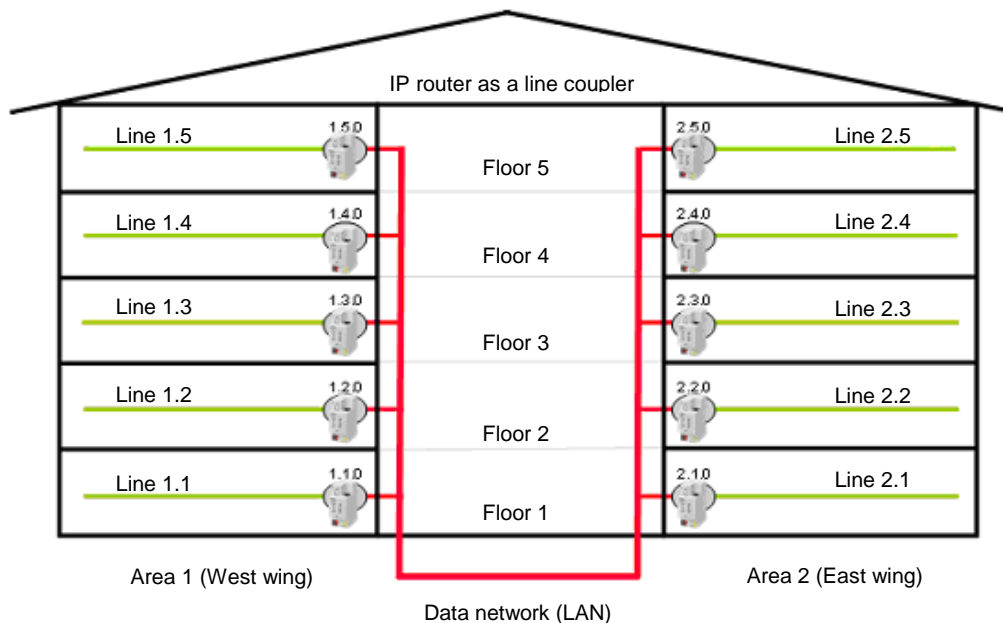

**Figure 51:** IP routers replacing line couplers

For many years now, more and more IP routers are installed, next to the classic TP-TP line couplers. Nowadays, they are still significantly more expensive but offer several benefits that should not be underestimated:

- ✚ In addition to the standard multicast routing function, each IP router offers one or more so-called IP tunneling links.
- ✚ These tunnelling links can be used for ETS remote access as well as for access by visualisation programs.
- ✚ If you access the associated line directly with ETS via an IP tunnelling connection, you always have the fastest possible communication link available.
- ✚ The visualisation can also be made considerably quicker if it can be linked to all IP routers simultaneously via a single data interface.
- ✚ In the vertical communication KNX to Visualisation, speeds of up to factor 225 can be achieved (225 lines in parallel equals  $225 \times 9.6 \text{ kbit/s} = 2.16 \text{ Mbit/s}$ )

In principle one can say that the more lines that are needed and the more data points that are centrally monitored, the more worthwhile the use of IP routers becomes.

## 10.6 Data rates and cyclical processes

The data rate, which can occur on average or in critical cases, should also be calculated right from the beginning. Time-critical functions requiring a quick reaction (real-time applications) should if possible not be planned and designed across lines. In this case valuable tenths of seconds could be lost when passing through line/backbone couplers. This applies to dimming, especially cyclical dimming. If such local functions are realized across several couplers, this will affect the linearity of the variation of light intensity. Moreover, the start and end delay of the function may in some cases be too high.

You should also pay attention to the total data rate for all devices with cyclical sending. Cyclical transmitters are all alarm sensors (e.g. wind and rain detectors, weather control units, smoke detectors, window contacts), which should be continuously monitored to ensure that they are functioning correctly.

The security level of the bus system does not always increase when setting such a device to “sending” as often as possible, but more by choosing a rate that is adapted to the potential bus load.

Even more critical are devices and software packages that cyclically poll the status of their communication partner. The fact is that this will result in at least two bus telegrams per data point –the polling telegram as well as the corresponding answer.

In addition, normal bus load can be endlessly “increased” by incorrectly configured line and backbone couplers. The following section will outline an example, taking into account the aspects mentioned above. It shall however be noted that with this example is only able to touch upon a small proportion of all possibilities of a flexible and variable system as KNX!

Further below (11.3), you can find a calculation example for planning or calculating bus telegram loads.

## 11 Planning a project: Example

### 11.1 Requirements / regulations (specification text)

A bus line contains the equipment of a floor with 8 rooms. The functional requirements for each individual room are:

- ✚ 3 dimmable lighting circuits; 4 x 58 W; can be manually switched both separately as well as together, changeover switch to automatic operation
- ✚ 2 shutters, proportionally adjustable, can be manually controlled both separately as well as together
- ✚ 1 radiator, with proportional control and the corresponding heating controller
- ✚ 2 window contacts, which lower the temperature when the windows are opened
- ✚ 1 room information and control panel, displaying the functions and values of the temperature controller (setpoint and current temperature, night/day operation mode), indicating storms and displaying the state of the shutters and lighting control (manual/automatic) and also allowing to control the latter
- ✚ for the operation 2-fold or 4-fold push-buttons, also realizing a central function: basic lighting (2 of 3 strips of lights) on; all lights off + shutters up.

Moreover, a weather control unit is used, which amongst other things has the following functions for the rooms:

- ✚ Wind sensor: raising shutters in the event of a storm
- ✚ Light sensor: when a pre-determined brightness limit is exceeded, closing of shutters, switching on lighting control and proportional control of slats, raising the shutters at nightfall

In addition, a central time switch is used, which

- ✚ controls the room temperature profile centrally on a weekly basis
- ✚ switches off lights at night when still turned on

An information panel is used per floor, which displays for each room

- ✚ whether a window is opened
- ✚ current temperature values and setpoint
- ✚ whether a light has been left on somewhere
- ✚ position of shutters (has limit of 30% been exceeded?)

On a summary page for each floor, the following should be displayed:

- ✚ at least 1 window open – yes/no?
- ✚ at least 1 light on – yes/no?
- ✚ at least 1 shutter lowered (more than 30%)?

In order to generate group signals, appropriate logic modules must be used. The automatic slat function depending on external brightness is implemented stepwise (3 steps) by means of an analogue threshold value converter.

All status signals – including the group signals – should run centrally in a building visualisation.

## 11.2 Task definition

Now, you have to assess, if

- ✚ one bus line segment is sufficient or if two are needed
- ✚ which bus telegram load can be expected?

The underneath explanations show that this assessment can lead to substantial differences, which can influence the success and failure of the KNX technology.

You can now use ETS first in order to select possible bus devices:

From the great quantity of available devices, the following could have been selected:

### 11.2.1 Parts list for solution 1:

Per room:

- 3 switch/dimming actuators (1-channel)
- 1 brightness controller
- 1 valve drive
- 1 contact interface with 2 inputs
- 1 heating controller
- 1 display with at least 6 display functions
- 1 x 2-channel shutter actuator
- 4 x 2-fold push-buttons
- 1 logic module for the light/shutter group signals
- 1 logic module for the connection of the window contacts

---

15 devices

x 8 = 120 devices

In addition:

- 1 logic module for the conversion of analogue threshold values into binary signals (shutter)
- 3 logic modules for - all windows, - all shutters, - all lights
  
- 1 information panel
- 1 time switch
- 1 weather control unit

---

***makes exactly 127 devices***

***When taking into account the reserves, 2 lines and a main line are therefore necessary***



The following solution would however also be possible:

### 11.2.2 Parts list for solution 2:

Per room:

- 1 x 3-fold switch/dimming actuator with integrated brightness controller
- 0.25 x 8-fold shutter actuator (used for 4 rooms)
- 1 valve drive with 2 integrated contact inputs
- 1 heating controller with integrated 2-fold push-button
- 1 x 4-fold push-button
- 1 display with at least 8 display and operating functions

---

Total per room 5.25 devices x 8 = 42!

In addition:

- 1 logic module for the conversion of analogue threshold values into binary signals (shutter)
- 1 logic module for all binary connections for the group signals
- 1 weather control unit (as above)
- 1 information panel (as above)
- 1 time master (because the time clock functions can also be detected by the analogue threshold value generator, when it receives the time on a regular basis).

---

***This totals only 47 bus devices! Only 1 line remains, instead of 3 as in the first case!***

***Conclusion:*** Through an accurate survey to determine which optimum device configuration is possible, you can save up to 50% of the costs!

Presuming that solution 2 is implemented, we now proceed to the second part of the study:

### 11.3 Determining the bus loads

#### 11.3.1 Scenario 1:

According to the parameterisation of the components, the specified functions can lead to a noticeable telegram load on the planned bus line.

Status signals that are sent automatically in a 3-row lighting circuit with a sampling rate of one 1 second, also generate between 3 and 6 telegrams (!) per second. That makes 3x the 8-bit brightness value + (when switching on/off) the 1-bit switching state. We know that there can never be more than approximately 48 telegrams per second and with maximum cable length only 24 telegrams per second (the latter is however not the case here). However, we have 8 lighting circuits. If you multiply this with the numbers above, this already results in 48 in the worst case. However, many other bus devices also send out telegrams simultaneously on a regular basis! The scenario could look like this in the worst case:

- ✚ Each room display unit polls the status 1x per minute (6x) = 12 tel./min.
- ✚ The logic module (56 inputs) is also set to cyclical polling of all inputs, with an interval of 30 seconds per polling cycle = 224 tel./min.
- ✚ The analogue threshold value converter polls 16 (shutter) states 1x per minute (= 32 tel./min.)
- ✚ The building visualisation polls the state 1x per second (= 120 tel./min.)
- ✚ The wind sensor sends 1x per minute (= 1 tel./min.)
- ✚ The brightness sensor sends 1x per minute (= 1 tel./min.)
- ✚ The floor information display polls up to 10 states every 10 seconds (= 120 tel./min.)

	B	C	D	E	F	G	H	I	J	K	L	M	N
1													byte_time
2	Determining the bus load												1.35 ms
3													
4	for line	1.1	Total time			41.6556	Bus load (%)		Telegram types				
5						sec	69.43%						
6	Device	Address	Type	Tel pro min	Number	Query = 2, otherwise 1	Time	Total time/min		Bytes	Length	Time	Type
7	Info display	1	2	1	6	2	21.6	259.2		1-6 bit	15	20.25	1
8	Logic module	2	1	2	56	2	20.25	4536		1 byte	16	21.6	2
9	AS/U	3	2	1	16	2	21.6	691.2		2 byte	17	22.95	3
10	Building vis.	4	1	60	1	2	20.25	2430		3 byte	18	24.3	4
11	Wind	5	1	1	1	1	20.25	20.25		4 byte	19	25.65	5
12	Brightness	6	3	1	1	1	22.95	22.95		6 byte	21	28.35	6
13	Floor info	7	2	60	1	2	21.6	2592		8 byte	23	31.05	7
14	Bright. controller 1	8	2	60	3	1	21.6	3888		10 byte	25	33.75	8
15	Bright. controller 2	9	2	60	3	1	21.6	3888		14 byte	29	39.15	9
16	Bright. controller 3	10	2	60	3	1	21.6	3888		<b>Result</b>			
17	Bright. controller 4	11	2	60	3	1	21.6	3888					
18	Bright. controller 5	12	2	60	3	1	21.6	3888					
19	Bright. controller 6	13	2	60	3	1	21.6	3888					
20	Bright. controller 7	14	2	60	3	1	21.6	3888					
21	Bright. controller 8	15	2	60	3	1	21.6	3888					

Figure 52: Spreadsheet in EXCEL for determining the bus load / transmission time per minute

These were by far not all of the telegrams sent on this bus line, only those that were created by the automatic control loops and those devices returning statuses. Nevertheless, the 7 points listed above result in a total of 502 tel./minute or 8 –9 tel./sec., which represents a **bus load of approximately 20%! Together with the lighting control** without modification of the switch status, this already amounts to **70%!**

### 11.3.2 Always set the line/backbone coupler to “filter”!

The following however adds to the problem: (unfortunately quite frequently) the filter tables of the line/backbone coupler are made “inactive”, by setting the standard parameters from “filter” or “normal” to “route everything”. This can lead to a serious problem. This leads to the following estimate:

The system above exists exactly twice. Both lines are connected via the main line, in which the weather station and the visualisation are located. The couplers are “unlocked”, i.e. they let all group telegrams through unfiltered.

Now the following happens: all telegrams listed above are also channelled in the neighbouring line and vice versa. However, in this line there is no receiver. Consequence: The coupler repeats these telegrams after the initial transmission another 3 times. If bus loads above 100% were possible - we already reached 100% without lighting control – this would theoretically result in 350% bus load with lighting control. This is of course limited to 100% and as a consequence frequent losses of telegrams and delays when transmitting.

ETS supports quick calculation as well as optimized short download of filter tables: they are constantly updated in the background; only bytes that differ from “00” are taken into account when downloading the coupler. This process is made possible by a fast-erase algorithm, which first sets the old filter table to “zero” before the new one is loaded.

Now it still needs to be verified whether the cyclical polling intervals need to be as short as mentioned above or whether cyclical polling is necessary at all. Let us look at an alternative:

### 11.3.3 Scenario 2:

Underneath another solution that offers almost the same security, but a substantially lower bus load: (we assume that all changes to the corresponding bus devices are sent automatically and that they basically do not need to be polled at all)

- ✚ The 8 lighting controllers now only poll every 5 seconds = max. 576 tel./min. (or 288 without change in the switching state)
- ✚ The room information displays poll 1x every 5 min. (= 2.4 tel./min.)
- ✚ The logic module now only polls every 5 min. as an additional security measure (=22.4 tel./min.)
- ✚ The analogue threshold value converter also polls every 5 min. as an additional security measure (=6.4 tel./min.)
- ✚ The visualisation does not poll at all, as all important information is already either sent event driven by the bus devices themselves in the line or is additionally polled (= 0 tel./min.)

✚ The floor information display now only polls 1x per minute (= 20 tel./min.)

**Result now: 627 tel./min. or 339 tel./min. or approx. 11 (22%) or 6 (12%) tel./sec.**

The difference is remarkable! What is more, not one function is unacceptably delayed, and all signals are generated immediately as before! It is still possible to reduce this rate even further, how can be determined by the reader himself, in accordance with the here outlined specifications.

Determining the bus load							
for line	1.1	Total time			7.33968 sec	Bus load (%) 12.23%	
Device	Address	Type	Tel pro min	Number	Query = 2, otherwise 1	Time	Total time/min
Info display	1	2	0.2	6	2	21.6	51.84
Logic module	2	<b>1</b>	<b>0.2</b>	<b>56</b>	2	20.25	453.6
AS/U	3	2	0.2	16	2	21.6	138.24
Building vis.	4	1	0	1	2	20.25	0
Wind	5	1	1	1	1	20.25	20.25
Brightness	6	3	1	1	1	22.95	22.95
Floor info	7	2	10	1	2	21.6	432
Bright. controller 1	8	2	12	3	1	21.6	777.6
Bright. controller 2	9	2	12	3	1	21.6	777.6
Bright. controller 3	10	2	12	3	1	21.6	777.6
Bright. controller 4	11	2	12	3	1	21.6	777.6
Bright. controller 5	12	2	12	3	1	21.6	777.6
Bright. controller 6	13	2	12	3	1	21.6	777.6
Bright. controller 7	14	2	12	3	1	21.6	777.6
Bright. controller 8	15	2	12	3	1	21.6	777.6

**Figure 53: Spreadsheet in EXCEL for determining the bus load / Scenario 2**

## 11.4 Summary of the bus load calculation

### *If we should draw a conclusion here again:*

The optimum function of the KNX network depends directly on the most accurate estimation of the data rate in the most unfavourable and average condition. You should always take into account, that the bus system is first and foremost event-driven and cyclical repetitions of unchanged states are only necessary as back-up functions with a relatively long time interval.

Lines or backbone couplers shall be set to “normal” mode, when normal operation is adopted, i.e. the filter tables must be loaded, and the evaluation algorithm for the filtered transmission must be activated.

## 12 Administration functions, project documentation and archiving

### 12.1 Reports

In order to document a project, a series of reports are at your disposal.

There are different perspectives to create documentation:

- a) Building structure with allocated devices
- b) Parts list (important for orders!)
- c) Bus topology overview
- d) Detailed lines and device lists
- e) Group addresses
- f) Commissioning status

A detailed printout of the Building View with all available information would already be sufficient in theory. However, it would be very difficult to quickly find out from this report - purely arranged according to the building structure - information for instance about the equipment of a bus line, about the whole topology structure and about the number and structure of the group addresses used. The information as to which devices was downloaded and with which result can also not be deduced from that.

The device details, i.e. configuration of flags, object flags, comments and assigned addresses, should not be printed out in the Building View but in a detailed line printout.

### *How to proceed?*

It shall be first noted that ETS reports always produce a global view of the project. Print outs of certain parts of the installation are only possible via partial printouts or by exporting to a file format other than ETS (see below).

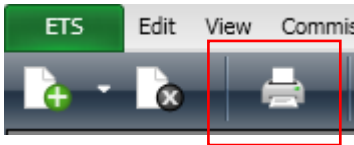

**Figure 54: Starting the documentation tool**

Currently only the here displayed toolbar icon is available for accessing the printing and report generation window.



**Figure 55: Report dialog**

The process is clear: you select a report (on the left-hand side) and press the button “Generate Report”. The preview is thereby created, which can then either be saved as a PDF file or printed out.

Examples:

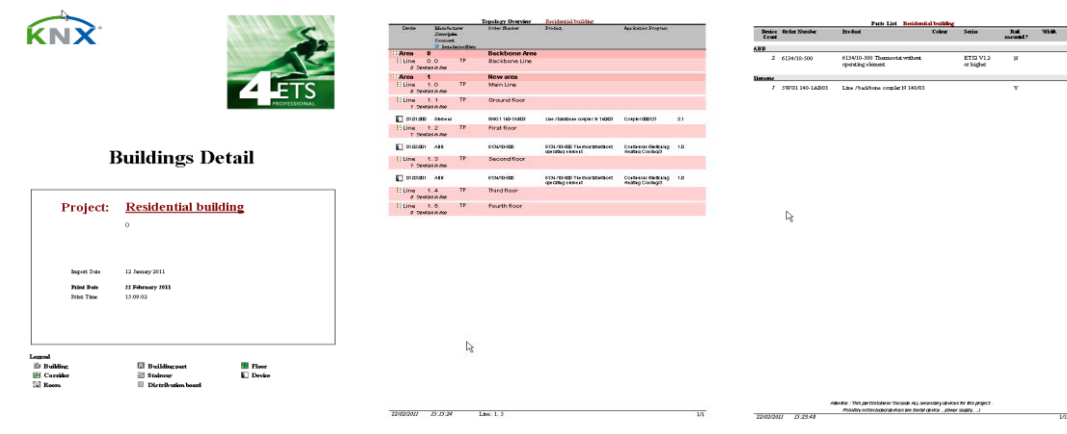

**Figure 56: Building details – Topology overview – Parts list**

## 12.2 Exporting group addresses

Group addresses can be exported in different text formats for processing outside ETS. To do so, click in the Group Address window with the right mouse button on the “Group Addresses” header and then on “Export Group Addresses”. Then select the CSV format and the most suitable delimiter. As tabs are not part of text descriptions, they are the most suitable delimiter to use. In order to be able to edit or expand well the data later on in EXCEL, you should also select the format “3/3” and “Export with header line”.

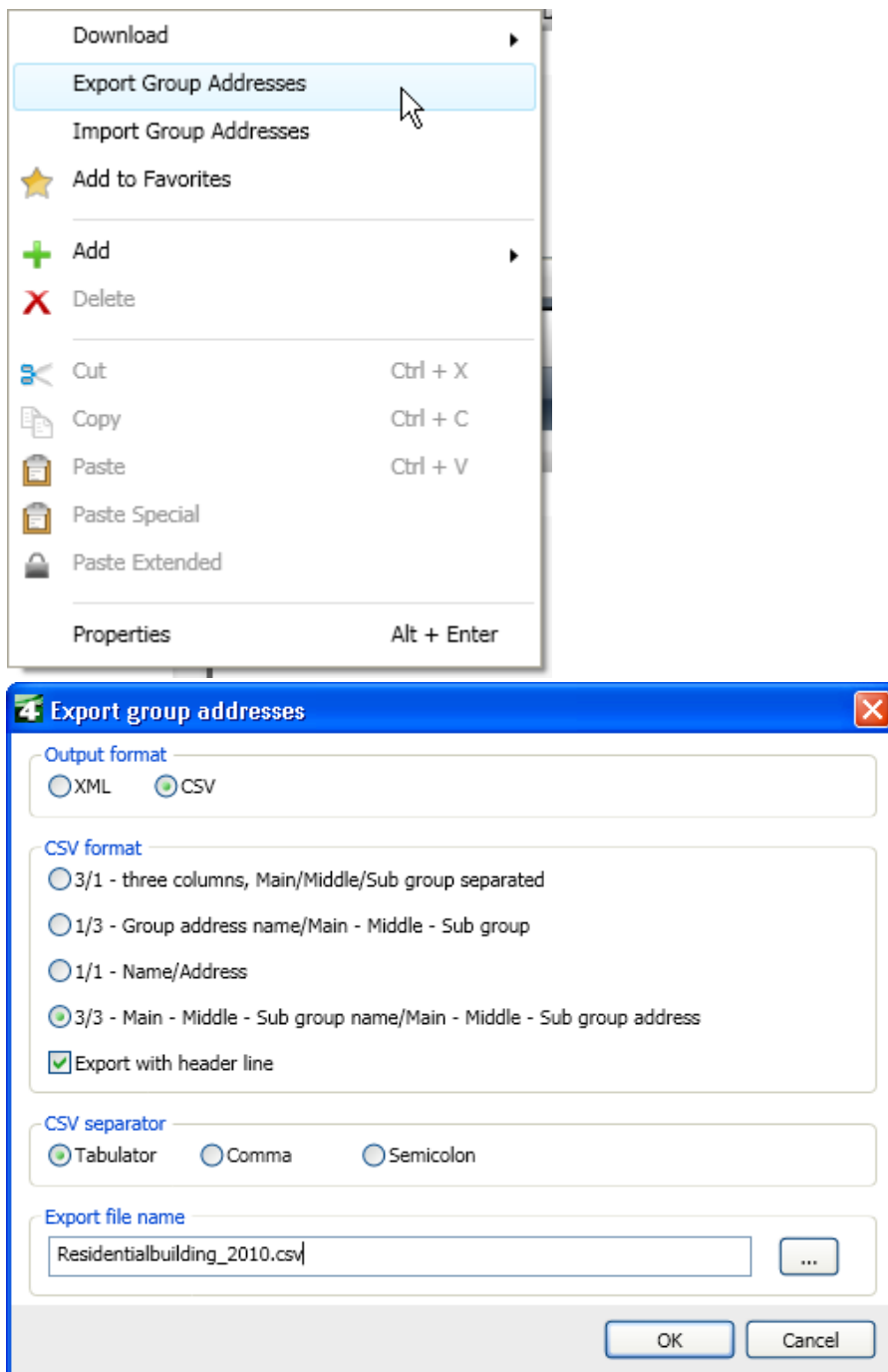

Figure 57: Export of group addresses as a CSV file

Result in Excel:

	A	B	C	D	E	F
1	Main	Middle	Sub	Main	Middle	Sub
2	Training demo case			1		
3		Logic	DALI ECG 8 bit	1	5	5
4				1	6	
5			Time trigger clock	1	6	0
6			Bright/dark	1	6	1
7			Select A	1	6	2
8	Studio			3		
9		DALI lighting		3	0	
10			DALI 1-1 on/off	3	0	1
11			DALI 1-2 on/off	3	0	2
12			DALI 1-3 on/off	3	0	3
13			DALI 2-1 on/off	3	0	4
14			DALI 2-2 on/off	3	0	5
15			DALI 2-3 on/off	3	0	6
16			DALI 1-1 dim	3	0	11
17			DALI 1-2 dim	3	0	12
18			DALI 1-3 dim	3	0	13
19			DALI 2-1 dim	3	0	15
20			DALI 2-2 dim	3	0	15
21			DALI 2-3 dim	3	0	16

Figure 58: Group addresses - Export data in Excel

## 12.3 Export OPC

Many KNX installations are also equipped with a SCADA system (=visualisation). The OPC server is increasingly used to display central system-independent data or to operate functions.

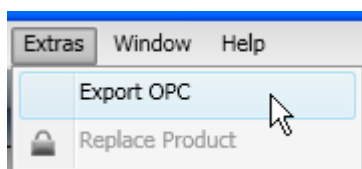

Figure 59: Data export

In most cases, current building management systems use more than one communication system. Apart from KNX, other field bus systems are used for different tasks. On the processing and management level, it should however be possible to link and present all data together. The operating and monitoring programs that are used here (SCADA software) do not have special “low-level” data exchange drivers in order to communicate directly with the relevant bus system, but use a so-called OPC server. (OPC **O**bject **L**inking & **E**MBEDDING for **P**rocess **C**ontrol). The OPC standard defines the most important data types, which are identical in all systems. For instance, data types that can be presented in a 1 bit, 8 bit, 16 bit and 32 bit format. The OPC servers are driver programs, which on the one hand guarantee bus access via the available interfaces (for KNX: RS232, FT 1.2, IP or USB) and on the other hand, if possible, convert the data that is sent or received, in such a way that it can be clearly understood and interpreted on both sides. These programs can be implemented either on standard PCs or in special



hardware with direct bus access. In the case of hardware-based OPC servers, the data exchange nowadays is ensured via an IP network; in the case of software-based OPC servers, it is generally the same, but they can of course also run directly on the server PC, on which the SCADA software is installed.

How can data from a KNX system get into the SCADA software?

It is not possible to use the export function of group addresses as outlined in 12.2, as the data types are missing in this case. ETS however offers you an easy way to first export the complete project data in the appropriate OPC format. The export contains related to group addresses:

- ✚ Name of the main group
- ✚ Name of the middle group
- ✚ Group address (2 or 3 levels)
- ✚ Name of the subgroup
- ✚ Data type (EIS data type)
- ✚ Priority (this is important for sending telegrams via the OPC server)
- ✚ All other group addresses, which can be influenced directly or indirectly via device objects (e.g. all separate functional addresses in case of central addresses. This ensures that when operating a central command, the correct value will also be assigned to all separate functions).

This file is created in ASCII format – format with the extension “ESF” (=EIB Session File) and can thus not only be read from an OPC server (an additional program, which can be obtained from KNX members), but also from any other appropriate server program, which understands this format.

```

Training Kit visualisation(2)
Umweltmesswerte.wetterstation.4/0/0    Außenhelligkeit    Uncertain (2 Byte)    LOW
Umweltmesswerte.wetterstation.4/0/1    windgeschwindigkeit    Uncertain (1 Byte)    LOW
Umweltmesswerte.wetterstation.4/0/2    Luftfeuchte        Uncertain (1 Byte)    LOW
Umweltmesswerte.wetterstation.4/0/3    Außentemperatur    Uncertain (2 Byte)    LOW
Umweltmesswerte.wetterstation.4/0/4    Innentemperatur    Uncertain (2 Byte)    LOW
Umweltmesswerte.wetterstation.4/0/5    Schwelle 1 Downlights    EIS 1 'Switching' (1 Bit)    LOW    1/0/10 1/0/3 0/0/1 0/0/50
Umweltmesswerte.wetterstation.4/0/6    Helligkeitssensor e/a    EIS 1 'Switching' (1 Bit)    LOW
Umweltmesswerte.wetterstation.4/0/7    Schwelle 2 Strahlerbel.    EIS 1 'Switching' (1 Bit)    LOW    0/0/1 1/0/21 1/0/40 0/0/60 1/0/23 1/0/41
Umweltmesswerte.wetterstation.4/0/8    windalarm 16 m/s    EIS 1 'Switching' (1 Bit)    LOW    4/0/9
Umweltmesswerte.wetterstation.4/0/9    Regenalarm (N670)    EIS 1 'Switching' (1 Bit)    LOW    4/0/8
Umweltmesswerte.wetterstation.4/0/10   windalarm 10 m/s    EIS 1 'Switching' (1 Bit)    LOW

```

Figure 60: Export file contents

## 12.4 Data types

The already discussed data types (display format of the data) can be checked and also changed in ETS. You should clearly make the distinction between pure information (number of bits) and their interpretation (formatting, translation). In order not to create any non-practice-oriented restrictions, all group objects of KNX devices with the same data size can be linked to each other via group addresses. A functional unit, which for instance creates threshold value switching telegrams from the information of analogue value sensors, does not have a default data type for its associated objects.

The relevant objects of most KNX devices do not have a data type set by default. If you manually change these settings, they will only affect the relevant object to which the change is made. What is this used for?

- When exporting data (group addresses), this additional information can be of importance later on;
- When recording data with the telegram recorder, the values are displayed correctly.

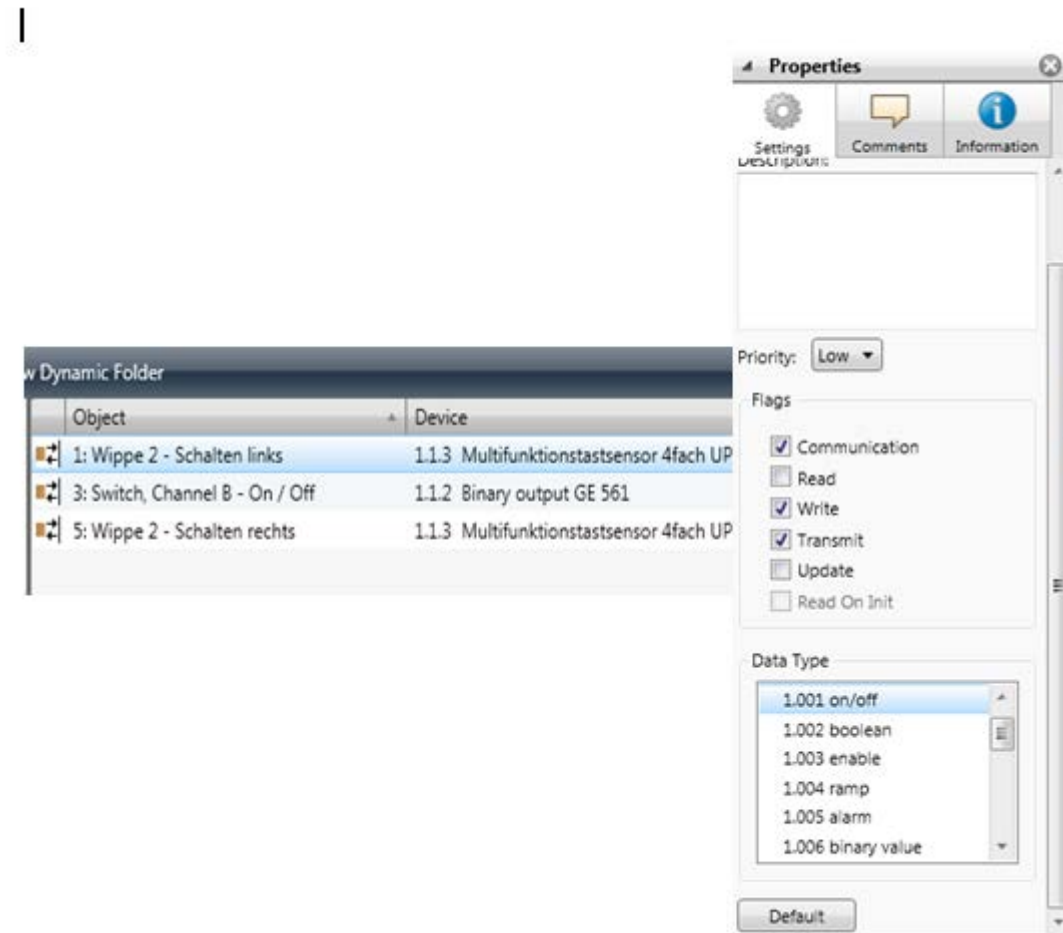

Figure 61: Object data types in the Properties dialog

## 13 Database handling, project backup

### 13.1 General

Managing data correctly is essential to any professional company nowadays. Also for KNX projects, possibilities exist to save them in such a way, that they are largely protected against data loss or damage, particularly while editing the project.

### 13.2 Using one database per project

When you start working with ETS, one normally starts by importing all possible product databases of the different KNX manufacturers. This however produces very large databases. The result is that the reaction speed of these databases decreases as the number of products increases. Moreover, it is not advisable to use a single ETS4 database, as all data would be lost in the case of a database crash.

The best procedure is

- ✚ defining per project which products should be used
- ✚ importing these products into a project-specific ETS4 database
- ✚ in this way you kill two birds with one stone: you produce a small, slimline database that is quick to edit, while also restricting any possible losses to one single project.

### 13.3 Creating regular backups

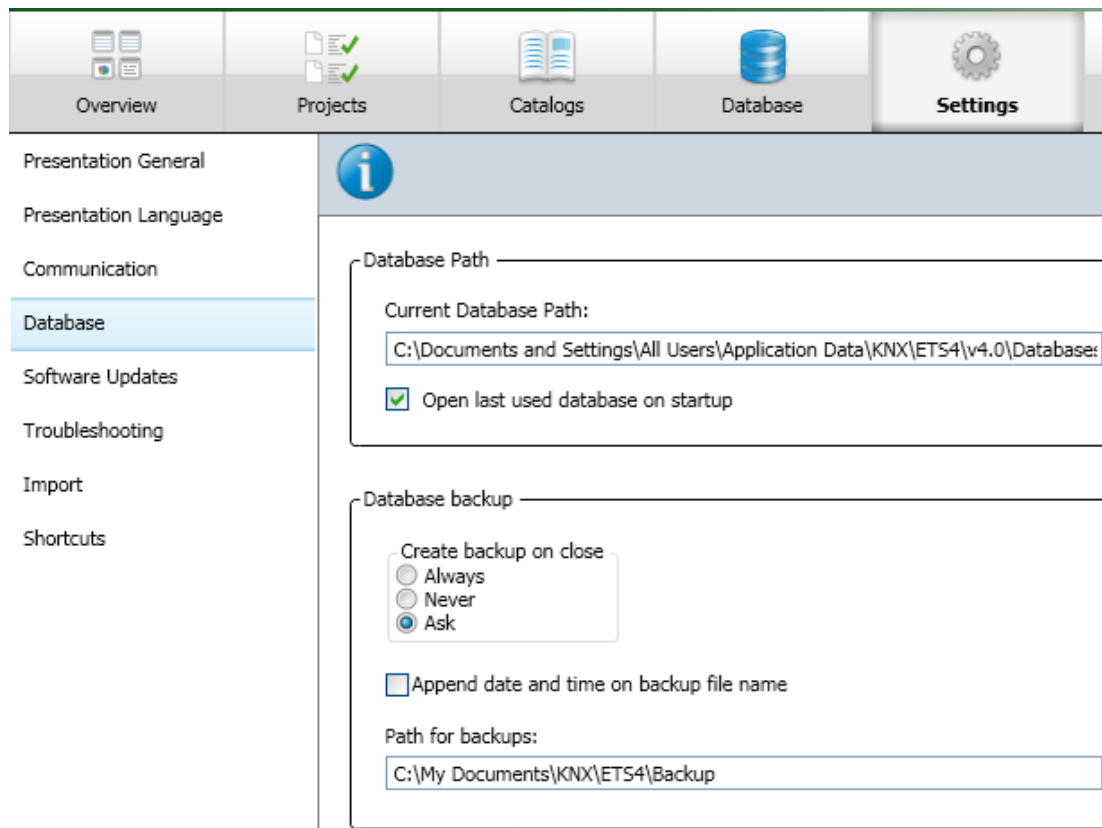

**Figure 62: Database backup settings**

In addition to the usual project export, ETS of course offers data security via backup and restore. This backup can be carried out automatically and with a date and time stamp, the latter ensuring that a new file is created each time ETS is closed. This method does however require a great deal of space, therefore only applicable when working according to the option as set out in the above clause 13.2.

If the backup path points to a central data server, which is in itself regularly backed up, you also have additional security.

### 13.4 Master database and project reconstruction

In order to check specific device functions and parameters quickly, it is advisable – in contrast to the recommendation under 13.2 for individual projects – to create a database with all products one regularly works with. This database is used for reference purposes and not for project design. It has the benefit that you can put it to good use if you have to reconstruct a project at a later date as it contains a large number of products. A

reconstruction via a supplementary ETS function (currently not yet available in ETS4) requires this product data to restore the project.

### 13.5 Central database memory and master database

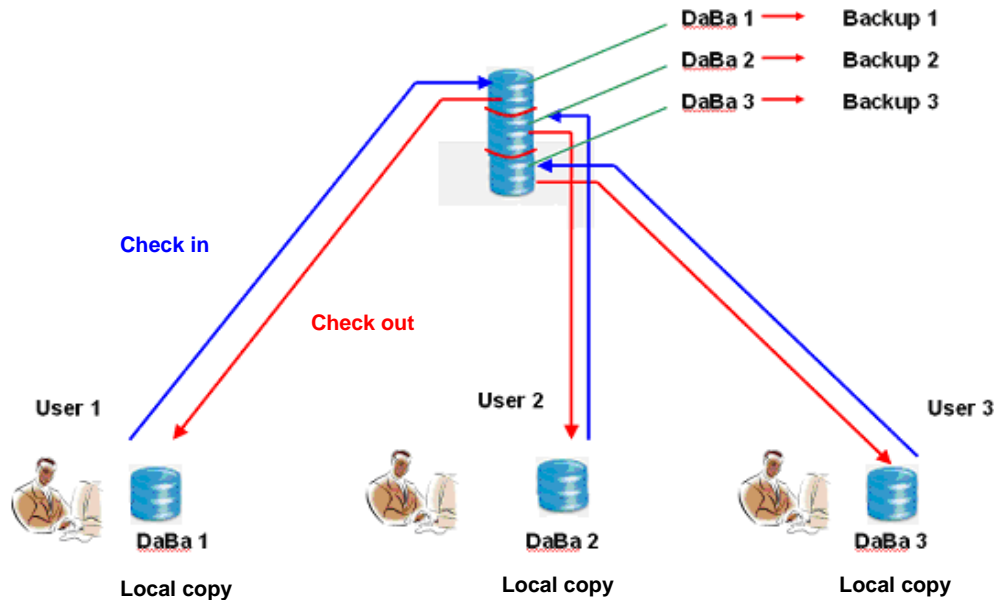

Figure 63: Example of central database management

The central data server mentioned above is also essential for workgroups. All project databases can thus be managed comfortably and edited by all employees and copied back again. This process is called “checking out” and the opposite is “checking in”. If a database is only located on the central server, it is called “checked in”. If a project engineer retrieves the database for editing, it is “checked out”. The checked out database can only be edited by one person; however at that moment a copy is kept on the central server in the form of a backup. This can be restored if the local copy gets lost.

However it is no longer possible to match a restored backup database with the checked out original!

## 14 Complete project documentation

Which documentation should be drawn up by the contractor? When can documentation be considered complete? What is the customer entitled to? And when?

These questions are regularly asked by many training participants. However, also in this case there is no standard answer. You can however at least refer to the relevant regulations and ordinances, which define an approximate scope of the documentation to be provided. In the end, it is always the duty of the parties under contract to define at the initial planning and design stage and before the placing of the order, what constitutes a completely delivered “work”.

The following text was written based on the German “VOB” (a volume of contracting procedures for building works). The author assumes that these national regulations also apply in other countries.

## 14.1 Guidelines according to the German contracting procedure for building works (VOB)

The following text describes the situation in Germany:





Part A of the VOB, § 9 “Work specifications” and § 10 “Submittal documents”, refers to the “documentation” according to §10 sect. 4 (1). In the VOB, Part B, reference is made in §1 “Type and scope of the activity” to the fact that it initially depends on the contract between the contractor and the client. If there are inconsistencies in the contract, all the available documentation – ranging from the technical specification as a basis for the specific and additional contract conditions to the technical contract conditions in accordance with the VOB, Part C – is then used for clarification purposes. This means in plain text that the work specification can already contain information directed at the later implementation of the documentation and in case of doubt can also be used to assert the rights of the client. An interesting factor in this context is represented by §3 no. 6 of the VOB, Part B: This deals with the rights of the client as regards the use of data processing programs, specifically required to display/or print the documentation. Open quote: “With regard to data processing programs, the client has the right to use software on the specified hardware with the specified properties in unmodified format. The client may make two copies for data security.” Close quote.

If this is related to KNX, only the ETS software can be meant as a “data processing program”. The “specified properties in unmodified format” are nothing other than the ETS project itself or the types of documentation that can be derived from it. It is more precisely detailed in the VOB, Part C – DIN 18382 “General contracting conditions for building works, low and medium voltage installations with nominal voltages up to 36 kV”

(Reference: Issue December 2002).

Paragraph 3 “Implementation” contains the following:

Section 3.1.3 “The contractor must make all information available to the client necessary for the correct operation of the system.” And also: “This includes in particular:

-  Wiring diagrams
-  Address lists
-  Parts lists
-  .....
-  Functional descriptions

Interpretation: A wiring diagram in a bus system in the broadest sense is the topology, which can be created both in the form of a table as well as in graphical format. Address lists are nothing other than the individual addresses and group addresses of our KNX devices. A parts list is self-explanatory. Functional descriptions are the brief notes in the device comments and address comments as well as - if there is insufficient space - the installation notes for each individual device.

And finally:

Section 3.1.6 of DIN 18382: “The contractor must produce all necessary operating and maintenance instructions and necessary inventory plans as well as hand over this and individual project-specific data to the client”. It is thereby categorically stated that the

customer has a legally recoverable right that this data and plans are handed over, including those that are more or less “hidden” in a KNX ETS database. The contractor or the project designer of a KNX project should therefore be prepared to produce the underneath listed data and documents and issue them to the client in an appropriate and usable format.

#### 14.1.1 Contents of the project documentation

- ✚ Database: It seems at first the easiest way is to copy the ETS database of the project onto a CD or USB stick and then hand it over to the customer. This is possible in principle but only in the BACKUP format! The database that is being edited consists of several components as well as PC-dependent data, so it would be completely pointless to copy this data.
- ✚ The customer cannot however do anything with it without an appropriate ETS program. In other words, he must have an appropriate ETS license! Moreover, there may be a need for supplementary data, e.g. DLLs and help files or supplementary files of individual products, which may be indispensable if one wishes to change the products at a later date. Since ETS 3 and according to the manufacturers, all data from the “Baggage” directory can also be found in the relevant ETS database. For security, these “Baggage” files can also be copied. You can find these – if ETS has been installed in the standard directory “C:/Program Files/ETS” – in the subdirectory “C:/Program Files/Common files/EIBA sc/Baggage”, arranged according to the manufacturer codes.

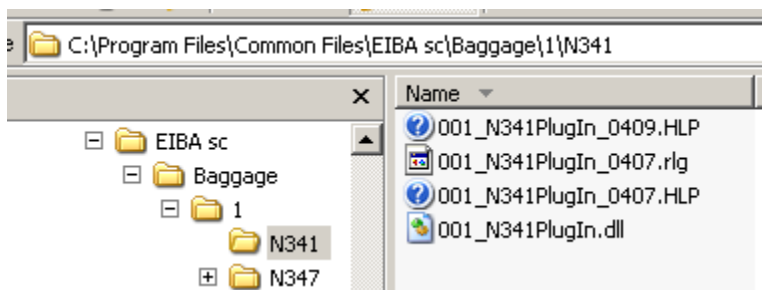
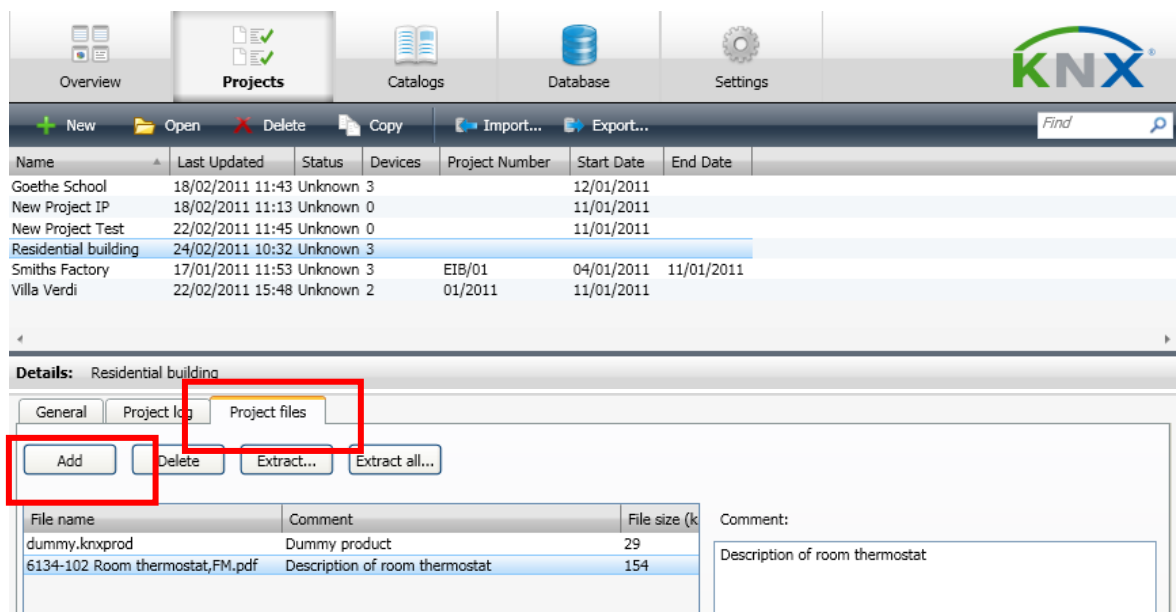

**Figure 64: Baggage (=supplementary) files**

- ✚ Project export: the project exported in full generally contains the supplementary files and dll's. It should however always be checked anyway, whether this is indeed the case (re-import in an empty database).
- ✚ Supplementary programs (SETUP): some KNX devices require additional setups (their own configuration programs). For completeness sake, such programs should also be put on the CD for the customer. These programs are normally supplied free of charge by the relevant manufacturers and can be copied without any restriction.
- ✚ Supplementary files (DLL, text etc.): see points 1 and 2!
- ✚ Parts lists
- ✚ Topology
- ✚ Building structure
- ✚ Group addresses

ETS offers an elegant way to archive all project data – including plans and data from other programs, tenders, functional specification etc. – in the project export file under

“Project files”. If you click on “Add”, an Explorer window opens, where you can search for files and insert them.



**Figure 65: Inserting additional files**

Note: All data that is handed over in electronic format requires specific program and operating system versions. This data is also part of the complete documentation. The contractor of course does not need to issue licensed programs such as ETS or Windows.

#### 14.1.2 Handover to the client

Finally, the documentation mentioned above must be handed over to the client in any case. The eib.db + supplementary files and export file are normally of equal value, i.e. you can limit yourself to one of them. What however is frequently discussed is how you can protect your rights as a contractor towards the client? 2 comments must be made: According to paragraph 3.1.7 of the German contracting procedure for building works/DIN 18382, the examination of the building as regards operational reliability (evidence of each individual function) and according to the relevant DIN norms (or relevant international standards, for KNX e.g. EN 50090) must take place with appropriate documentation of the test results. The minutes of this examination must normally be handed out to the client before his acceptance for a possible re-check.

A technically skilled client could now make changes in the project later on, if he has the complete ETS project data.

In order to protect yourself as a contractor, it is advisable to activate the project password and to hand it over to the client separately in a sealed envelope. If any problems should occur after the handover, which should be remedied within the warranty conditions by the contractor, he could check to see whether the envelope is damaged or not. If the seal should have been removed, the contractor would not be liable for any malfunctions.

### 14.1.3 Duties / behaviour of the contractor after handing over the project

The contractor must observe the legally stipulated warranty periods as common for the trade. What does that have to do with the “completeness of the documentation”?

Well, a contractor has to safeguard himself against unauthorised warranty claims by the client, once the installation has been completed. Many electronic data storage media are completely unsuitable for saving data over a longer period of time. Unfortunately this issue is often not considered sufficiently. The handling of critical data is often done too carelessly e.g. ETS projects are frequently created and saved in the same database. This database is also saved only now and then. If there is a computer crash, e.g. because of a hard drive defect, or a virus has deleted all the files, big problems arise. One may too easily assume that the client might still have the data, because it has already been handed over and could therefore be easily recovered.

But what happens, if the client has in the meantime also lost data? Or the client has initiated a lawsuit because there are differences of opinion regarding warranty issues etc.? Without your own evidence, you are in trouble if you are the accused.

Therefore – in his own interest – the contractor should save all data on special media for long life storage, and moreover store it in a safe place, e.g. in a locked vault at a bank. In large projects, where small mistakes can still cause a significant loss of money, it is recommended – even, if it costs money – to have the data legally certified, sealed and then deposited at a bank. In case of warranty issues, the validity of this data can then not be put into question.



# KNX Commissioning ETS4

KNX Association

## Table of Contents

1	General .....	3
2	Commissioning .....	3
2.1	Commissioning requirements .....	3
2.2	Local or imported projects .....	4
3	Starting the commissioning .....	6
3.1	Bus access .....	7
3.2	Configuring the interface .....	8
3.3	Configuring the local device.....	12
3.4	Opening a project .....	13
3.5	Selecting a view .....	14
3.6	Downloading .....	15
3.7	Assigning individual addresses.....	17
3.8	Loading the application (application software) .....	18
4	Reconfiguration.....	19
4.1	Implementing project design changes .....	19
4.2	Reprogramming filter tables.....	20
4.3	Commissioning devices .....	20
5	Unloading devices.....	21
6	Resetting devices.....	22
7	KNX Powerline commissioning.....	23
7.1	Checking the local domain address (System ID) .....	23
7.2	Checking the domain address (System ID).....	24
7.3	Loading the basic configuration (setting the repeater status) .....	24

## 1 General

All PL 110 information in this chapter is only for informative purposes. The PL 110 content is not part of the exam at the end of the basic course.



## 2 Commissioning

### 2.1 Commissioning requirements

The commissioning of a KNX installation does not necessarily require the complete set-up of the bus installation with all the bus devices. In larger projects (several building sections), it does make sense to pre-program e.g. bus couplers in one's office or in the workshop. Since it is not an absolute requirement during the commissioning stage for the complete data set to have been loaded into the bus coupler, it may be useful to already load only the individual addresses into the bus couplers and the remaining relevant data when the bus couplers have been installed in the installation. Regardless of whether the commissioning is carried out in the office, workshop or on the building site, the application modules of the flush-mounted devices should not yet be mounted, so that programming button and programming LED remain accessible. In distribution boards, covers should be removed so that also for these KNX devices, the programming button and LEDs remain accessible. In the case of built-in devices in suspended ceilings or luminaires, it is advisable to already assign them with their individual address in the workshop, since such devices are generally only accessible with a great deal of effort once they have been installed.

The stipulated checks must have been carried out successfully during and after the installation.

The commissioning can be carried out via

-  a serial interface (not with 64 bit operating systems)
-  a USB interface
-  or a network connection

of the commissioning PC. The required settings are explained in more detail under "Bus access" and "Configuring the interface".

If the serial interface of the PC is a 9-pole plug, the serial cable to the KNX data interface must link the contacts directly (Pin1 to Pin1, Pin2 to Pin2, ..., Pin9 to Pin9). Since ETS3, it is also possible to commission a KNX installation via USB. In both cases, the corresponding settings must be carried out (see also "Configuring the interface").

All functions in ETS can either be called from the menu bar or via the context menus (right mouse button). A large number of functions can also be started directly via icons in the toolbar. ETS thus behaves like the majority of programs running under the Windows™ operating system. All subsequent screenshots only show examples. The functions do not necessarily have to be called in exactly the same way as described here. During the first steps with ETS, it is worthwhile using the right mouse button as frequently as possible as in many cases it leads directly to the desired dialog.

## 2.2 Local or imported projects

The project of the KNX installation must be contained in the database for commissioning purposes. If the project has been configured on a different PC, there are two possibilities:

The first option is to import the exported project with ETS onto the commissioning PC. The necessary steps are described in the “Project design” chapter. It is however necessary to ensure that all additional installed programs e.g. for touch panels are also installed on the commissioning PC.

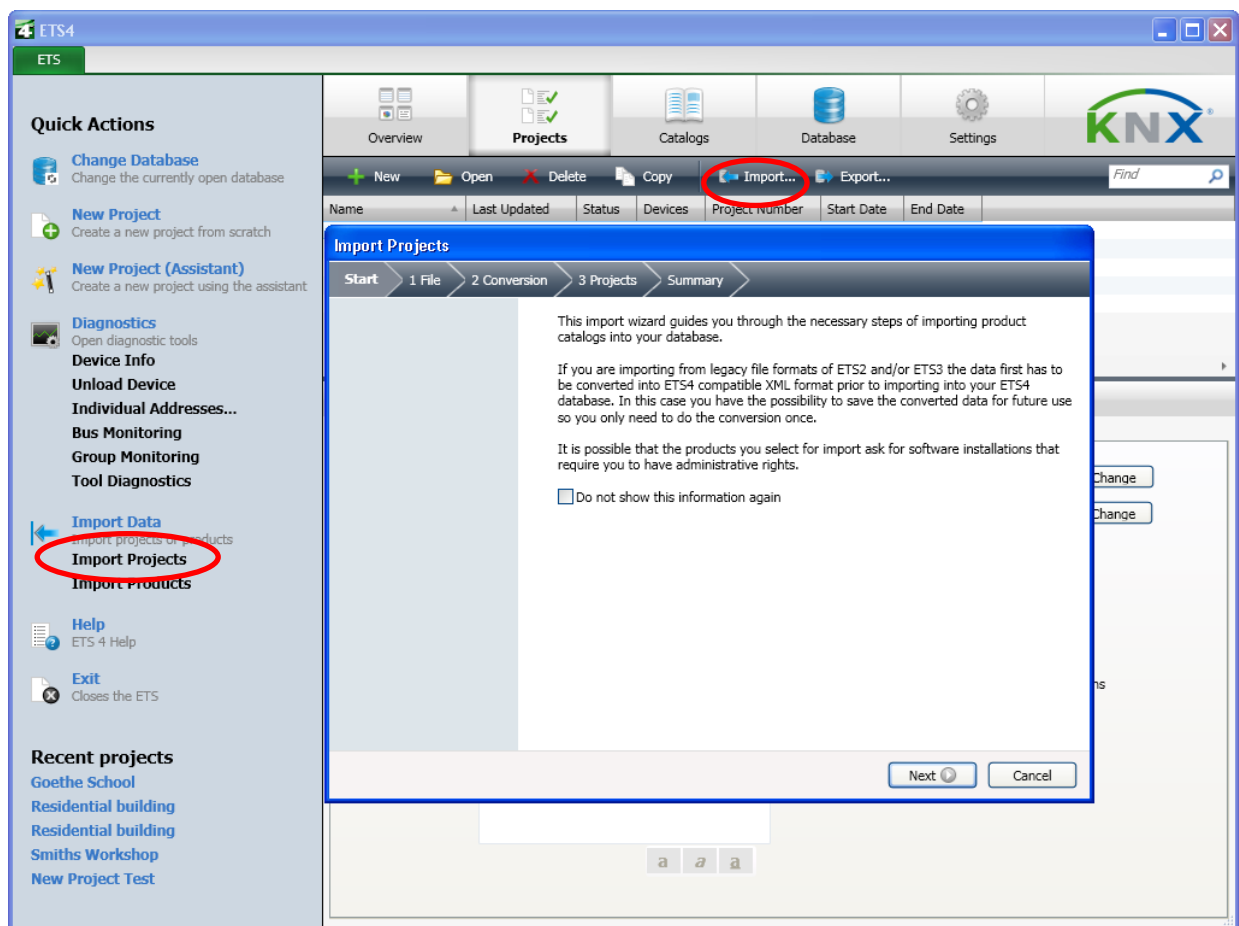

Figure 1: Local or imported projects

The second option is to copy the entire database. To do so, the database file must first be created in ETS (e.g. “knx.bak”) through the backup function. This file can thus be copied from the first PC to the second PC and recovered. This process has the benefit that all the products are contained in the database, should you wish to extend the project at a later date. The disadvantage is that the database can become under certain circumstances very large (several 100 MB). The database must either be burned onto a CD or copied with the help of a network connection or via another data carrier. One shall also pay attention whether the database contains products which can only run with additional files (DLLs, parameter files etc.). These additional files must be copied as well to the correct path. The recommendations of the manufacturers must be observed.

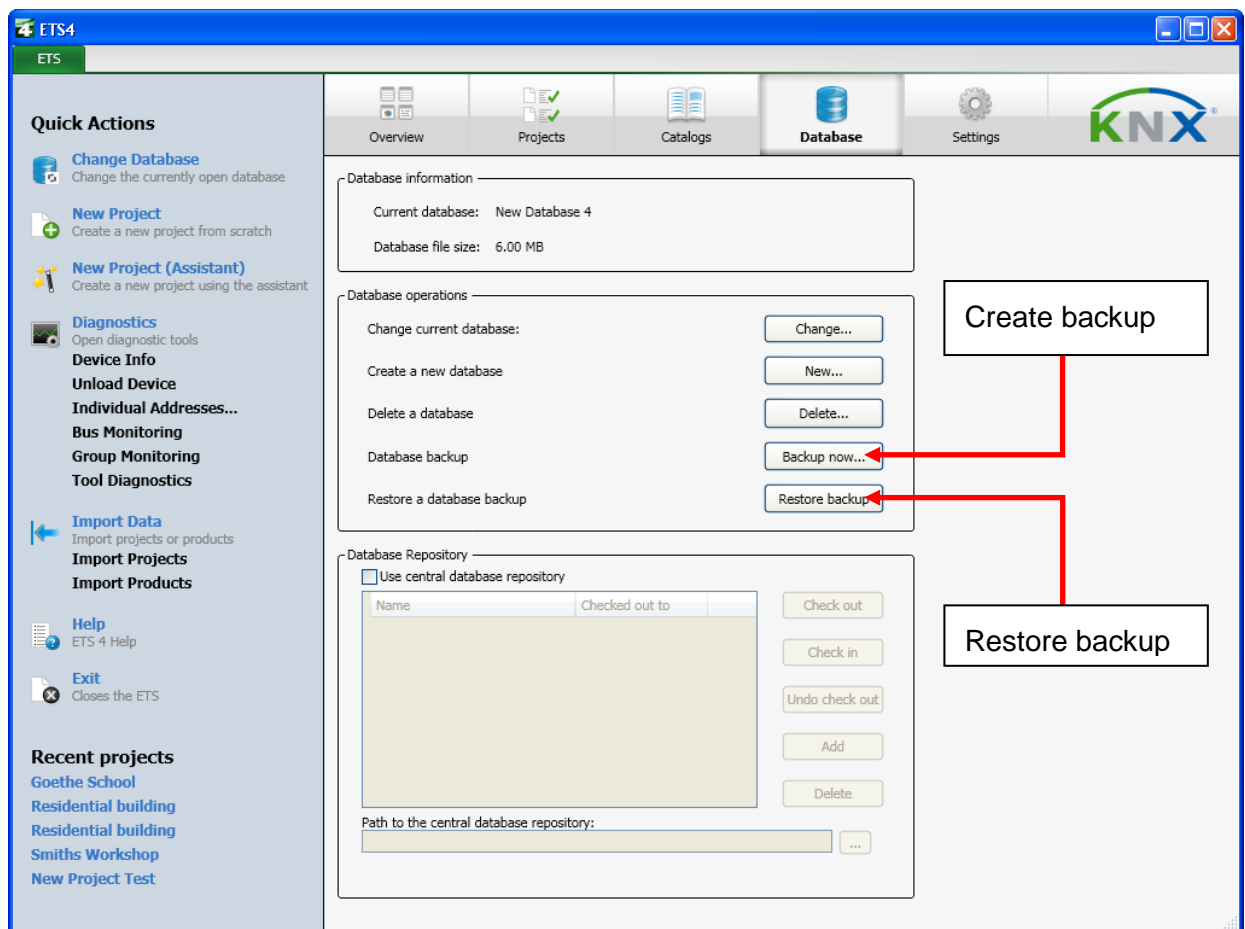









Figure 2: Copying a database

### 3 Starting the commissioning

You access the embedded commissioning dialog via the Buildings view, Topology view or Device view. In the corresponding window, the following menu icons appear for the commissioning or diagnostics purposes (alternative access: menu bar):

 <b>“Download”</b>	Opens the download menu for individual addresses and programs
 <b>Download individual address</b>	Downloads the individual address
 <b>Download application</b>	Downloads the application program
 <b>“Reset”</b>	Sends a restart command to a bus device
 <b>“Unload”</b>	Resets an already commissioned device to its original state
 <b>“Info”</b>	Reads out the information of a device
 <b>“Individual address diagnostic”</b>	Checks existing bus devices in the installation against the project design

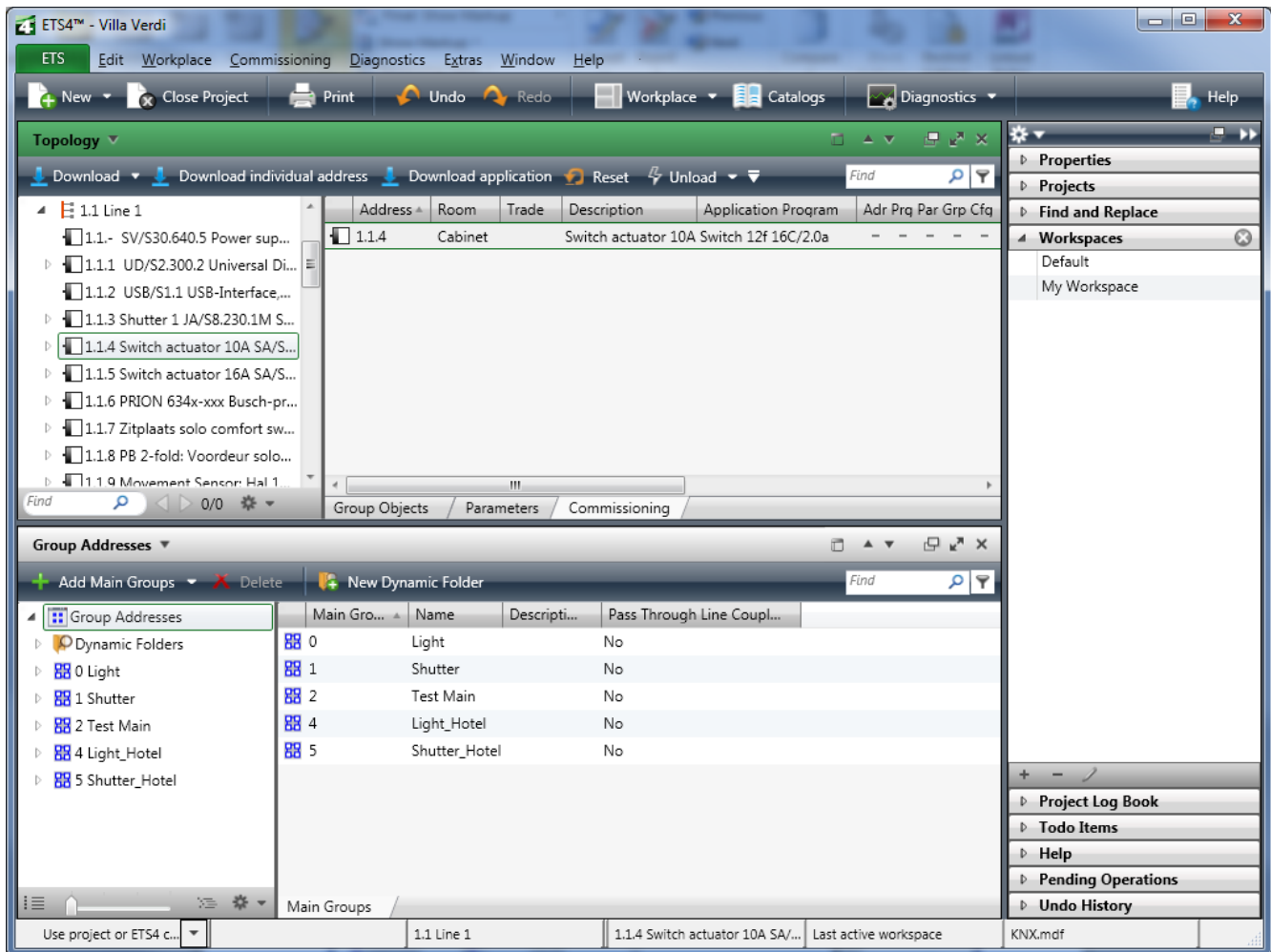

Figure 3: Starting the commissioning

### 3.1 Bus access

Before it is possible to start the commissioning process, it is necessary to firstly link the interface for bus communication with an appropriate cable connection to the commissioning PC and then to correctly select the settings on the commissioning PC. This can either be a serial interface (RS232), a USB interface or an IP network connection. The communication settings in ETS should be checked at any rate prior to the initial commissioning, regardless of the interface used. The “Communication” submenu is located under the “Settings” dashboard tab. The corresponding setting options can be found here.

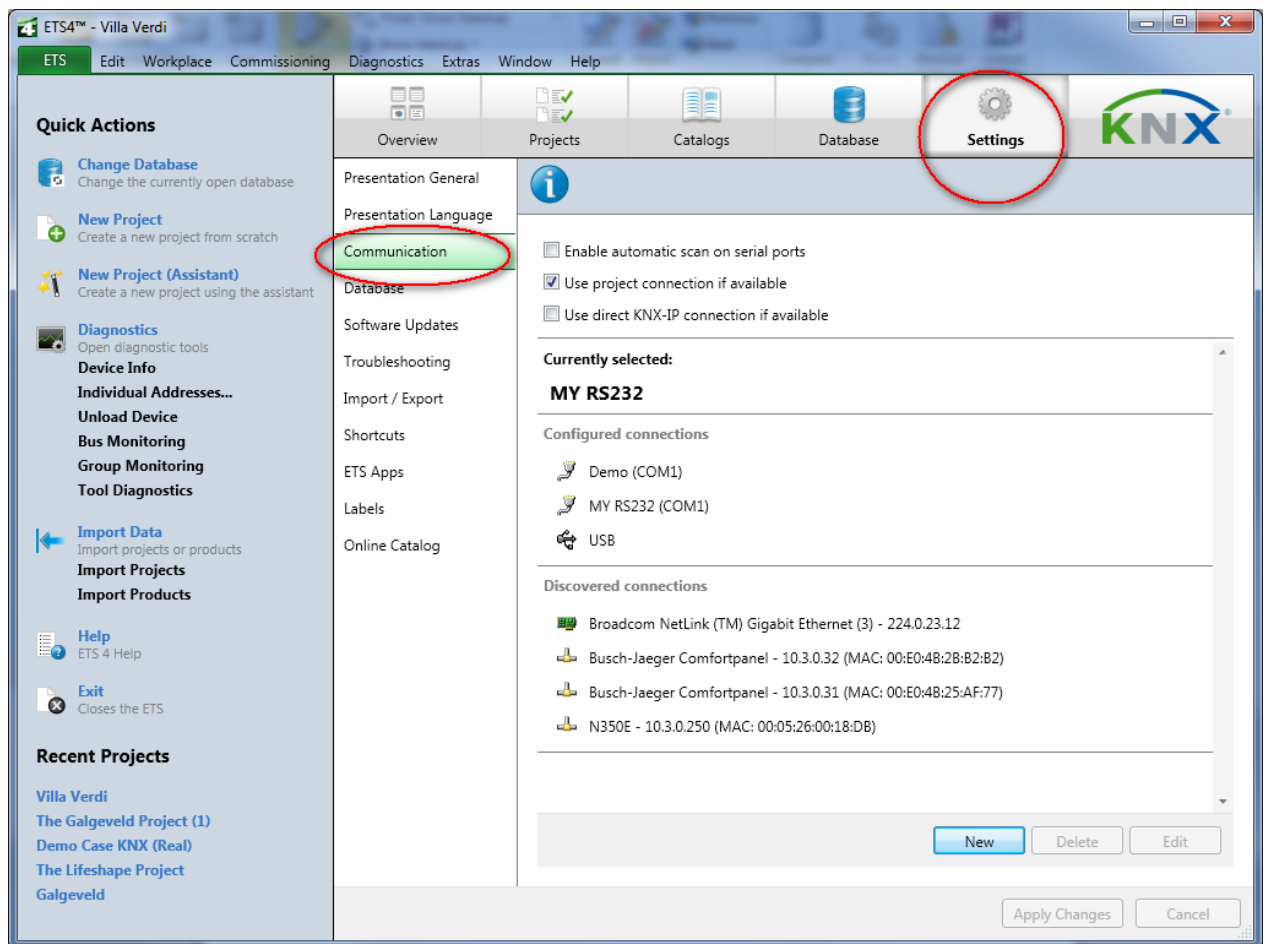

Figure 4: Bus access

### 3.2 Configuring the interface

If the “New” button is pressed in the “Communication” view, the dialog window “New connection” opens. It is possible to choose between the following connection options:

- |  |                   |                               |
|--|-------------------|-------------------------------|
|  | USB               | Communication via USB         |
|  | RS.232 Standard   | Serial standard connection    |
|  | RS.232 FT1.2      | Serial BCU2 connection        |
|  | IP (EIBlib/IP)    | Communication via iETS        |
|  | KNXnet/IP         | IP communication (tunnelling) |
|  | KNXnet/IP Routing | IP communication (routing)    |

If communication should be ensured via an RS232 connection, the COM-PORT on which the connecting cable from the commissioning PC to the RS232 is located must be selected under the communication parameters (normally COM 1).

When using a USB interface, the required KNX USB driver is installed directly the first time a connection is made to the PC.

**Note:** This occurs for each USB port i.e. if the USB cable is inserted in another USB port of the PC, the driver is installed again. Possibly, the connection pop-up menu must be opened once more, to ensure that communication functions again.



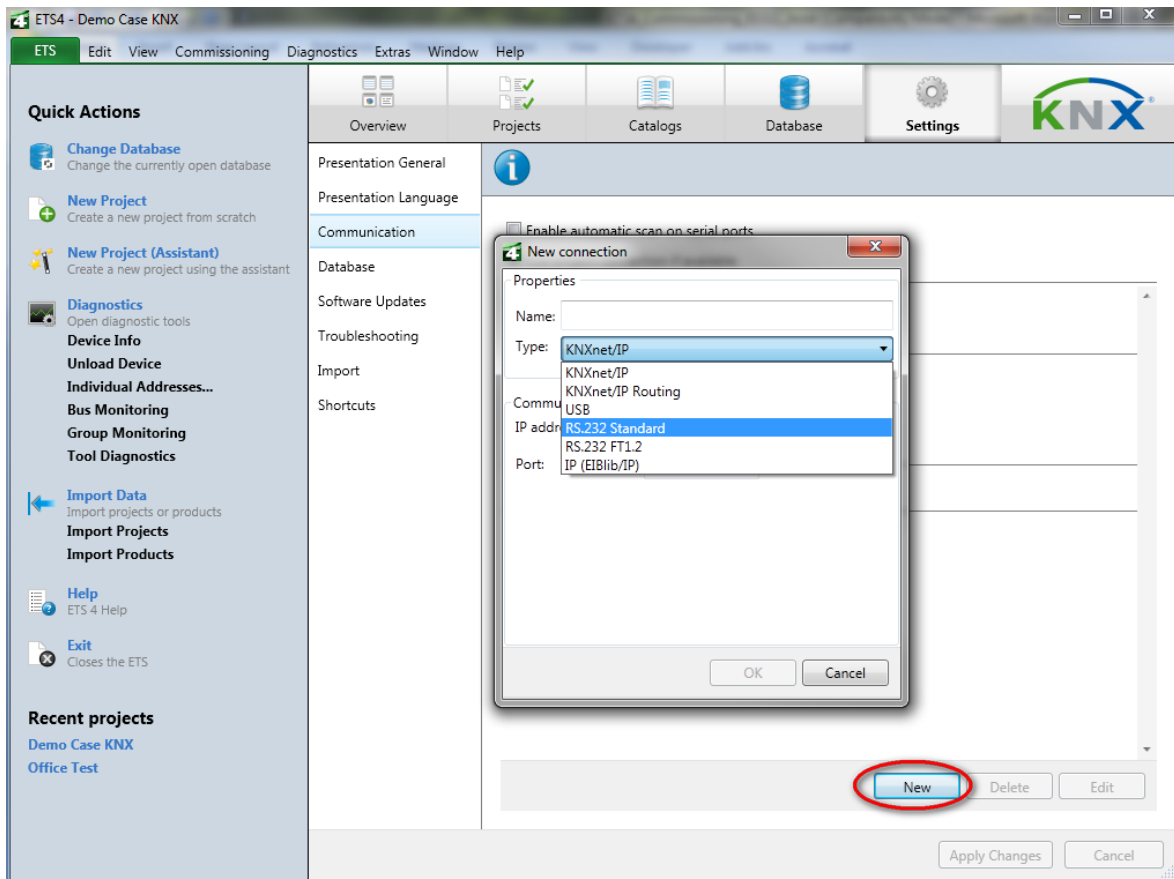

**Figure 5: Configuring the interface**

The communication type IP (EIBlib/IP) requires a device with a built-in iETS client. This is a software available in some IP gateways. For this type of communication, it is essential to know the IP address of the IP gateway.

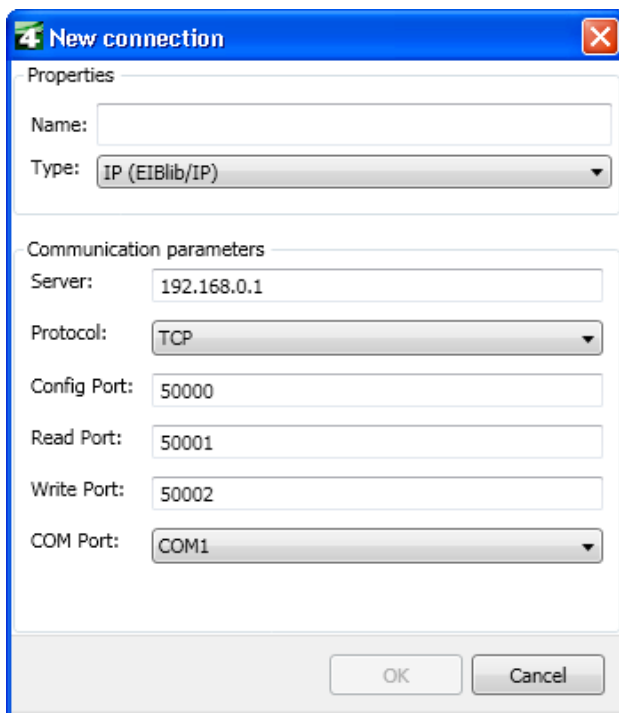

**Figure 6: IP (EIBlib/IP)**

IP couplers (IP routers) can be addressed using the KNXnet/IP protocol, also referred to as “tunnelling”. KNX telegrams are wrapped into TCP/IP and sent by ETS to the required IP coupler, which again removes the TCP/IP envelope and routes the KNX telegram to a subordinate lower TP area or TP line.

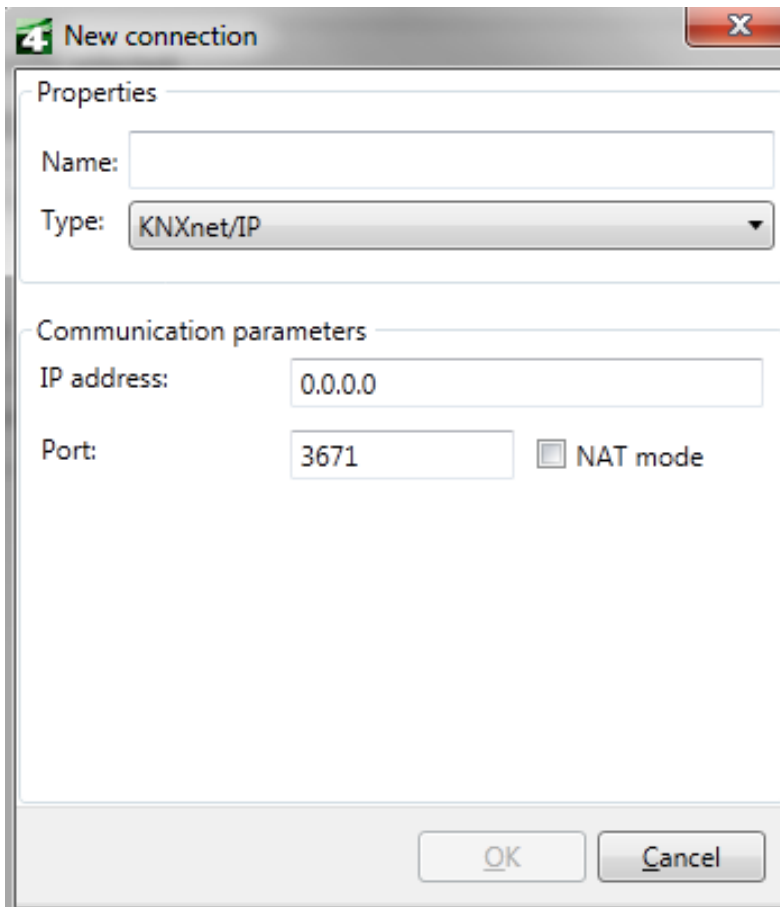

**Figure 7: KNXnet/IP Tunnelling**

With the communication type “KNXnet/IP Routing”, pure KNX IP devices can be addressed. These are devices that only have an IP connection. The communication type can also be used to carry out a diagnosis of the IP network connection (e.g. bus monitor).

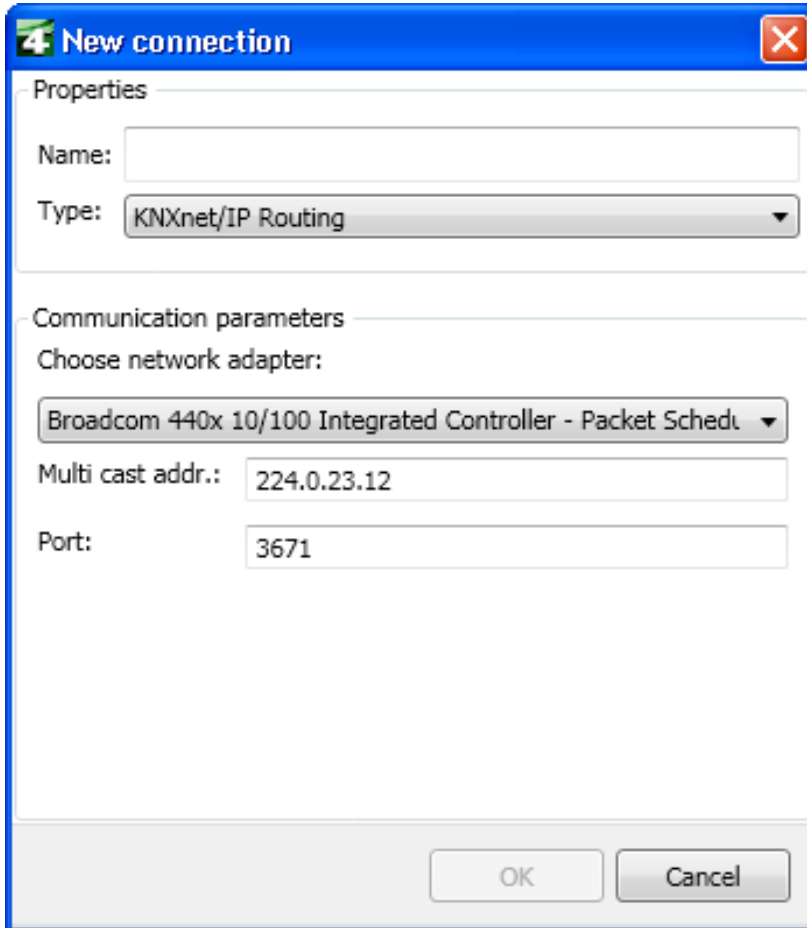

**4 New connection**

Properties

Name:

Type: **KNXnet/IP Routing**

Communication parameters

Choose network adapter:

**Broadcom 440x 10/100 Integrated Controller - Packet Sched**

Multi cast addr.:

Port:

OK Cancel

Figure 8: KNXnet/IP Routing

### 3.3 Configuring the local device

If one of the created connections is marked in the “Communication” view, the “Local settings” button appears which opens the “Local Interface Settings” dialog window. The individual address of the interface is entered here. The address must be set in such a way, that the area and line number match the current installation location of the interface. The device number must be an address not in use in the project. “255” is the most suitable device number as this high number is probably not present in the installation.

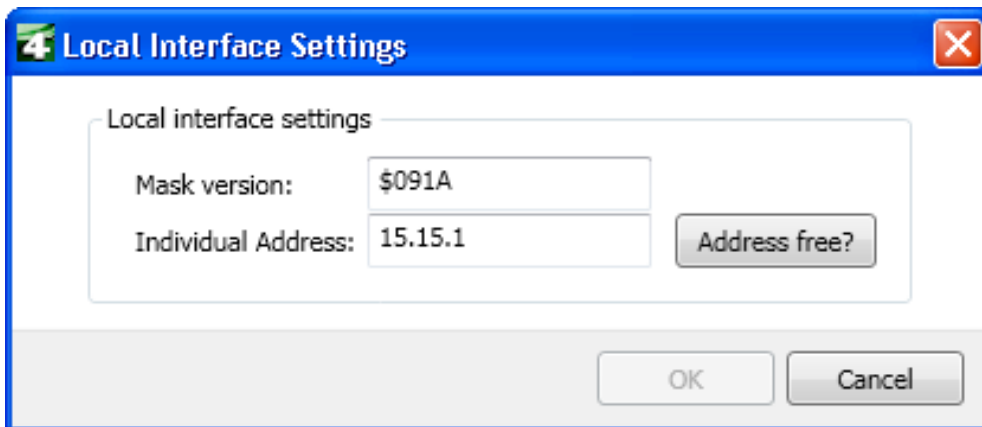

Figure 9: Settings of the local interface

If a flush-mounted interface is used for programming, which is removed from the installation after commissioning and replaced e.g. by a switch sensor, one shall immediately set the individual address of the device that will later be part of the installation.

If the local device is a Powerline mains coupler, a System ID must also be loaded. A corresponding value can be defined in the “System ID” field (see also chapter ‘Powerline’).

**Note:** Also when using an IP coupler as an IP interface, which will function as a line or backbone coupler during later operation, the local interface must be set. In this case, the IP coupler must adopt an individual address during commissioning, which matches its installation location in terms of the area and line (e.g. 1.1.255) and an individual address during normal operation which suits its function as a coupler (e.g. 1.1.0).

### 3.4 Opening a project

Once the commissioning requirements have been carried out, you access the projects via the “Projects” button on the dashboard. The “Open” button opens the project to be commissioned.

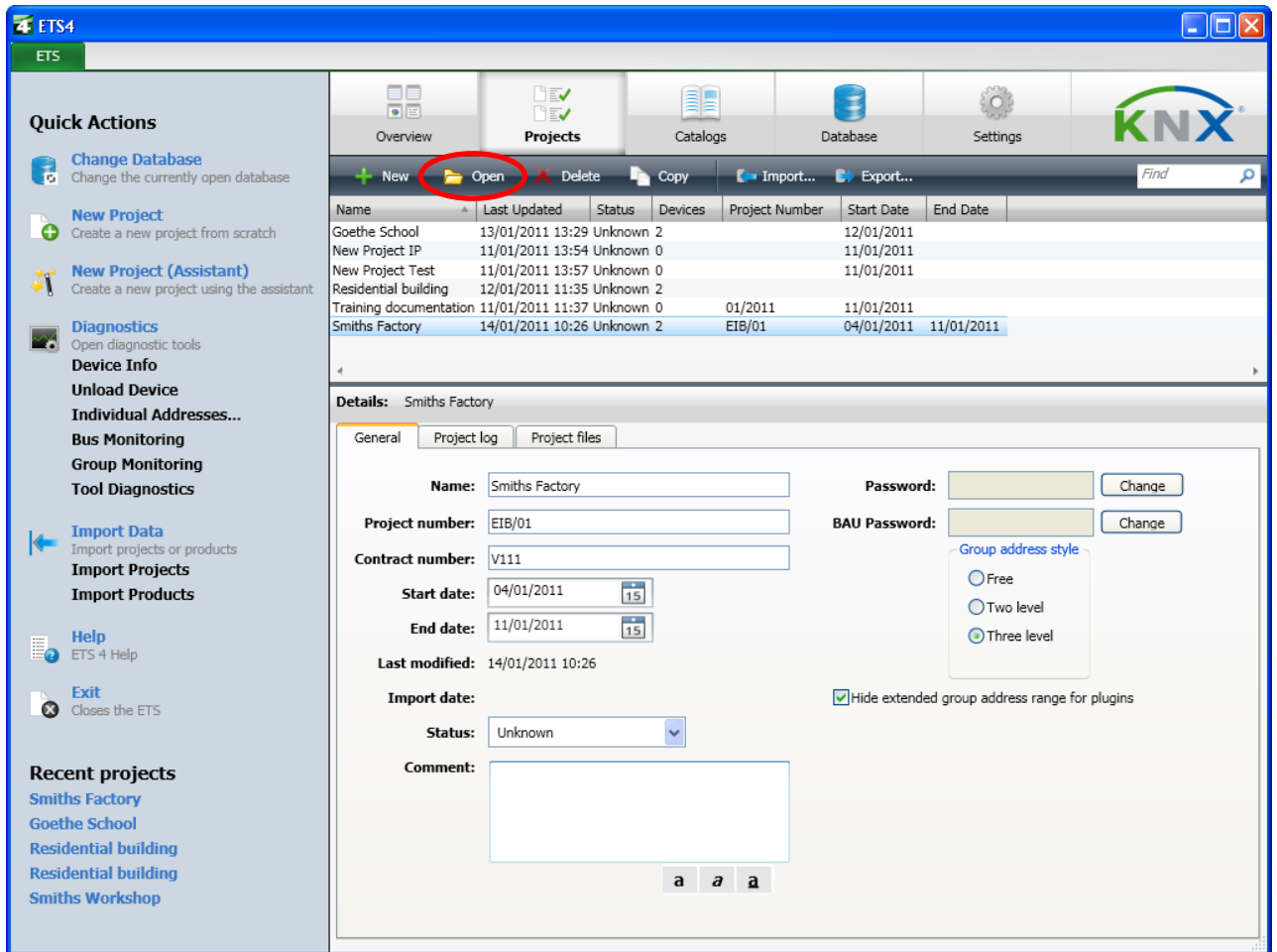

Figure 10: Opening a project

If one sets the interface options, it is of course not needed to close any opened projects. It is however advisable to only keep one project open during commissioning, as it can otherwise quickly lead to confusion.

### 3.5 Selecting a view

All views types can in principle be used during the commissioning phase. Each has its particular benefits. The Building view has the benefit that even if the individual addresses of the devices are not consecutive, it is not necessary to walk great distances on the building site. The Topology view has the advantage that several rooms can be commissioned in one go. In the Topology view, it is also possible to select a line and program it entirely in one go.

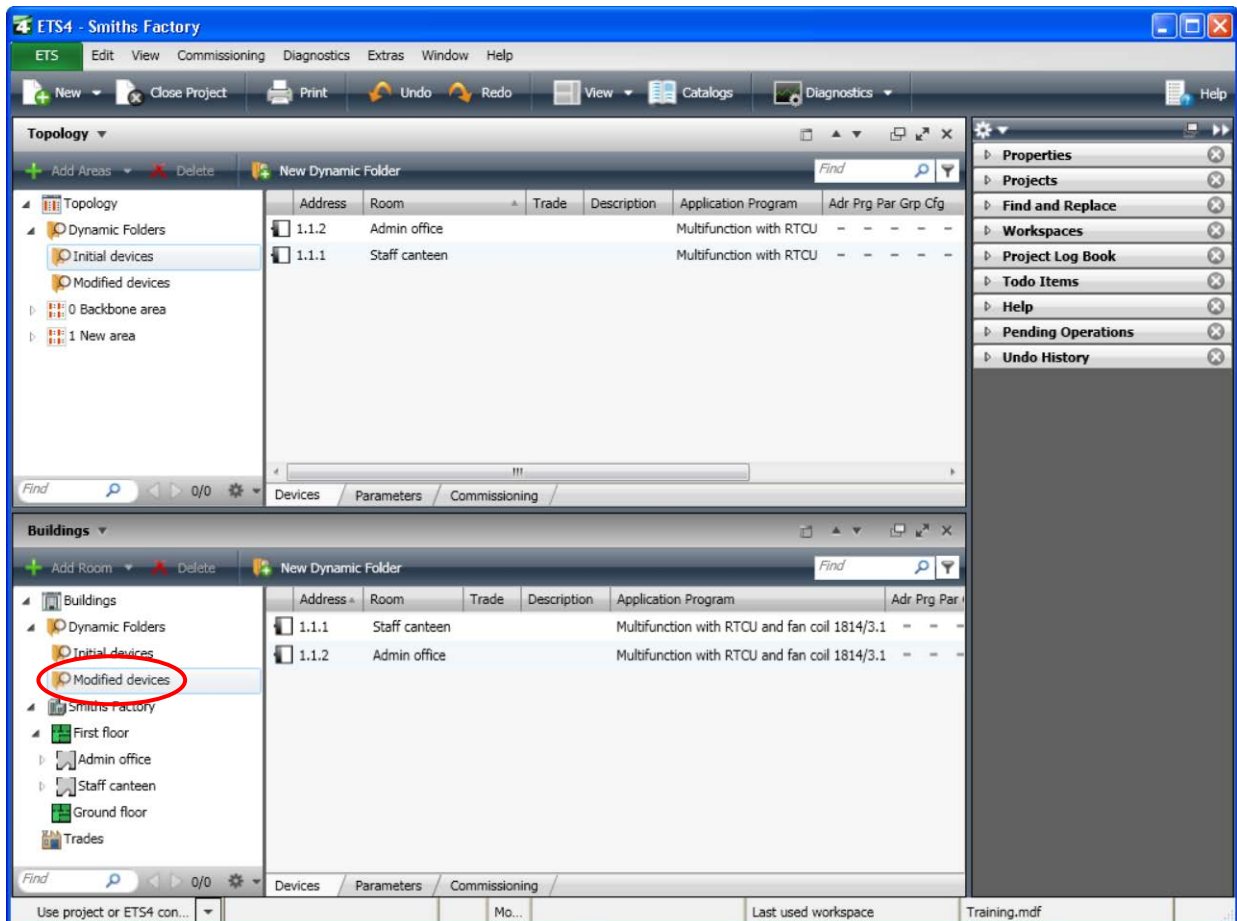







Figure 11: Modified devices

With the exception of the Group Addresses view, one has access in every view to the “Modified devices” via the “Dynamic Folders”. Here only those KNX devices are shown, of which the properties have been modified by the user since their last download.

### 3.6 Downloading

You can access the embedded commissioning dialog via the “Download” button, whereby the following functions are available (alternative access: menu bar → Download):

 <b>“Download All”</b>	Download of the individual address and the application program (press the programming button)
 <b>“Download Partial”</b>	The missing data is downloaded (Programmed flag not set)
 <b>“Download Individual address”</b>	Download of the individual address (activation of the programming button)
 <b>“Overwrite Individual address”</b>	Enabling on selection of a device whose individual address should be overwritten (no activation of the programming button)
 <b>“Download Application”</b>	Download of the application program

In order to download the individual addresses to the devices, it is necessary to click on “Download Individual address”. After starting the download process, the “Pending Operations” view opens in the side bar. You are now requested by ETS to press the corresponding programming buttons of the devices. The progress of the download process is then displayed in this view.

**Note:** If a coupler is present, it should always be at the top of the list and thus also be programmed as the first device with the individual address.

Then click on “Download Application” and the program, group addresses and the parameters (including in case of line/backbone couplers, the filter table) are loaded into the devices.

Alternatively, the downloading of the individual address and application program can be processed in one step via the option “Download All”.

A partial download can be selected via the “Download Partial” menu. This download option can be applied if only modified data such as group addresses or parameters should be downloaded.

It is possible to continue working in ETS during the entire download process. Only those devices currently being downloaded are blocked for editing.

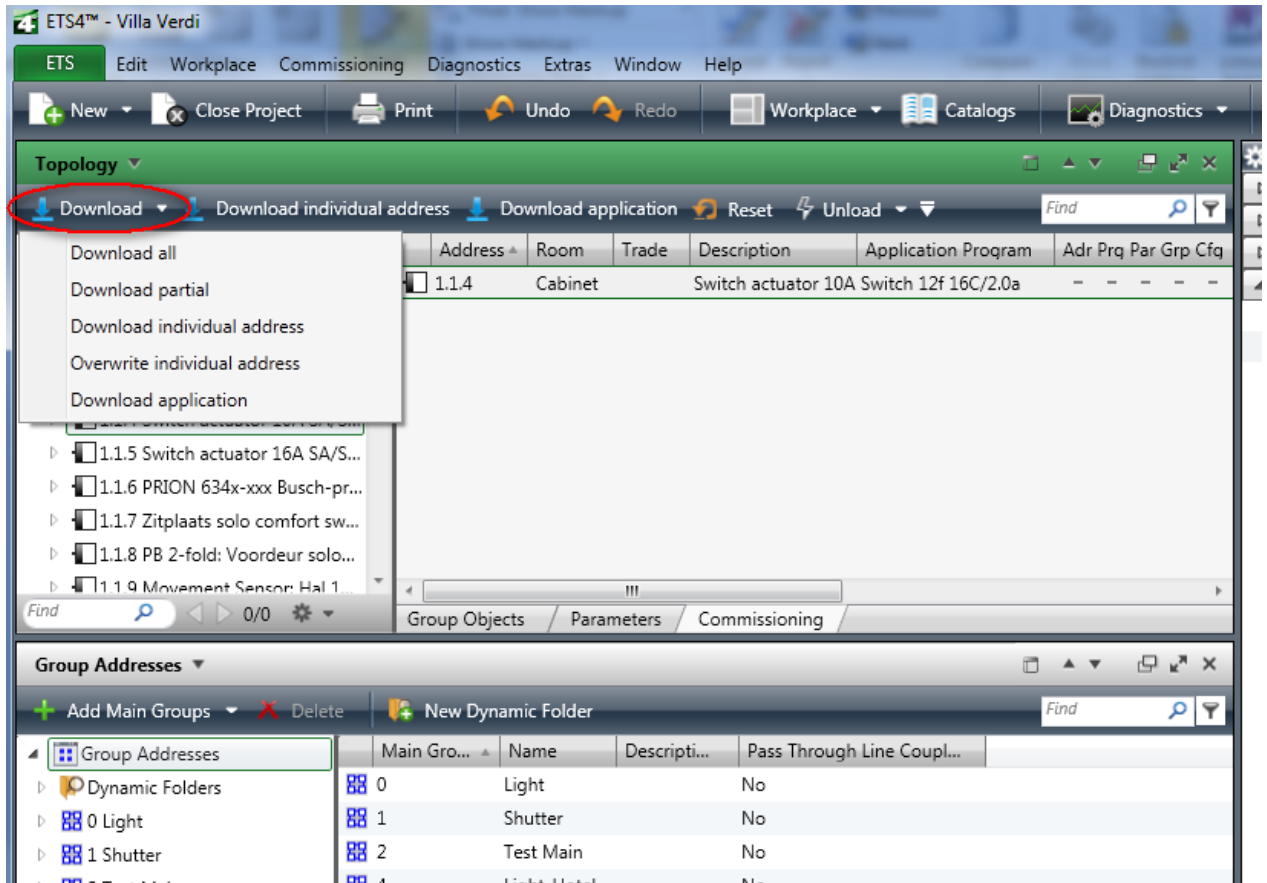

Figure 12: Download

**Note:** If a flush-mounted interface is used for commissioning which is mounted onto a bus coupler that will later serve as a switch sensor, it must first be downloaded locally. The ETS program automatically detects that it is this type of device and queries in a dialog whether the programming of the local device should be carried out.



### 3.7 Assigning individual addresses

During the commissioning of a KNX installation, it is important that after the interface any couplers available in the KNX project are assigned a correct individual address, before any other device is programmed. The right strategy is to address the coupler in a star pattern; then to download first the coupler(s) of the local line and then all subsequent couplers. Otherwise, communication errors may occur.

Alternatively, it is possible to first disconnect all couplers and individually program the lines. The couplers are then re-connected and programmed one after the other. After selecting the “Download individual address” option, ETS checks whether the device already exists on the bus and then asks you to press the programming button.

As the application program also contains the filter table in the case of a line coupler, it is essential in case of couplers to load also the application program.

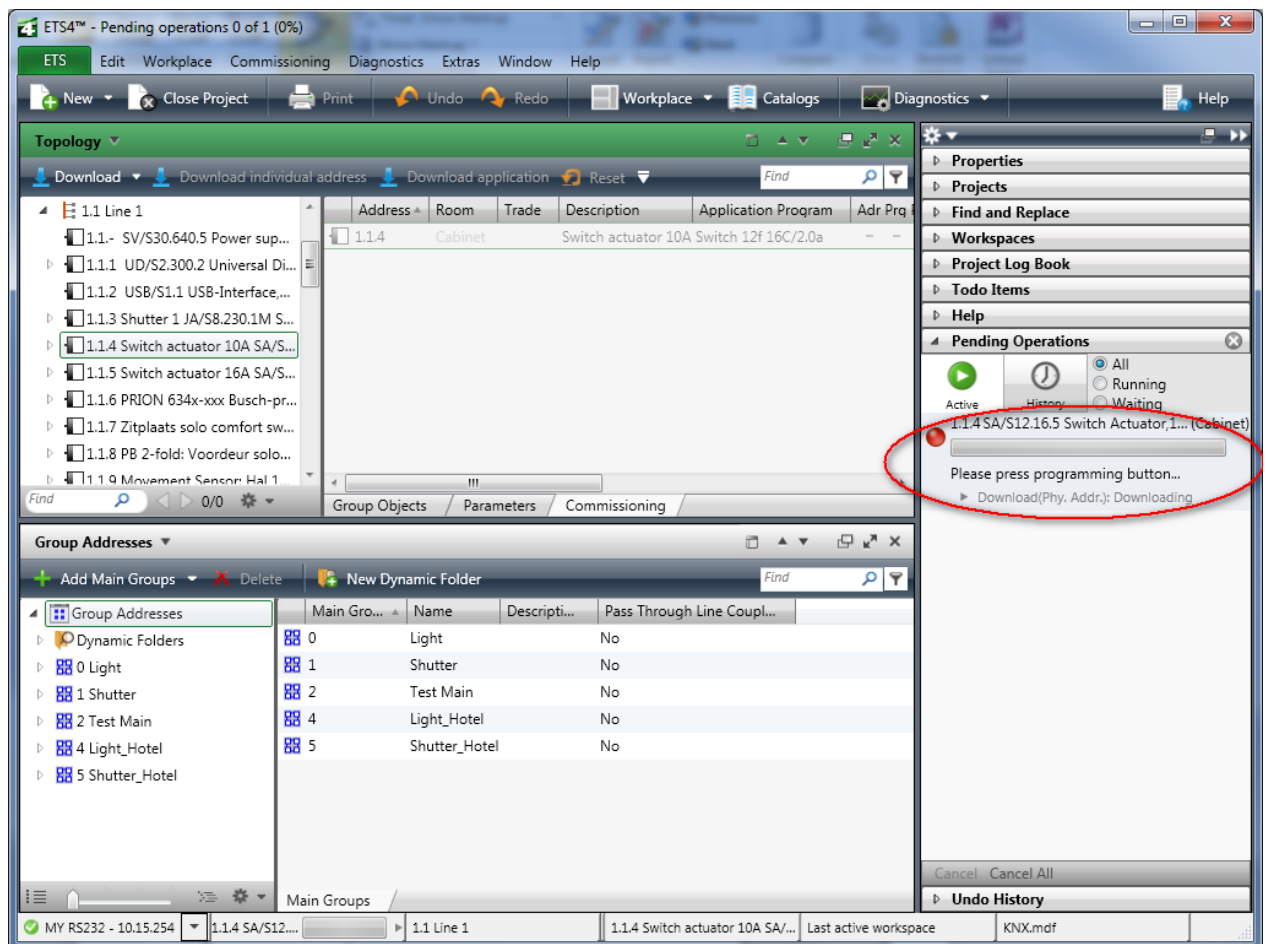

Figure 13: Assigning individual addresses





### 3.8 Loading the application (application software)

A KNX device is only fully functional once the application has been loaded into the KNX device in addition to the unique address (individual address). If the individual address has been loaded, this is shown by the “Adr” entry in the column “Adr Prg Par Grp Cfg” when selecting the Commissioning Tab.

To load the application, the corresponding KNX devices must be marked in the Buildings, Topology or Devices view via the embedded commissioning dialog. The “Download” button then appears in the bar. The download process is started by clicking on “Download Application”. The current progress of the download can be tracked using the text and status bar (Figure 14).

If after loading, one establishes that changes to the application are still necessary, it may be in many cases sufficient to load the modified applications only partially (“Download Partial” button).

Once the application has been loaded, ETS indicates the download status with the corresponding entries in the column “Adr Prg Par Grp Cfg”:

-  **“Adr”** Individual address is downloaded
-  **“Prg”** Application program has been loaded
-  **“Par”** Parameter settings have been loaded
-  **“Grp”** Group addresses have been loaded
-  **“Cfg”** Media type specific settings have been loaded (set when downloading the individual address)

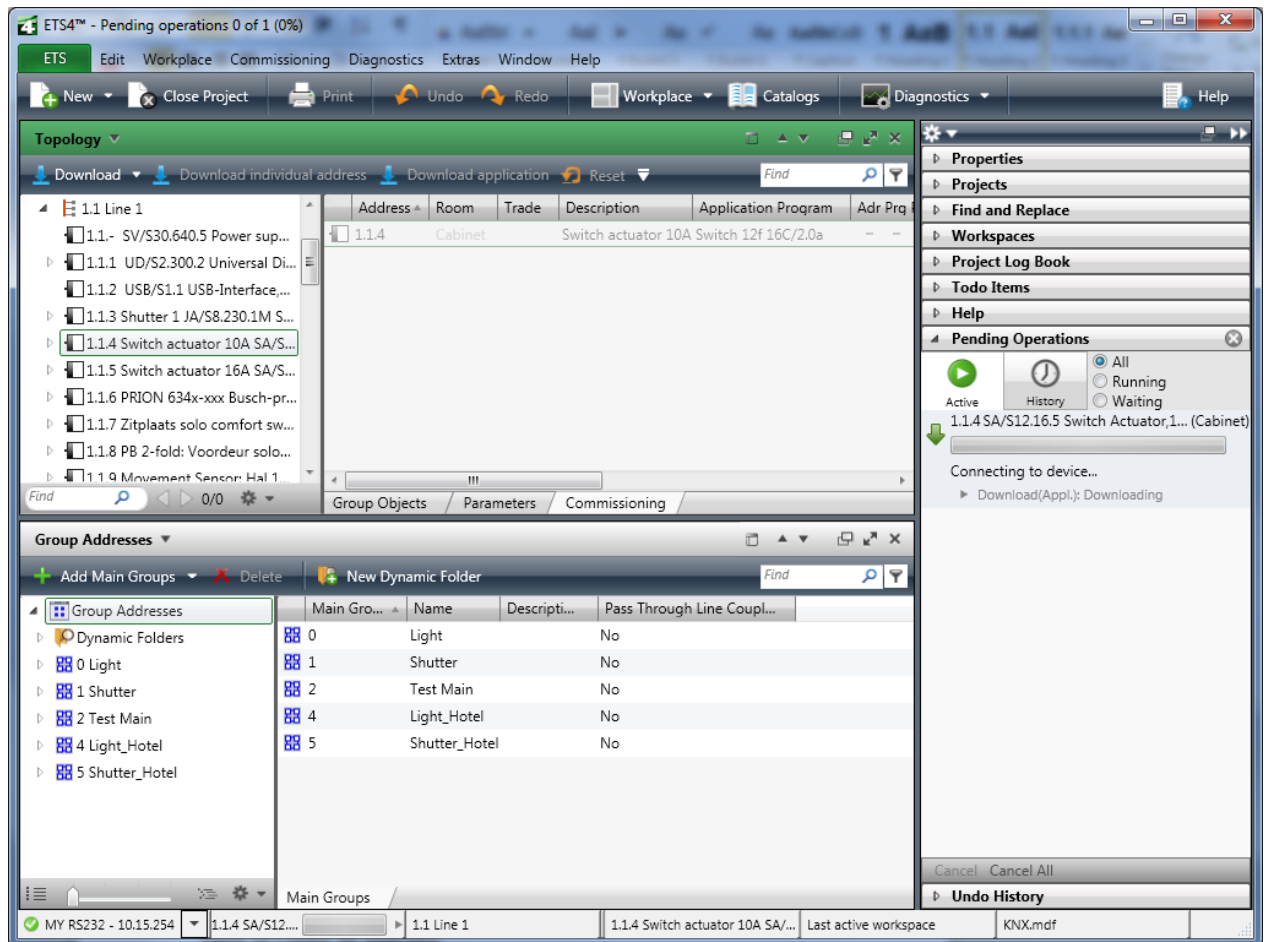





Figure 14: Loading the application

## 4 Reconfiguration

If you need to modify a KNX installation, processes are similar to those during project design. When working on a PC, it may however turn out that certain products that are necessary for carrying out the modifications are not contained in the database. This is particularly the case when two different PCs are used for the project design and commissioning e.g. when a desktop PC is used in the office during the project design and a laptop is used on the building site during commissioning. In this case, the missing devices must be imported at a later date.

### 4.1 Implementing project design changes

With ETS, it is possible to implement project design changes during the commissioning phase. Please proceed precisely as already described in the “Project design” chapter. Changes to all relevant settings can be carried out:

-  Application program
-  Parameters
-  Group addresses
-  Flags

## 4.2 Reprogramming filter tables

If changes still need to be carried out to individual devices during commissioning affecting several lines, it is necessary to reprogram the filter table. This is ensured by partially reloading the group addresses in the affected line couplers. Of course, alternatively, the complete application can be loaded into the couplers. Only if additional group addresses have been linked to a line, does ETS display the entry “Manual filter table entries”. If manual changes have been carried out here, the corresponding couplers must likewise be reprogrammed (partial: group addresses). Group addresses are manually added to the filter table, by dragging them onto a physical line via drag & drop (Figure 14.1).

**Note:** ETS automatically updates the project filter tables in the background.

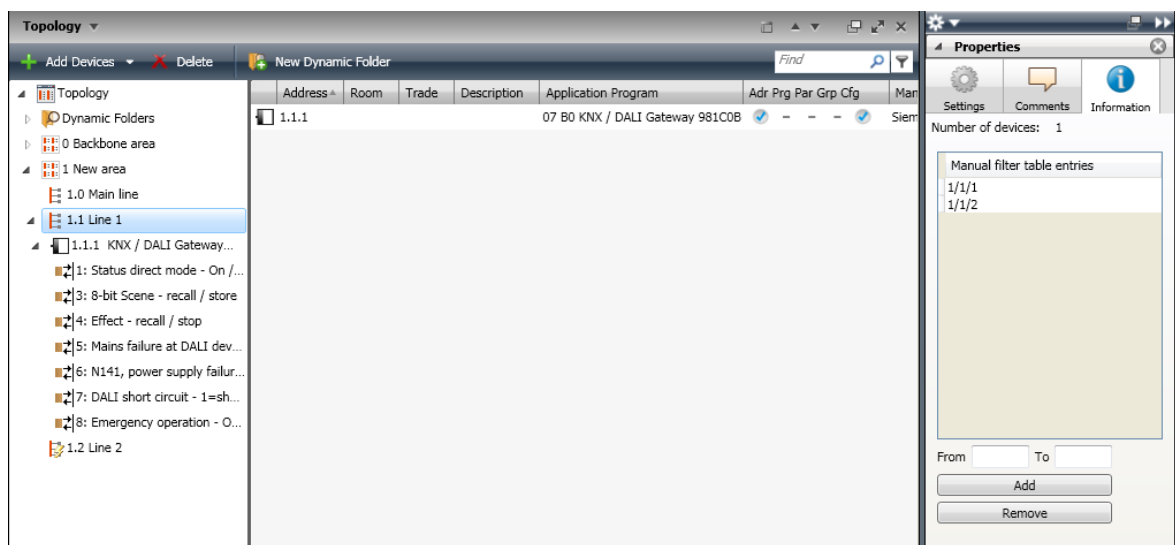

**Figure 15: Manual filter table entries**

## 4.3 Commissioning devices

Once the project design changes have been carried out, the affected devices must be recommissioned. To do so, please proceed as described in the first part of this chapter. Please bear in mind that it is also possible to download the devices partially. This can save a great deal of time e.g. if only time related parameters need to be modified for 20 dimming actuators, it is a good idea to download just the parameters rather than the entire application.

## 5 Unloading devices

If a device has been loaded by mistake, it is possible to unload it completely in the commissioning menu via the “Unload” submenu, whereby there are two possibilities for this function. The first option is to select “Unload application”: this will leave the individual address untouched in the device. This process will not delete the entire program but simply set all possible error flags. The other option includes the additional unloading of the individual address. To do so, select “Unload address and application” from the menu (Fig.16/1.). For security purposes, ETS will prompt you before each unload process, whether the device should really be unloaded. In addition, the programming button must also be pressed (Fig.16/2.).

If a device has been fully unloaded, the individual address is reset to the original state. An unloaded device has the individual address 15.15.255.

The progress of the unloading process can be monitored in the side bar under “Pending Operations” (Fig.16/3.).

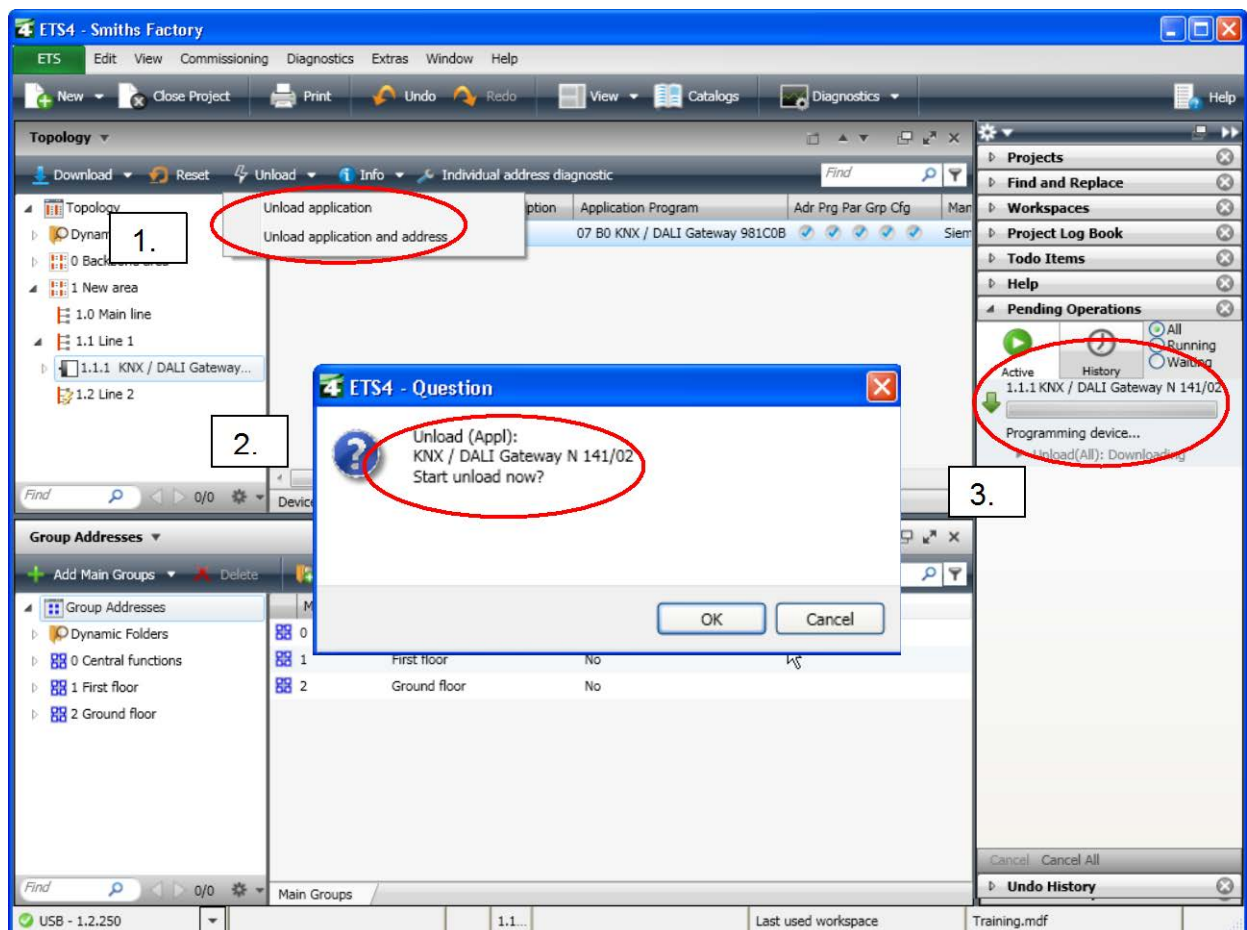

Figure 16: Unloading devices

**Note:** It is not possible to unload couplers (the individual address is set to 15.15.0).

## 6 Resetting devices

The command “Reset device” can be called as context-sensitive (right mouse click on the corresponding device), via the embedded commissioning dialog or via the commissioning menu. This process is also shown in the side bar under “Pending Operations”.

The reset of a device will restart the bus coupler (operating system and application program).

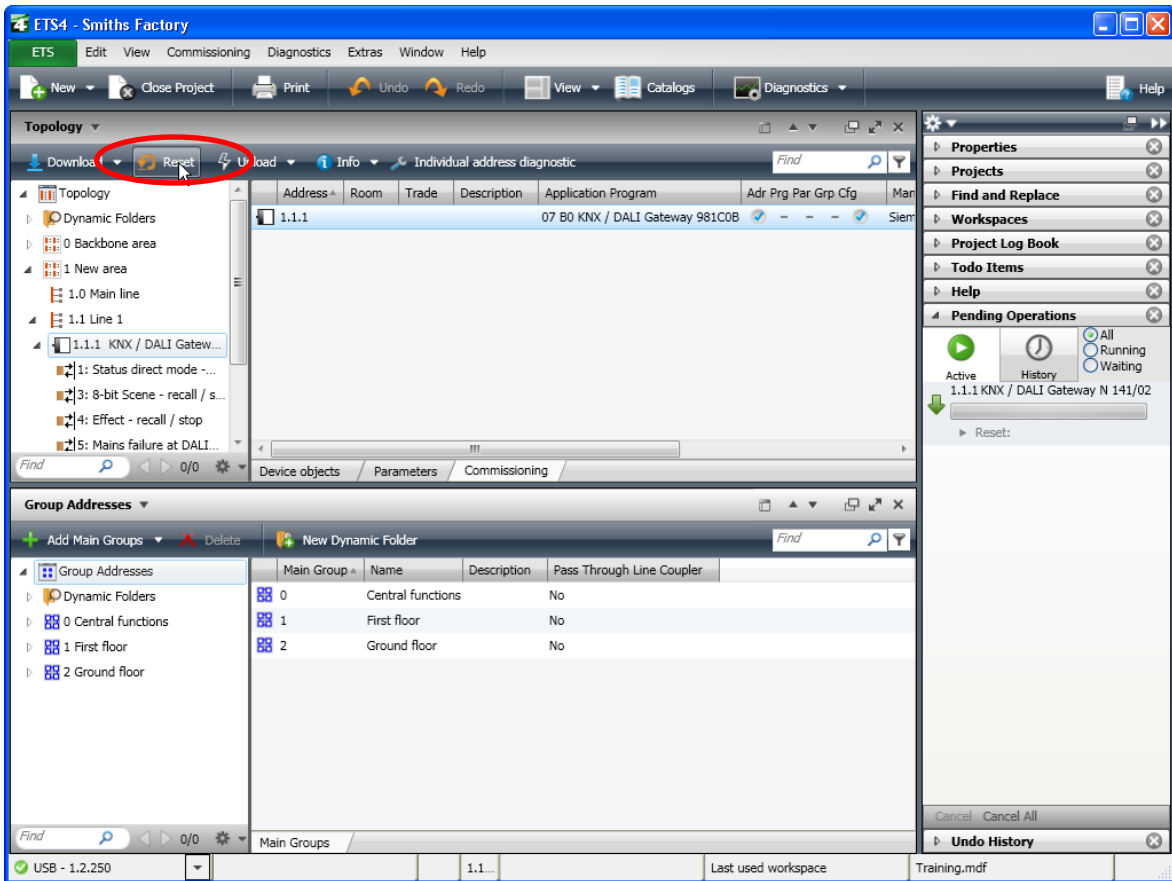

Figure 17: Resetting devices

## 7 KNX Powerline commissioning

### 7.1 Checking the local domain address (System ID)

Before a Powerline installation can be commissioned, the local interface should always be checked for its domain address (System ID). The local interface must always have the same domain address as assigned in the topology during the project design phase. The domain address of the interface can be found under “Local interface settings”.

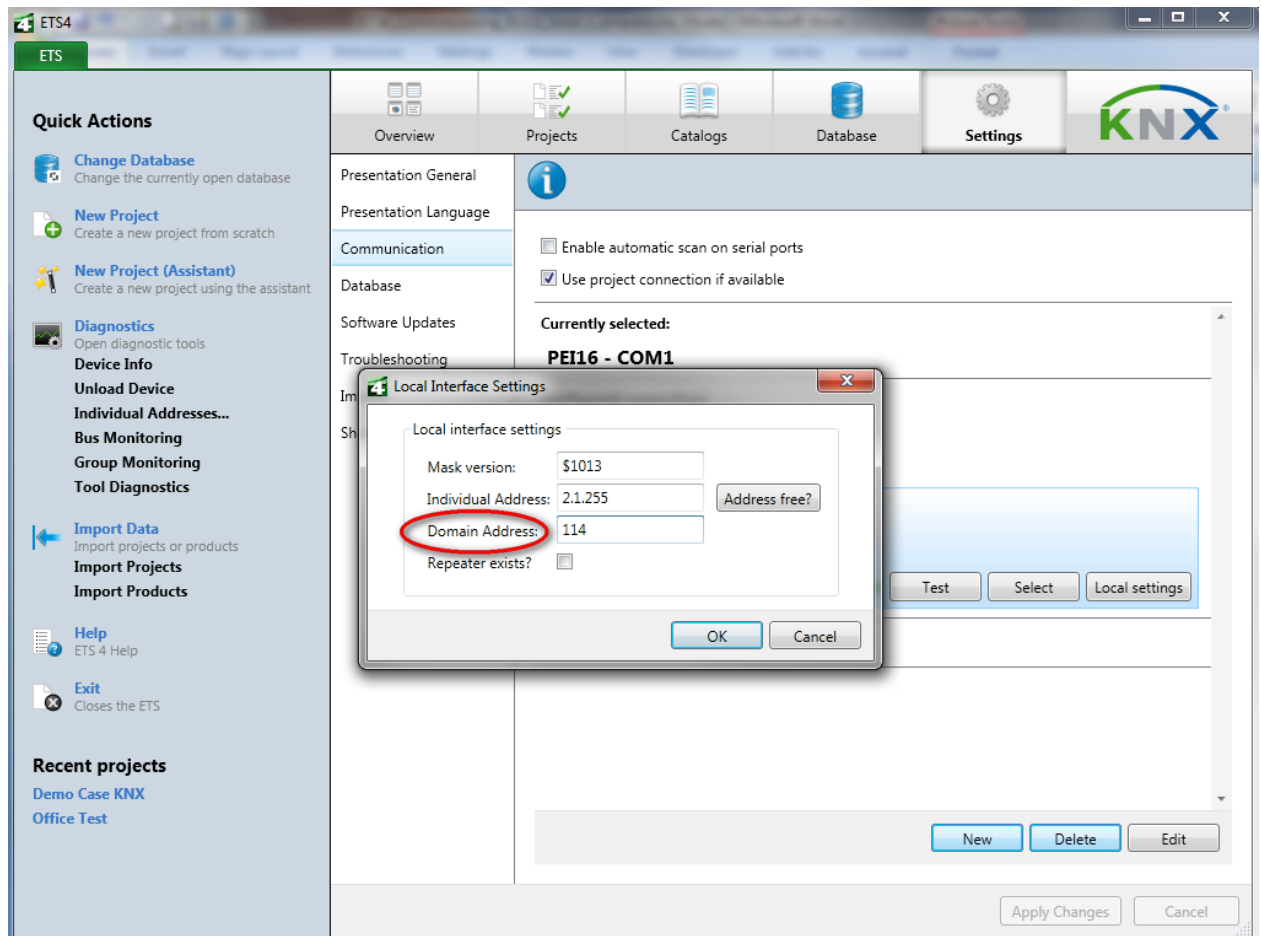

Figure 18: Checking the local domain address (System ID)

## 7.2 Checking the domain address (System ID)

Before commissioning a Powerline KNX installation, it must be checked whether the domain address is unique. The same domain address may not be present in the vicinity of the installation. Powerline devices can only be programmed after checking the uniqueness. The corresponding line in the bus topology must be selected to check this. The domain address is displayed in the side bar under properties. A new domain address can be created here or changed manually.

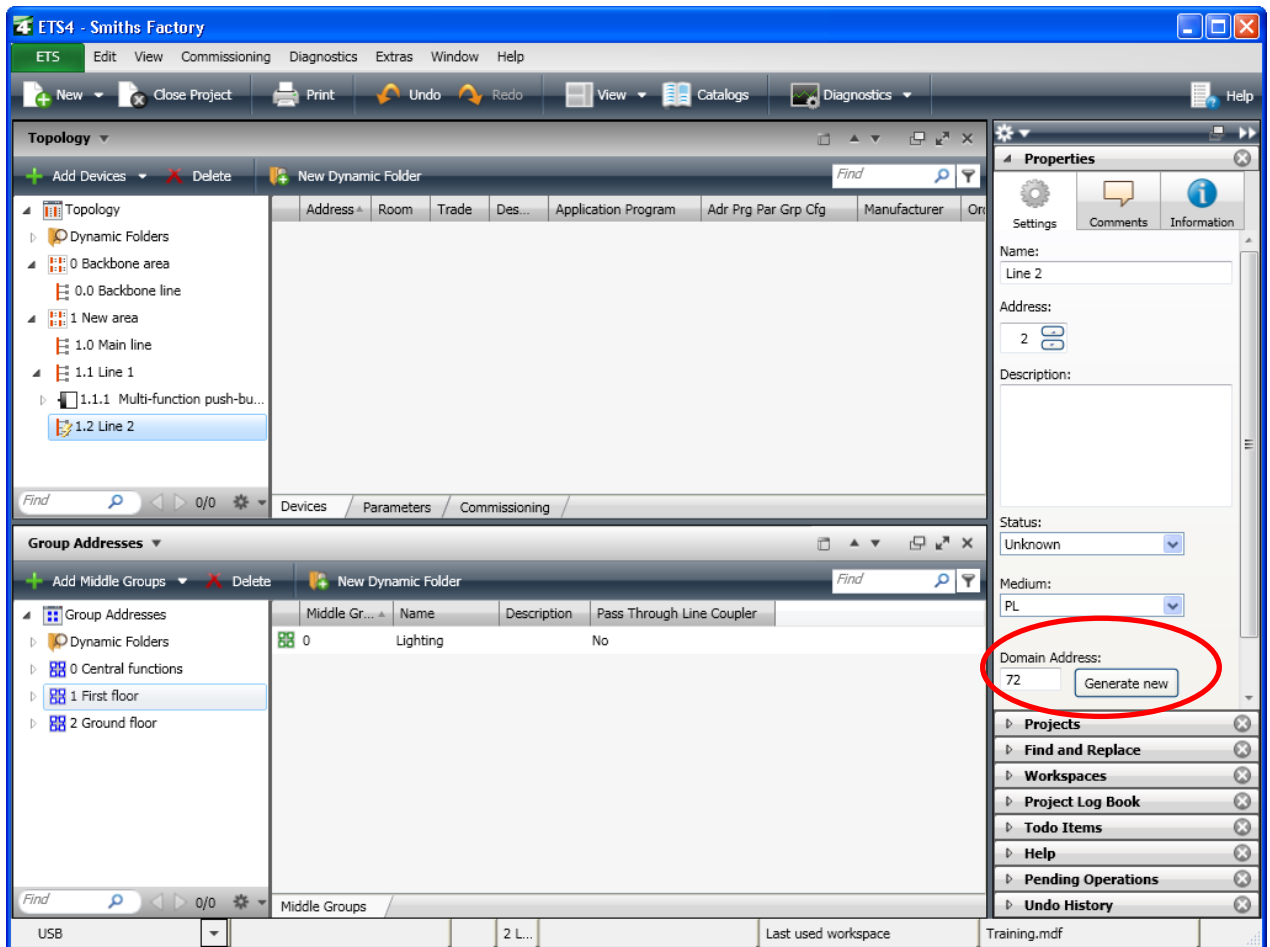

Figure 19: Checking the domain address (System ID)

## 7.3 Loading the basic configuration (setting the repeater status)

If a Powerline installation is extended by a repeater at a later date, the device must first be inserted in the ETS project from the database. ETS will subsequently reset the “Cfg” entries for all Powerline devices. All Powerline devices must be provided with the new information that a repeater has now been installed. This means that the application must be reloaded into all devices.

**Note:** It must of course also be set in the configuration menu of the local interface that a repeater is present in the installation.



# ETS4 Diagnostics

KNX Association

## Table of Contents

1	Diagnostics and fault location.....	3
2	Diagnostics: Individual addresses... ..	4
2.1	Devices in Programming Mode.....	4
2.2	Checking if an address exists and locating the device .....	5
2.3	Listing all existing addresses in a line .....	5
3	Diagnostics: Device Info, reading out devices .....	8
4	Diagnostics: Bus monitoring and Group monitoring.....	10
4.1	Starting and stopping a telegram recording .....	11
4.2	Bus Monitoring .....	11
4.3	Group monitoring.....	12
4.4	Properties of individual telegrams.....	14
4.5	Options for telegram recording .....	16
4.5.1	General .....	16
4.5.2	Recording.....	17
4.5.3	Colouring.....	18
4.5.4	Conditions .....	19
4.6	Saving telegrams.....	19
4.7	Opening telegrams from file.....	20
4.8	Clearing the telegram list.....	20
4.9	Replaying telegrams.....	22
5	Group addresses: Read value.....	23
6	Group addresses: Write value .....	24
7	Diagnostics: Project Check .....	25
7.1	Device Check .....	26
7.2	Group Address Check .....	26
7.3	Topology Check .....	27
7.4	Product Information Check .....	27
8	Diagnostics: Online Error Diagnostics .....	28
9	Diagnostics: Online Installation Diagnostics Wizard .....	32
10	Diagnostics: Tool Diagnostics .....	34

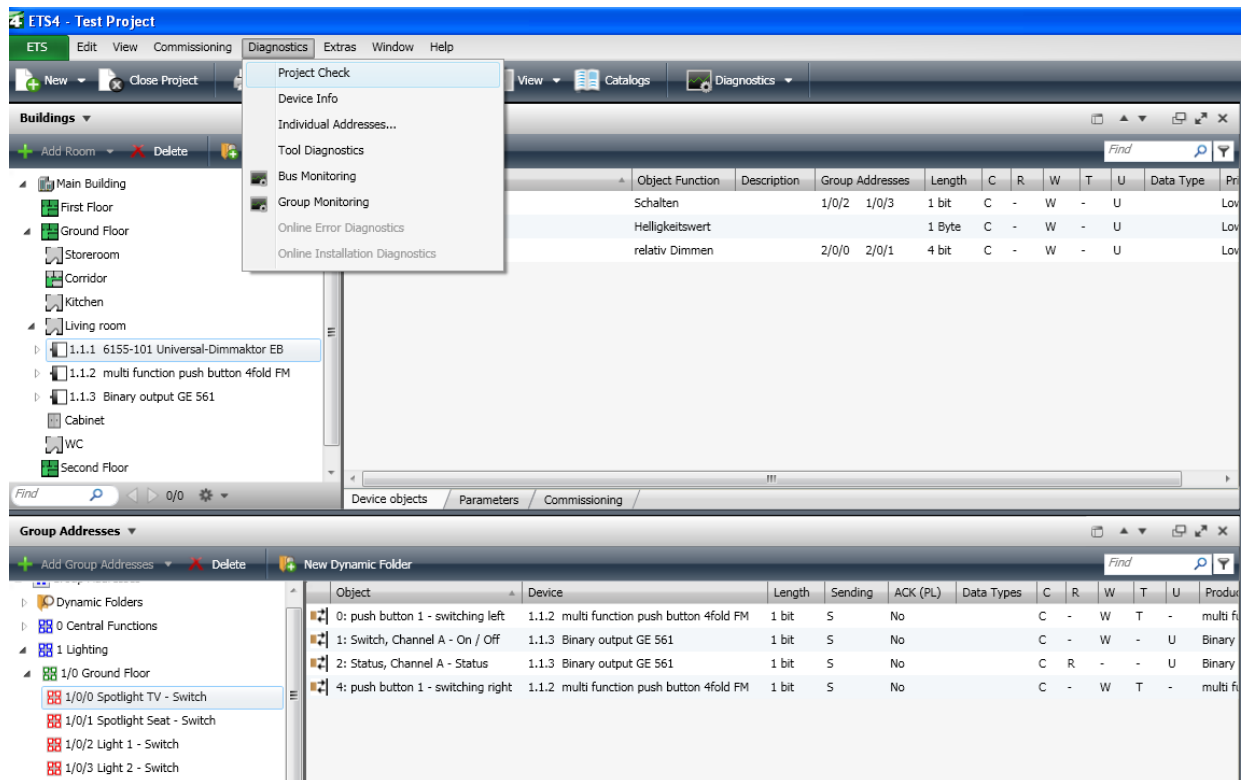

Figure 1: Diagnostics and fault location

## 1 Diagnostics and fault location

If a KNX installation does not function optimally, errors shall be localized as quickly as possible and rectified. When doing so, it is important to describe problems that arise as precisely as possible. Detailed and up to date documentation of the installation is vital to be able to detect such types of errors.

As the diagnostics function of ETS requires direct bus access, the PC or notebook must be connected to the KNX installation via an interface/local interface (e.g. RS232, USB or IP).

During fault location, it is extremely advisable to work systematically. First of all, it is necessary to rule out the possibility that the error is located in the electrical power system (230/400 V) of the installation (e.g. faulty luminaries) or in the cabling of the installation.

After establishing that a certain function cannot be executed, one should proceed step by step to locate the error, starting with the sending bus device (sensor) and finishing with the receiving device (actuator), in order to be able to correct the error.

Possible causes for bus devices not responding within a line can include:

- ✚ wire breakage on the bus line;
- ✚ polarity reversal of the bus line at a device;
- ✚ pre-programmed devices installed in the wrong line;
- ✚ bus devices incorrectly configured and/or parameterised;
- ✚ incorrectly programmed device;
- ✚ faulty device;

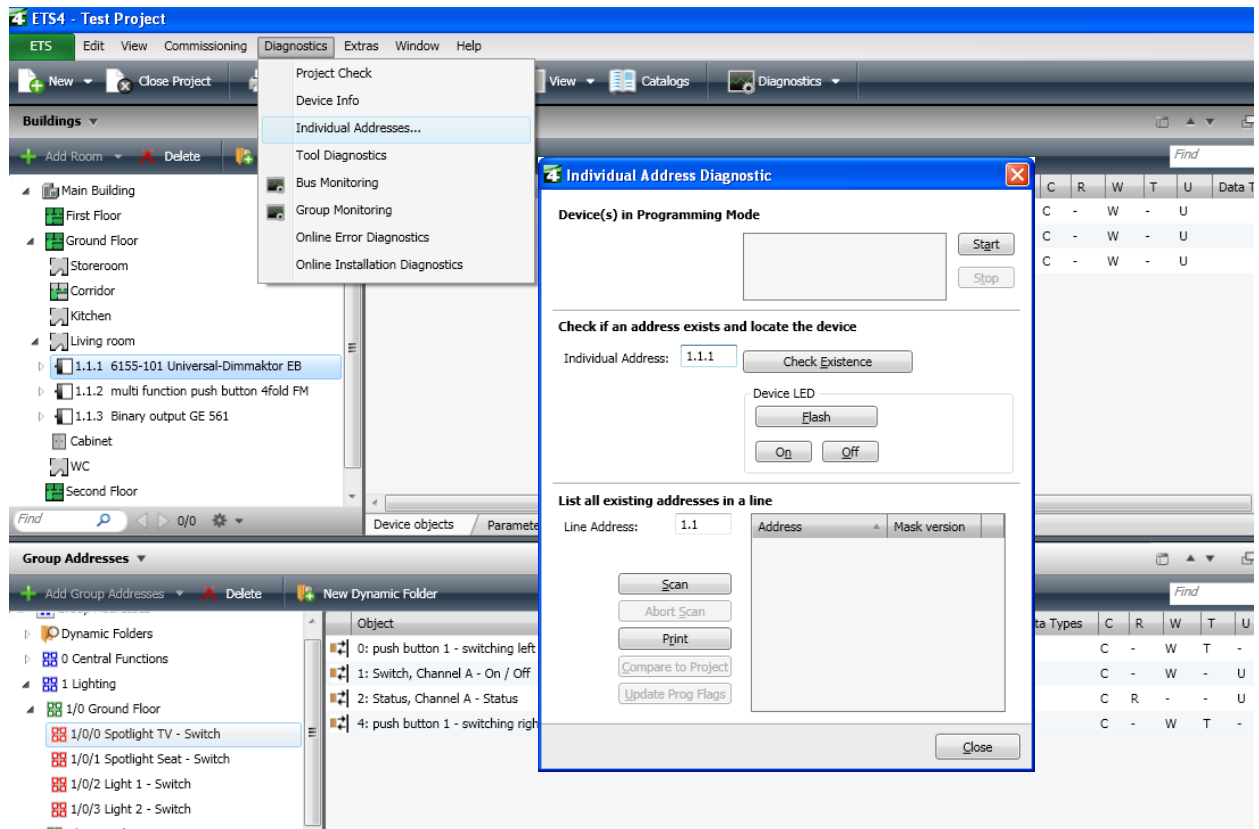

Figure 2: Diagnostics/Test: Individual addresses

## 2 Diagnostics: Individual addresses...

The diagnostics function “Individual addresses...” is used to:

- ✚ check whether devices with a specific individual address exist in the installation;
- ✚ Locate devices:
- ✚ Check whether the individual addresses in the project match those loaded in the bus couplers.

### 2.1 Devices in Programming Mode

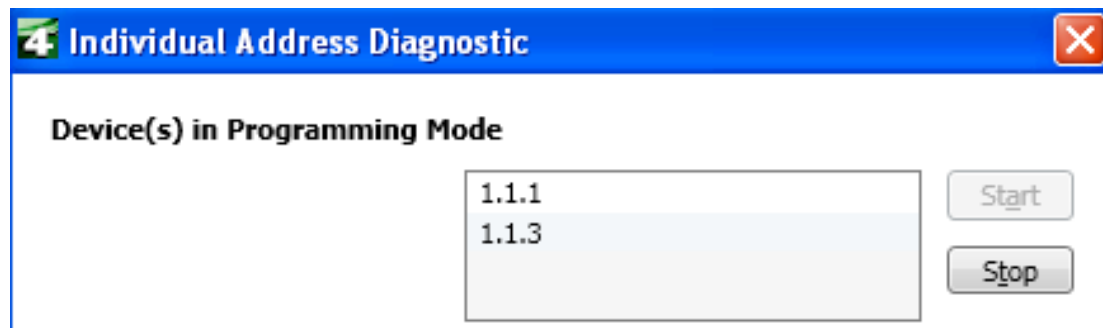

Figure 3: List all existing addresses in a line

If the programming LED of one or several devices has been switched on, the corresponding individual address(es) appear(s) in the selection window under “Device(s) in Programming mode”.

The ETS program continually checks which devices are in programming mode.

## 2.2 Checking if an address exists and locating the device

### Check if an address exists and locate the device

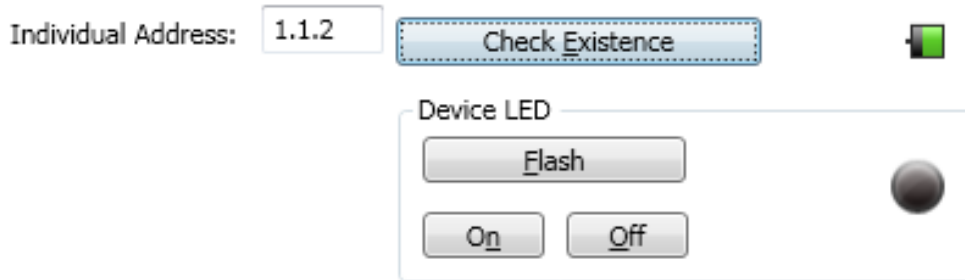

**Figure 4: Check whether individual address exists**

In order to check whether an individual address exists, enter the individual address in the field “Individual address” and press the “Check Existence” button. The ETS program indicates the following result after a short period.

### Check if an address exists and locate the device

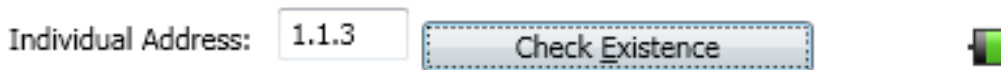

**Figure 5: Device exists**

### Check if an address exists and locate the device

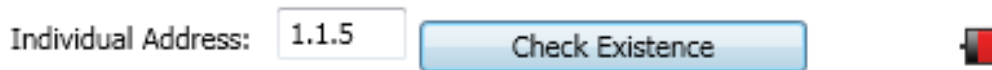
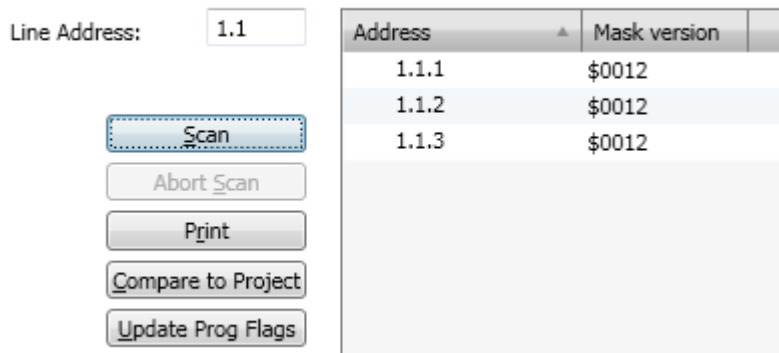

**Figure 6: Device does not exist**

Another possibility to locate a device in the installation is to have the device LED set to “Flash”, “On” or “Off” via the buttons under “Device LED”.

## 2.3 Listing all existing addresses in a line

### List all existing addresses in a line



**Figure 7: List all existing addresses in a line**

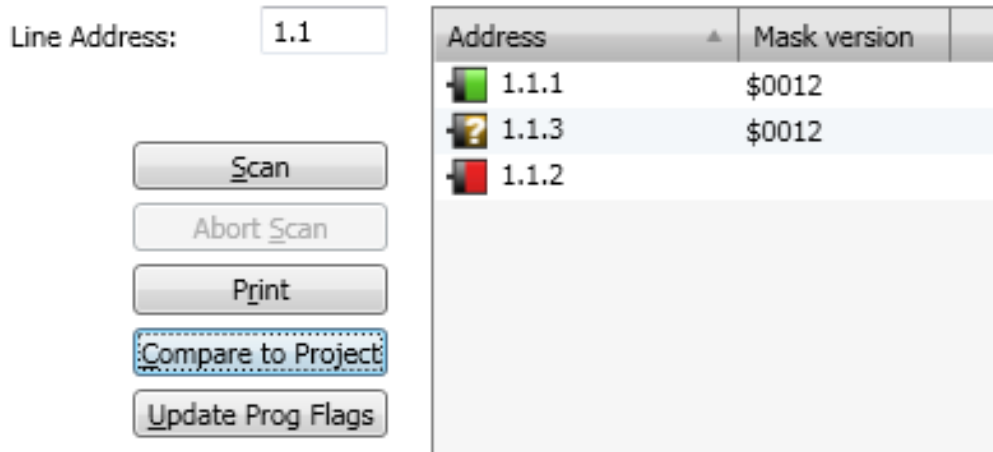

If one wishes to establish, which individual addresses have already been assigned in a line or a line segment, this can be checked via the “Scan” button. The addresses that have been found are displayed as well as the mask version of the bus coupler.

**List all existing addresses in a line**



**Figure 8: comparing addresses with project**

When the corresponding project is opened in ETS, it is possible to compare the addresses in the line with those of the project (button “Compare to Project”). The following results are possible:

-  Device found and configured in ETS **OK**
-  Device found but not configured
-  Device not found but configured

Via the button “Update Prog Flags”, the identifier “Adr” (individual address programmed) is set for all devices in the current project that were found when scanning a line.

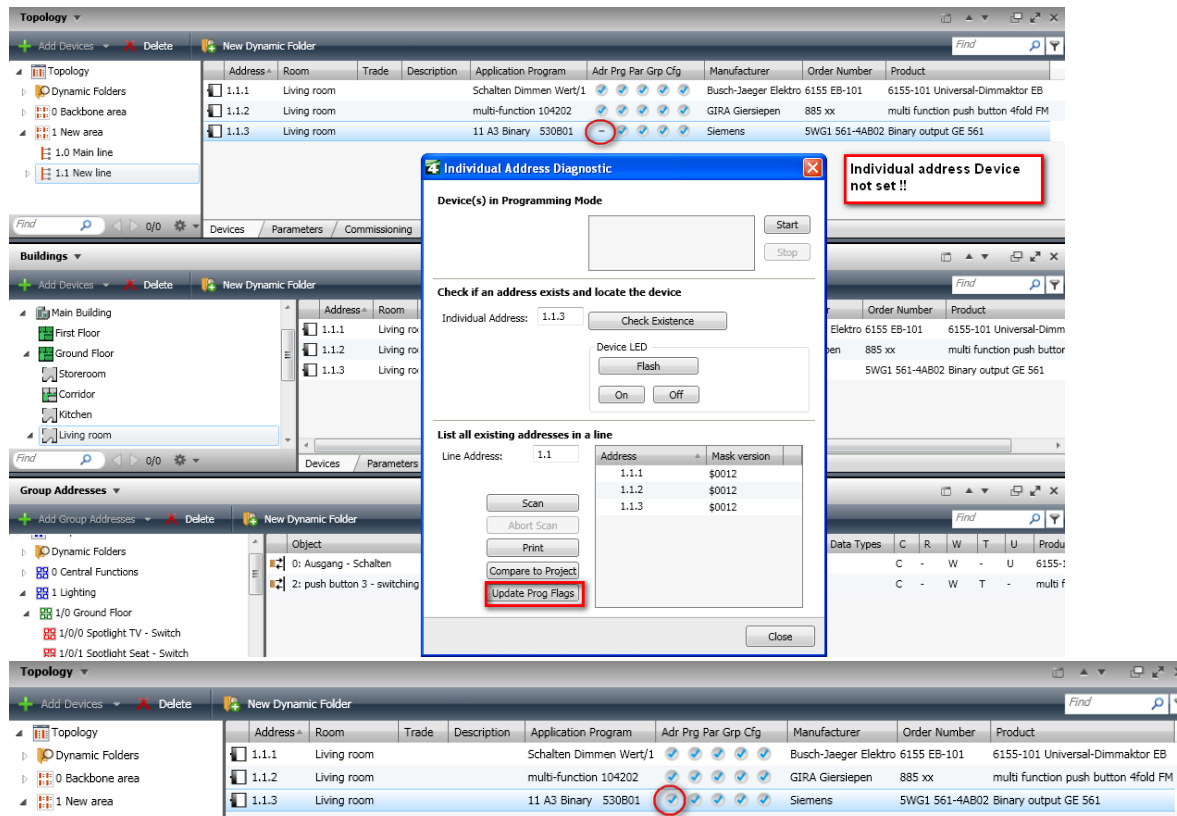

Figure 9: Update Prog. Flag

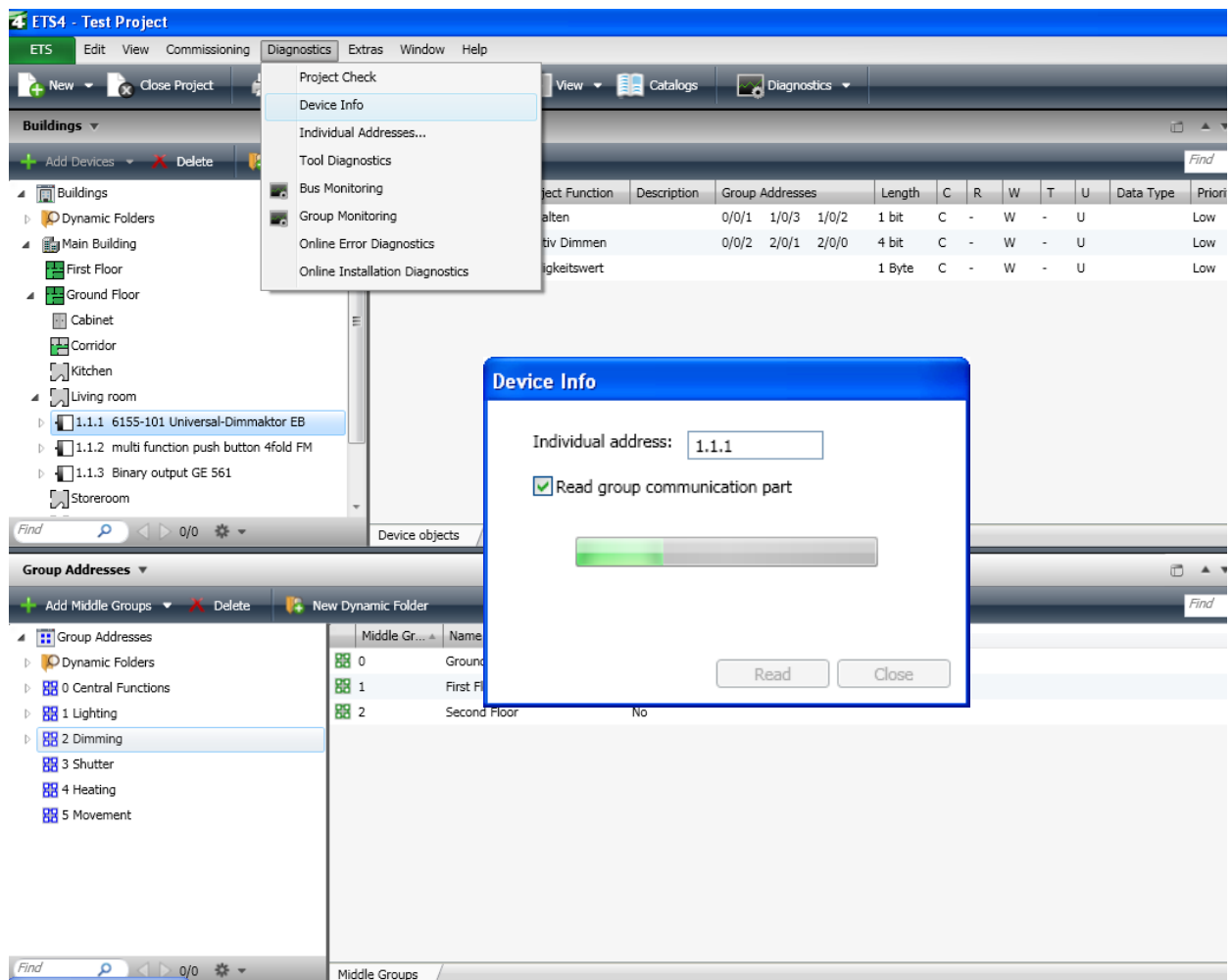

Figure 10: Device info

### 3 Diagnostics: Device Info, reading out devices

In order to check whether the correct application program has been downloaded to a bus coupler or the appropriate application module has been mounted, the commissioning engineer can make use of the diagnostics function “Device Info...”.

The function can be activated either via the main menu “Diagnostics” or via the context-sensitive menu Info / Device info (With Group Communication) or just by selecting “Device Info” in the Dashboard of ETS.

When selecting the option “Read group communication part”, the group addresses assigned to the group objects are also read out.

The reading process is started by hitting the “Read” button.

The device information is shown in formatted and unformatted form, i.e. once as numerical value and once as interpretation of the numerical value (e.g. name of manufacturer of the read device and the manufacturer code).



### Device Info of Device 1.1.1

#### General

Item	Value	Resource name	Unformatted value
Mask version	50012		18
Individual Address	1.1.1	IndividualAddress	4353
Device manufacturer	Busch-Jaeger Elektro	DeviceManufacturerId	7
Bus voltage	29.1V (=0.5V)	DeviceBusVoltage	29.1
Programming mode	Off	ProgrammingMode	false
Run Error	OK (SFF)	RunError	255
Hardware PEI type	2 inputs, 2 outputs, 1 LED	DevicePeiType	4

#### Application Program

Item	Value	Resource name	Unformatted value
Program	7 6155 99	ApplicationId	123819417
Device Type	56155	ApplicationId	24917
Version	9.9	ApplicationId	153
Run State	Running (S2E)	ApplicationRunStatus	46
Software PEI Type	2 inputs, 2 outputs, 1 LED	ApplicationPeiType	4

#### Group Communication

Item	Value	Resource name	Unformatted value
Obj#0 (1 bit,-WC-U,-Low)	0 0 1 1 0 2 1 0 3		
Obj#1 (4 bit,-WC-U,-Low)	0 0 2 2 0 0 2 0 1		
Obj#2 (1 Byte,-W--U,-Low)			

Figure 11: Content device info

If the device has been read successfully, the following information is displayed in the window “Device Info...”

#### General

<b>Mask version:</b>	Current mask version of the bus coupler
<b>Individual address</b>	Individual address of the read bus coupler
<b>Device manufacturer</b>	Name of the manufacturer of the read bus device
<b>Bus voltage</b>	Bus voltage in the bus coupler
<b>Programming mode</b>	Status of the programming LED
<b>Run error</b>	Error while executing the program in the bus coupler (if no error ->OK)
<b>Hardware PEI type</b>	Adapter type of the hardware

#### Application Program

<b>Program</b>	The ID of the application, consisting of the “Manufacturer ID” of the device manufacturer, “Device Type” and the “Version”
<b>Device type</b>	Manufacturer-specific application number typically stored in the device memory
<b>Version</b>	Version number of the application
<b>Run state</b>	status of the application program
<b>Software PEI type</b>	Designation of the configured adapter type (if PEI type = 01, then invalid adapter type)

<b>Group Communication</b>	(if “Read group communication part” was selected)
Per group object	Indication of the object number; in brackets the object size, the set flags and the priority of the group object as well as all the group addresses assigned to the group object

If errors occur when executing “Device info”, which are not remedied by renewed downloading of the KNX device, one should contact the hotline of the relevant manufacturer.

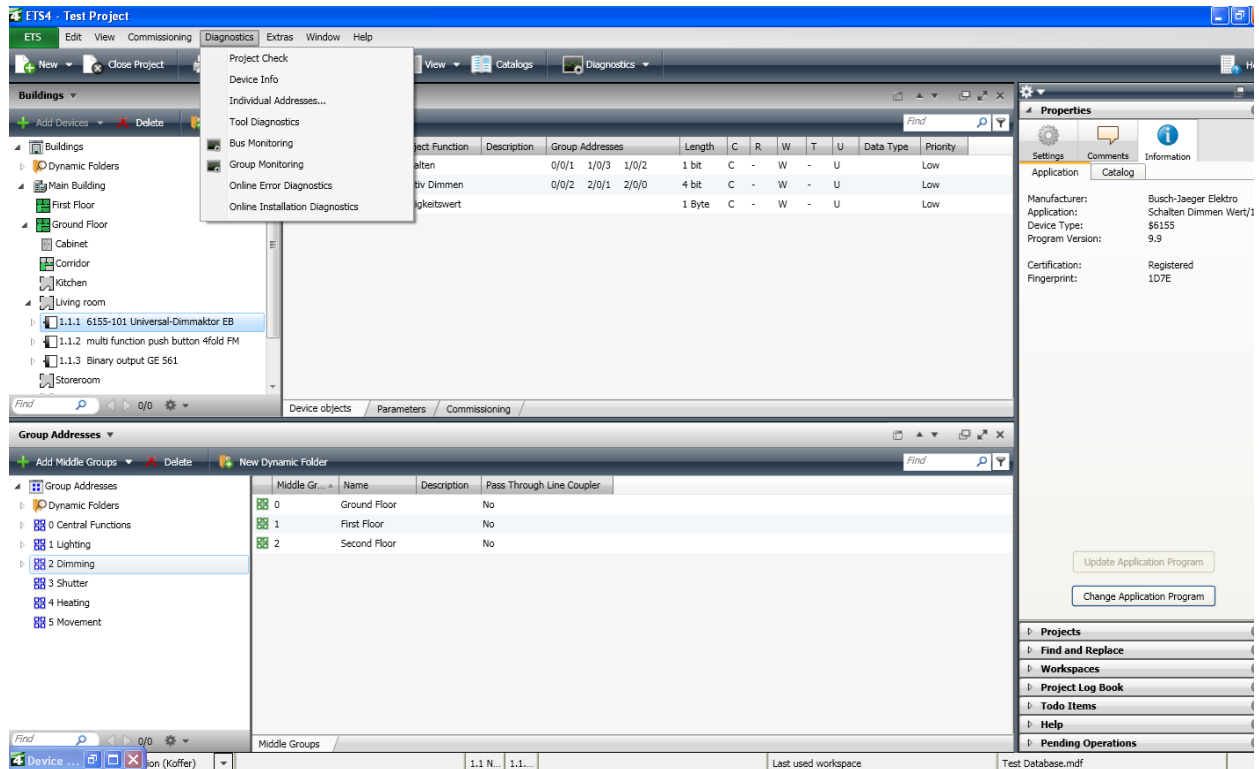

Figure 12: Bus monitoring and Group monitoring

## 4 Diagnostics: Bus monitoring and Group monitoring

Two tools are available in ETS for the recording, displaying, analysing and sending of telegram traffic in an installation as well as for reading or sending of group address values from a PC or notebook.

**Bus monitoring:** Recording and analysis of all the telegrams on the bus

**Group monitoring:** Recording and analysis of group telegrams.  
Reading and sending of group address values

The “Bus monitoring” and “Group monitoring” diagnostic functions are available via the menu item “Diagnostics” or via the tools bar.

## 4.1 Starting and stopping a telegram recording

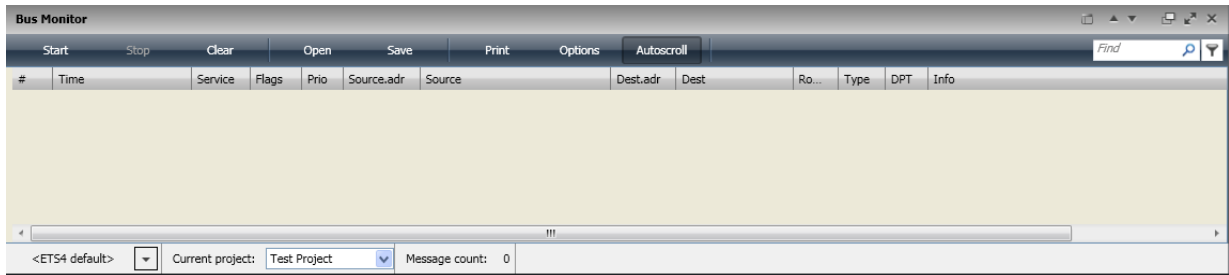

**Figure 13: Bus monitoring**

By clicking the “Start” button, the ETS program will activate the connection to the bus, making it possible to record and play telegrams.

During telegram recording, the “Start” button is greyed. By clicking with the mouse on the “Stop” button, the KNX connection is again closed and recording is stopped.

By selecting your project (in this case “Test Project”) in the field “Current Project” the device descriptions for the individual addresses as well as the designations of the group addresses are displayed in the recording, provided the corresponding project has been opened in ETS. When project data is not available, one should select one of the “no project -..” options.

In the status bar at the left hand side it is possible to set the type of connection between the PC and the KNX installation (ETS default, PEI16, USB...). Setting the connection is only possible in offline mode (no recording started).

## 4.2 Bus Monitoring

The bus monitor requires an own exclusive bus access for the duration of the recording.

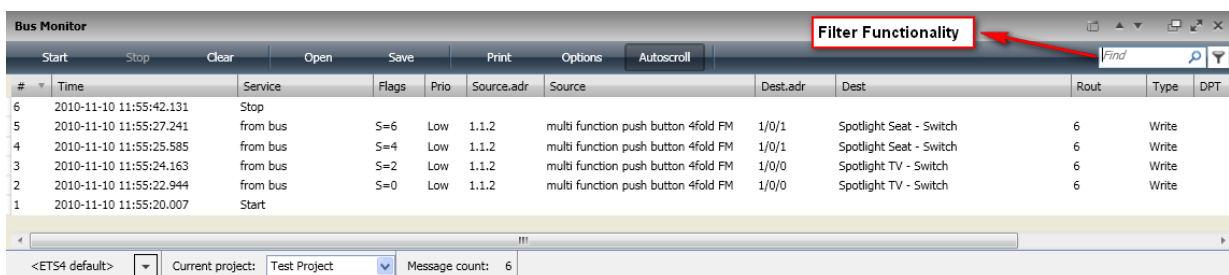

**Figure 14: Bus monitoring – filter functionality**

The ETS program shows the information about the recorded telegrams in the form of a table. The width and the arrangement of the columns can be modified. It is moreover possible to filter for specific information. Only information complying with the filter criteria entered in the right upper field will be displayed in the bus monitor window.

The following information is displayed:

<b>#</b>	Telegram number
<b>Time</b>	Time and date of the telegram (computer time!)
<b>Service</b>	received from or sent to the bus/start and stop of the trace
<b>Flags</b>	Additional information (data package nr.,...)
<b>Prio</b>	Priority of the telegram

<b>Source.adr.</b>	Source address (individual address of the sender)
<b>Source</b>	Descriptive text of the sender (if available) Only visible when in “Current project” corresponding project is selected
<b>Dest.adr.</b>	Target address (individual address when programming, group address in normal bus operation)
<b>Dest</b>	Name of the group address (subgroup) Only visible when in “Current project” corresponding project is selected
<b>Rout</b>	Value of the routing counter
<b>Type</b>	Telegram type (Write, Read...)
<b>DPT</b>	Data point type of the sending group object
<b>Info</b>	Useful data of the telegram (preceded by \$ sign -> hexadecimal or given according to DPT type definition - if DPT was set in project)
<b>ACK</b>	Acknowledgement

### 4.3 Group monitoring

During the diagnostics function “Group Monitoring”, other ETS functions accessing the bus are still possible. The diagnostic function “Group Monitoring” does not need an exclusive use of the connected interface as is the case for the function “Bus Monitoring”.

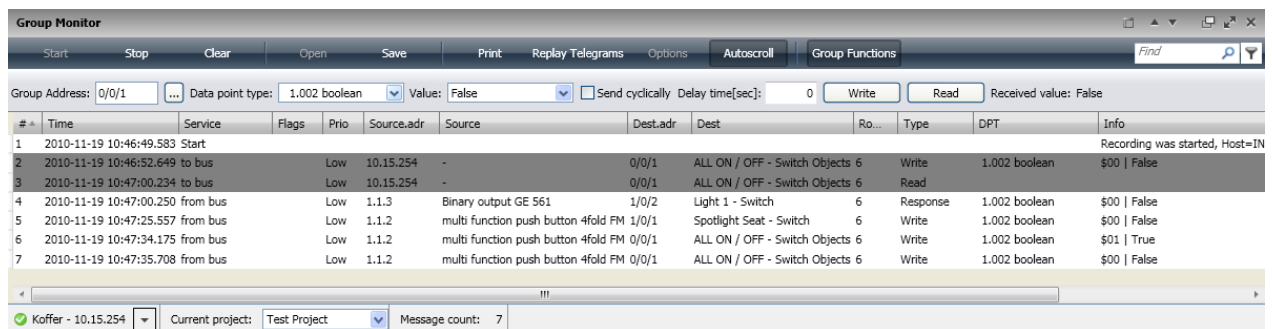

#	Time	Service	Flags	Prio	Source.adr	Source	Dest.adr	Dest	Ro...	Type	DPT	Info
1	2010-11-19 10:46:49.583	Start										Recording was started, Host=IN
2	2010-11-19 10:46:52.649	to bus		Low	10.15.254	-	0/0/1	ALL ON / OFF - Switch Objects 6		Write	1.002 boolean	\$00   False
3	2010-11-19 10:47:00.234	to bus		Low	10.15.254	-	0/0/1	ALL ON / OFF - Switch Objects 6		Read		
4	2010-11-19 10:47:00.250	from bus		Low	1.1.3	Binary output GE 561	1/0/2	Light 1 - Switch	6	Response	1.002 boolean	\$00   False
5	2010-11-19 10:47:25.557	from bus		Low	1.1.2	multi function push button 4fold FM	1/0/1	Spotlight Seat - Switch	6	Write	1.002 boolean	\$00   False
6	2010-11-19 10:47:34.175	from bus		Low	1.1.2	multi function push button 4fold FM	0/0/1	ALL ON / OFF - Switch Objects 6		Write	1.002 boolean	\$01   True
7	2010-11-19 10:47:35.708	from bus		Low	1.1.2	multi function push button 4fold FM	0/0/1	ALL ON / OFF - Switch Objects 6		Write	1.002 boolean	\$00   False

Figure 15: Group monitoring

The following information is displayed:

<b>#</b>	Telegram number
<b>Time</b>	Time and date of the telegram (computer time!)
<b>Service</b>	received from or sent to the bus/start and stop of the trace
<b>Flags</b>	Additional information (data package nr. ...)
<b>Prio</b>	Priority of the telegrams
<b>Source.adr.</b>	Source address (individual address of the sender)
<b>Source</b>	Descriptive text of the sender (if available) Only visible when in “Current project” corresponding project is selected
<b>Dest.adr.</b>	Target address (individual address when programming, group address in normal bus operation)
<b>Dest</b>	Name of the group address (subgroup)

	Only visible when in “Current project” corresponding project is selected
<b>Rout</b>	Value of the routing counter
<b>Type</b>	Telegram type (Write, Read .)
<b>DPT</b>	Data point type (DPT)
<b>Info</b>	Useful data of the telegram (preceded by \$ sign -> hexadecimal or given according to DPT type definition - if DPT was set in project)

The acknowledgement (ACK,...) is not shown in the “Group Monitoring” function.

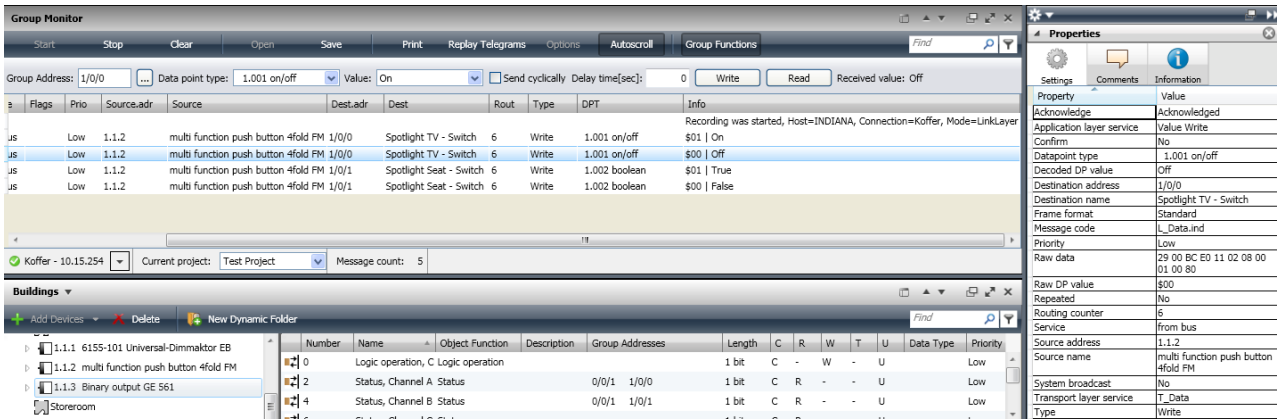

Figure 16: Telegram properties

### 4.4 Properties of individual telegrams

By marking a specific telegram in the list it is possible to display the telegram information in extended format in the “Properties” window. The different properties can be sorted alphabetically when clicking on the Property header

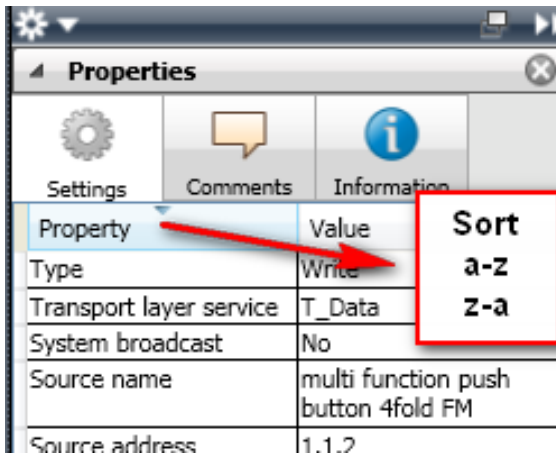

Figure 17: Sorting telegram properties

Depending on whether the Bus monitoring or Group monitoring is used, the following information is displayed:

<b>Type</b>	read, response, write
<b>Transport Layer service</b>	T_Data, T_Connect, T_Disconnect
<b>System Broadcast</b>	yes, no
<b>Source Name</b>	Name of the sending device (if project is open)
<b>Source Address</b>	individual address of sender
<b>Service</b>	from/to bus
<b>Routing counter</b>	value of the routing counter
<b>Repeated</b>	yes/no
<b>Raw DP Value</b>	raw value of the data point
<b>Raw data</b>	Telegram in hexadecimal form
<b>Priority</b>	Low, High, Alarm, System
<b>Message code</b>	Type of service and which layer
<b>Frame format</b>	Standard/Extended
<b>Destination name</b>	Name of group address or name of addressed device

<b>Destination address</b>	Destination Group or individual address
<b>Decoded DP Value</b>	Data interpreted according Data Point Type (if project is open and if assigned)
<b>Datapoint type</b>	Name of Data point type (if project is open and if assigned)
<b>Busmonitor status</b>	sequence counter value
<b>Application Layer service</b>	type of application layer message
<b>AI</b>	Bus monitor additional information field, e.g. time stamp
<b>Acknowledge</b>	Acknowledged/not Acknowledged

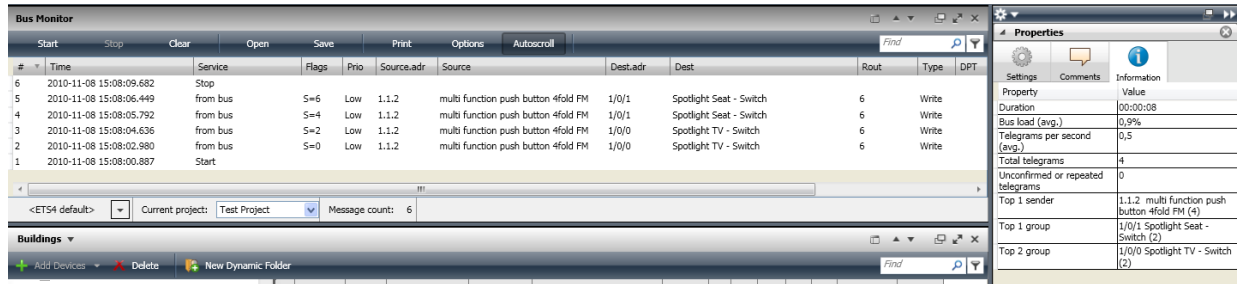

Figure 18: Telegram information

An overview of the recorded telegrams can be displayed when selecting the “Information” button in the Properties window.

<b>Duration</b>	Total duration of the recording
<b>Bus load</b>	Average bus load on the bus
<b>Telegrams per second (avg.)</b>	Average number of telegrams per second on the bus
<b>Total telegrams</b>	Total number of recorded telegrams
<b>Unconfirmed or repeated telegrams</b>	Number of unconfirmed or repeated telegrams
<b>Top x sender</b>	Source address of the device that sent the most telegrams on the bus (and how many times it did)
<b>Top x group</b>	Most used destination address (and number of times it appeared on the bus)

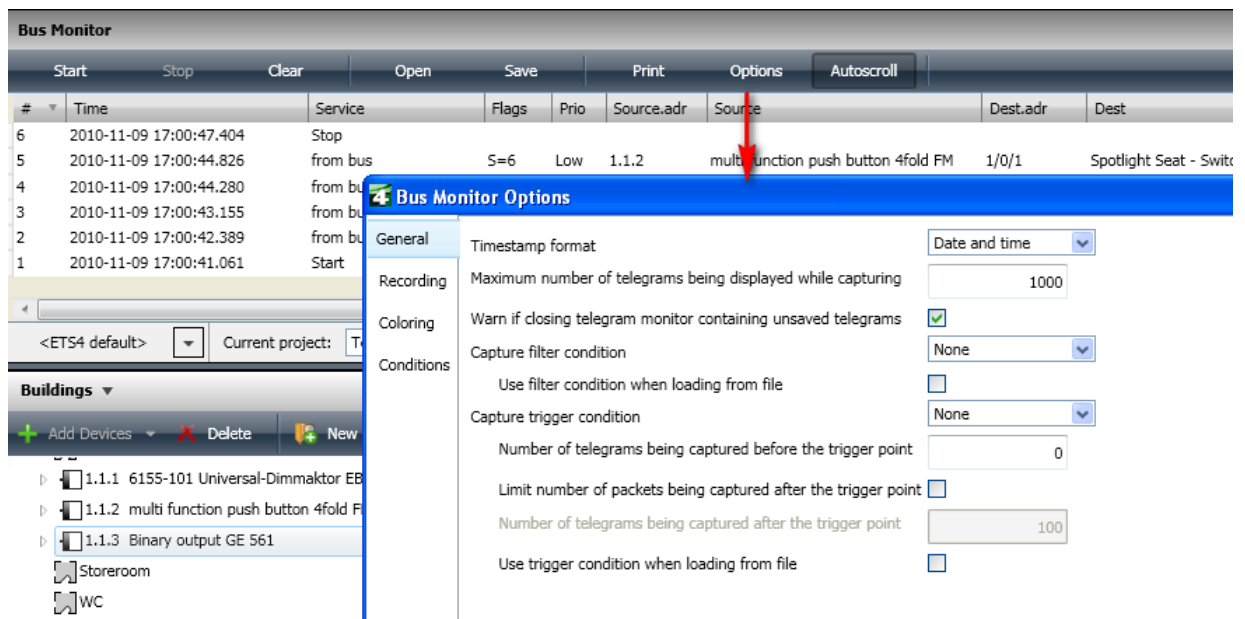

Figure 19: Options for telegram recording

## 4.5 Options for telegram recording

Telegram repetitions or faulty telegrams are displayed in ETS with a background colour. Via the “Options” button it is possible to modify the text and background colour of the various telegrams. In order to be able to open the “Options” window, it is imperative that recording of telegrams has been stopped.

### 4.5.1 General

#### Timestamp Format:

Under the “General” tab, it is possible to select the desired format of the time stamp (date and time or time only) for the display of telegram information.

**Caution:** The time stamp is the time information of the diagnostics PC!

#### Maximum number of telegrams being displayed while capturing:

The maximum number of telegrams that can be displayed while capturing can be set here. The default value is set to 1000 telegrams.

#### Warn if closing telegram monitor containing unsaved telegrams:

When deactivating this checkbox, the program will close the monitor window without warning the user whether recorded telegrams need to be saved first.

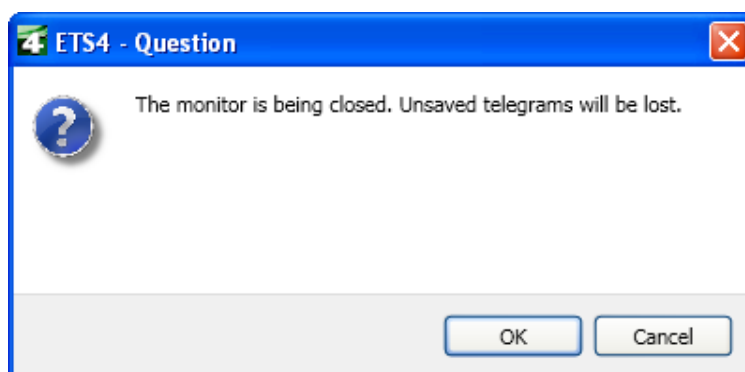

Figure 20: Unsaved telegrams will be lost



### Capture filter condition

Telegrams are filtered according to the set criteria (see below). When selecting the “None” options, all telegrams whether invalid, acknowledged, not acknowledged,... will be shown.

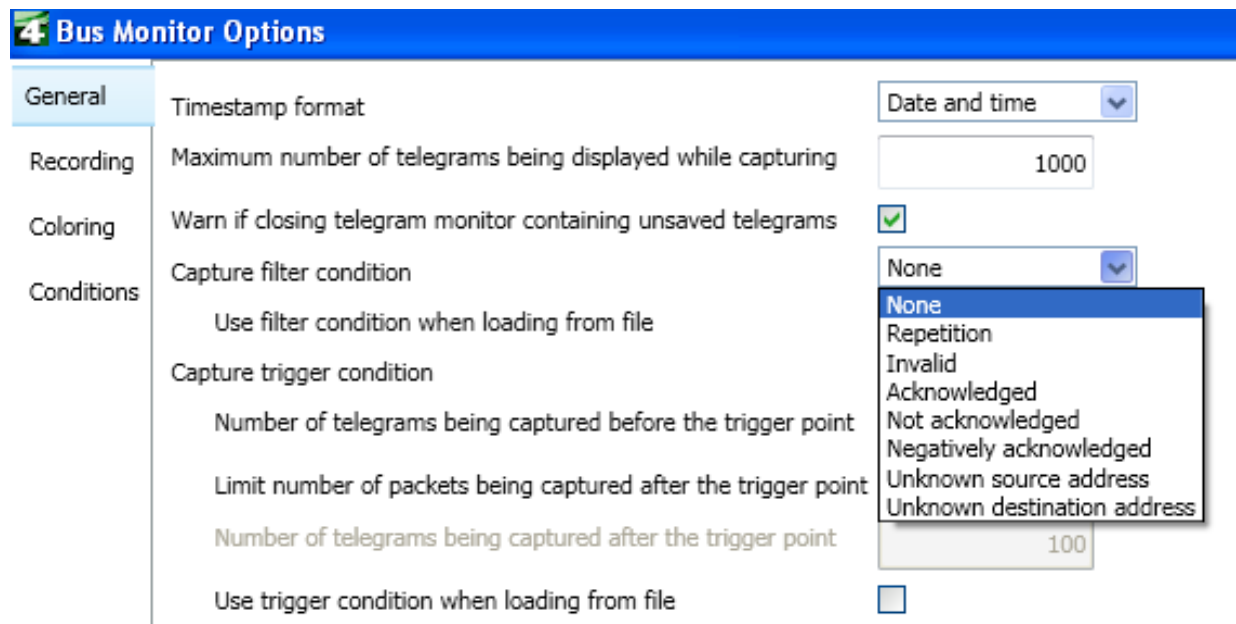

Figure 21: Capture trigger condition

### Capture trigger condition

When a specific trigger condition is set, telegrams are displayed only if the set trigger condition is met. Once can specify the number of telegrams that will be captured before the trigger condition is met as well as limit the number of packets captured after the trigger condition is met.

## 4.5.2 Recording

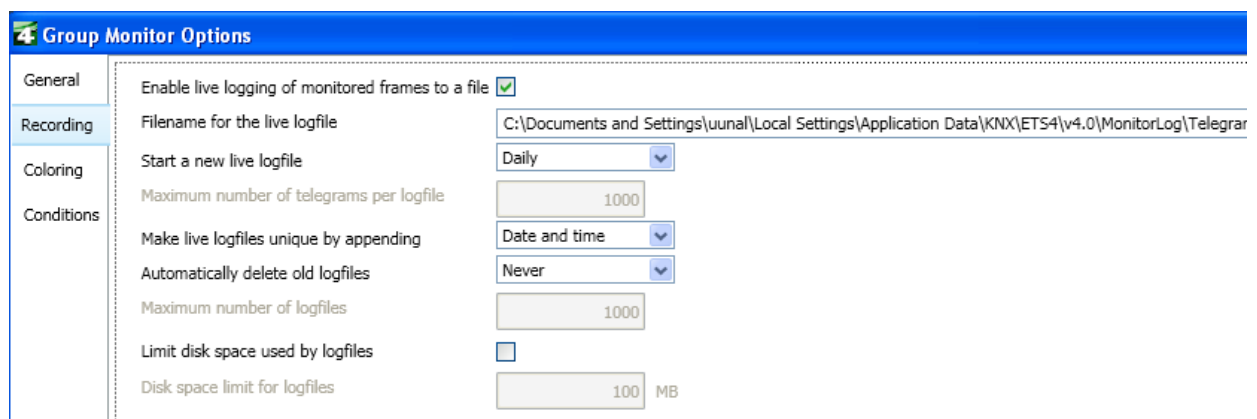

Figure 22: Options - telegram recording

Recorded telegrams can be logged to a file on your computer or on a network computer for later analysis. This is ensured by setting the field “Enable live logging of monitored frames to a file”.

In the field “Start a new log file”, it is possible to determine when ETS decides to start a new log file, i.e. based on number of the telegrams, every hour, every day, every week,

every month or every year. When selecting the “number of telegrams” option, it is possible to enter a value in the field underneath.

The name of the log files can be made unique by appending either “Date and time”, “Date and consecutive number”, “Date only” or just “Consecutive number”. By setting the option “Automatically delete old log files” one can determine whether or not old log files should be deleted. If the option “Based on number of files” is selected the field “Maximum number of log files” is enabled.

Example: Enter “3” in the field “Maximum number of log files” and start a telegram recording session 4 times. The ETS will first create the following files:

- 1) Telegrams 2010-11-16\_142814.xml (whereby 14 = hour, 28 = minutes, 14 = seconds)
- 2) Telegrams 2010-11-16\_143012.xml
- 3) Telegrams 2010-11-16\_143142.xml

Upon starting the 4th recording session, the 1<sup>st</sup> and oldest telegram recording (i.e. 142814.xml) will be deleted and a new log file will be created, i.e. Telegrams 2010-11-16\_143214.xml.

### 4.5.3 Colouring

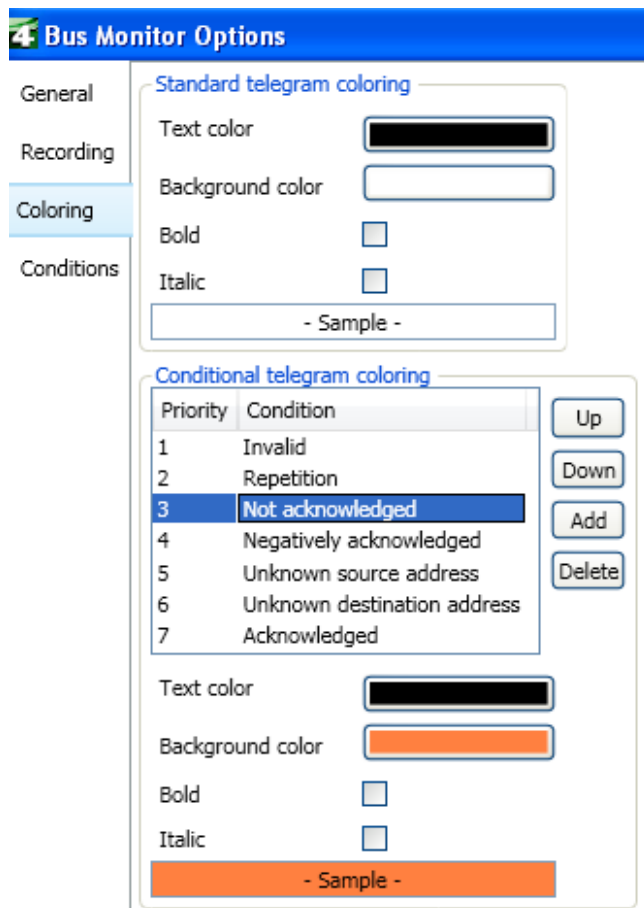

The text and background colour of invalid, not acknowledged, acknowledged telegrams can be set here.

Figure 23: Telegram colouring

### 4.5.4 Conditions

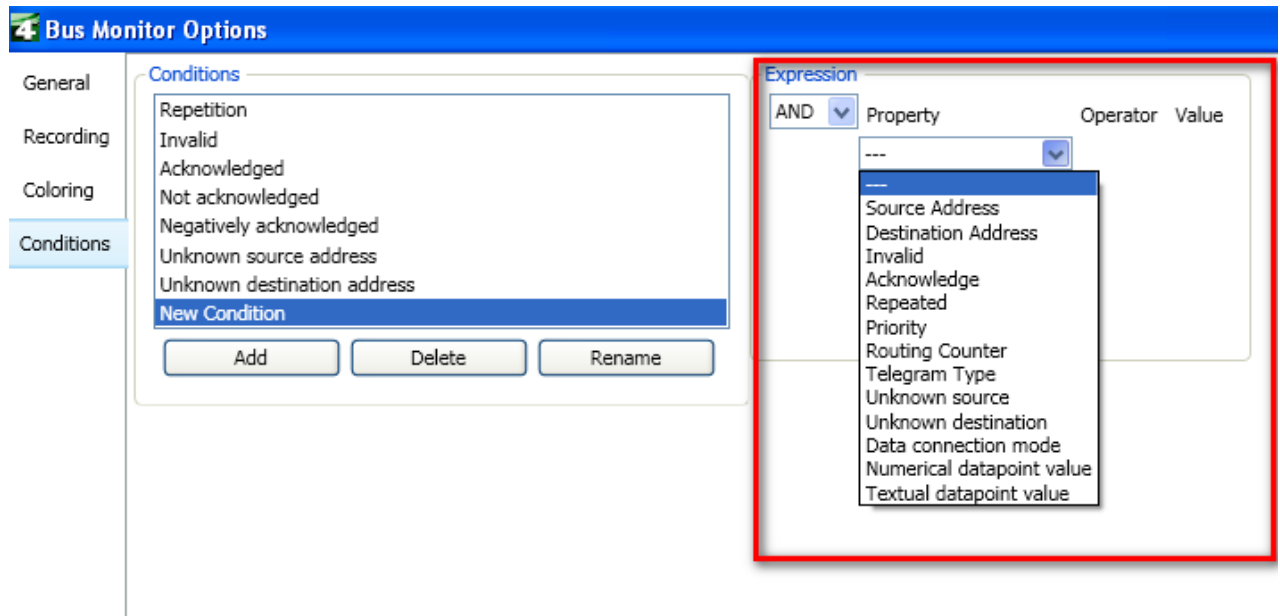

Figure 24: Options - Conditions

It is possible to add more conditions to the default set of recording conditions. The conditions can be ANDed or ORed. When e.g. selecting “source address” it is possible to filter telegrams on a specific individual address. This filter however has no influence on the recording of telegrams, but only on which telegrams are displayed. With this option, the commissioning engineer can determine the number of telegrams that are displayed, a useful function especially in larger installations with higher bus traffic. Per default ETS displays all telegrams.

#	Time	Service	Flags	Prio	Source.adr	Source	Dest.adr	Dest
2	2010-11-16 15:46:41.721	from bus	S=0	Urgent	1.1.2	multi function push button 4fold FM	1/0/0	Spotlight TV - Switch
3	2010-11-16 15:46:42.940	from bus	S=2	Urgent	1.1.2	multi function push button 4fold FM	1/0/0	Spotlight TV - Switch
4	2010-11-16 15:46:43.642	from bus	S=4	Low	1.1.2	multi function push button 4fold FM	1/0/1	Spotlight Seat - Switch
5	2010-11-16 15:46:44.267	from bus	S=6	Low	1.1.2	multi function push button 4fold FM	1/0/1	Spotlight Seat - Switch
6	2010-11-16 15:46:45.970	from bus	S=0	Low	1.1.2	multi function push button 4fold FM	0/0/1	ALL ON / OFF - Switch Objects
7	2010-11-16 15:46:46.860	from bus	S=2	Low	1.1.2	multi function push button 4fold FM	0/0/1	ALL ON / OFF - Switch Objects
8	2010-11-16 15:46:49.515	Stop						

Figure 25: Saving telegrams

### 4.6 Saving telegrams

Recorded telegrams can be saved via the menu “Save” in the toolbar of the monitor window. ETS will prompt to save either “all telegrams” or “only the selected telegrams”. The file extension is xml, allowed to edit the stored telegrams by means of an xml editor.

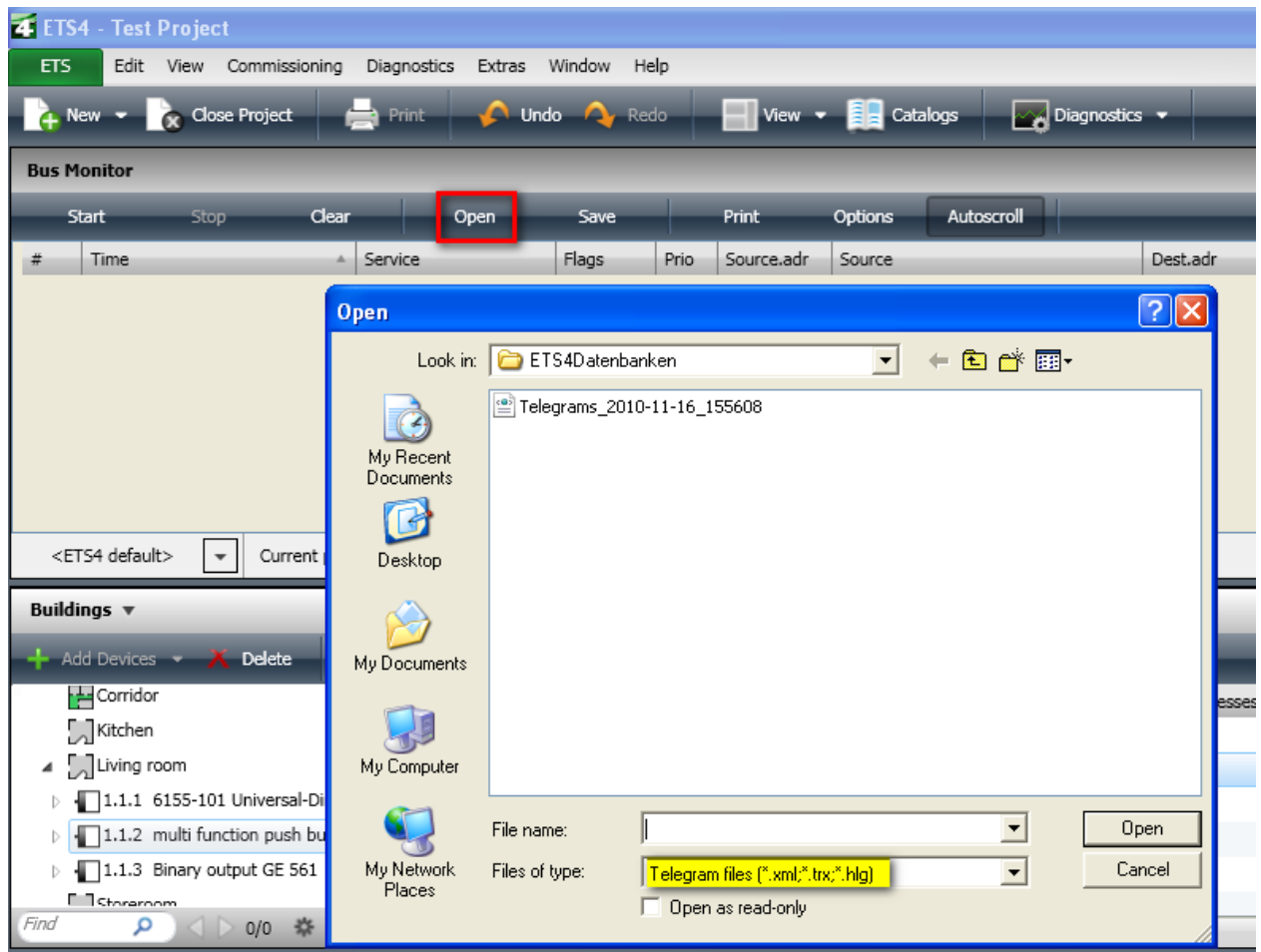

Figure 26: Opening telegrams from file

### 4.7 Opening telegrams from file

Saved telegram recordings can be opened via the menu “Open” in the toolbar of the monitor window. ETS can display files with the extensions “\*.xml,\*.trx (ETS3) or \*.hlg (ETS 2).

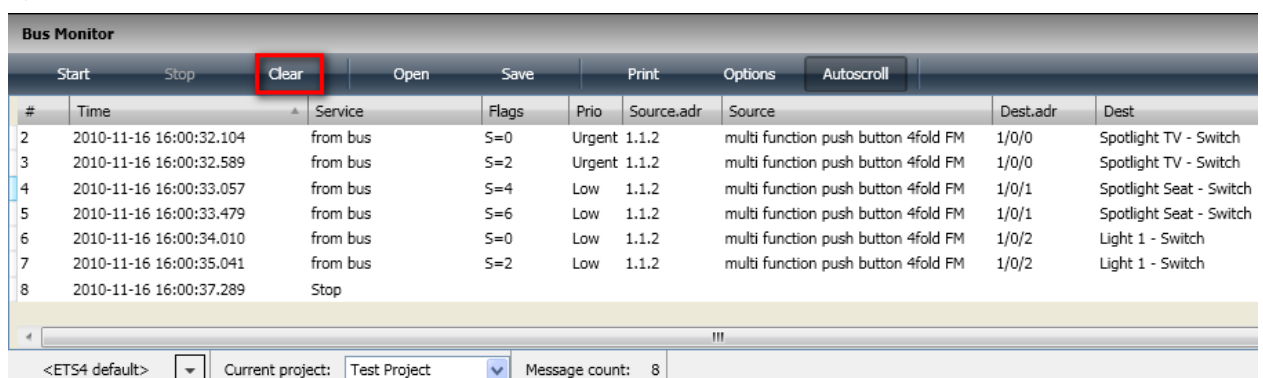

Figure 27: Clearing the telegram list

### 4.8 Clearing the telegram list

The list of previously recorded telegrams can be deleted via menu “Clear” in the toolbar of the monitor window, e.g. to start a new recording.

When deleting the recorded telegrams ETS will prompt that any unsaved telegrams will be lost (provided the relevant check box in Options/General has been set).

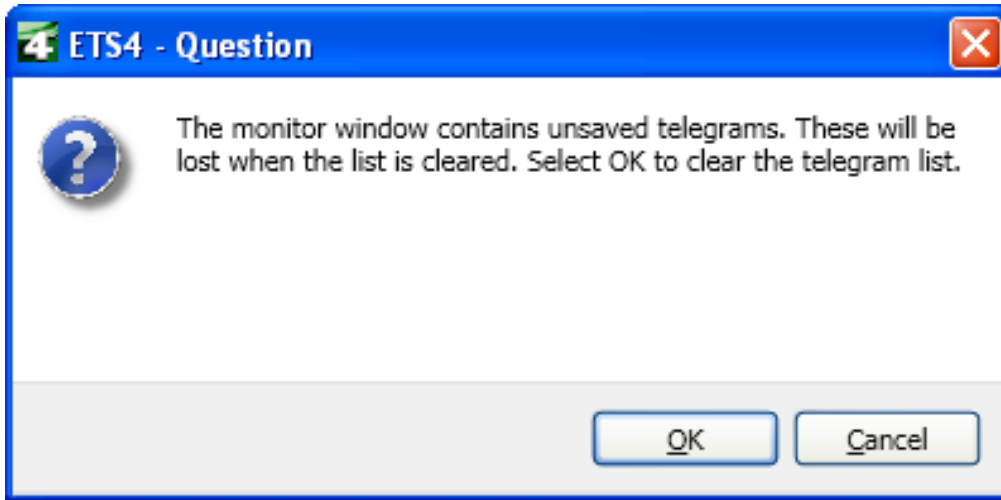

Figure 28: Warning for deleting telegrams

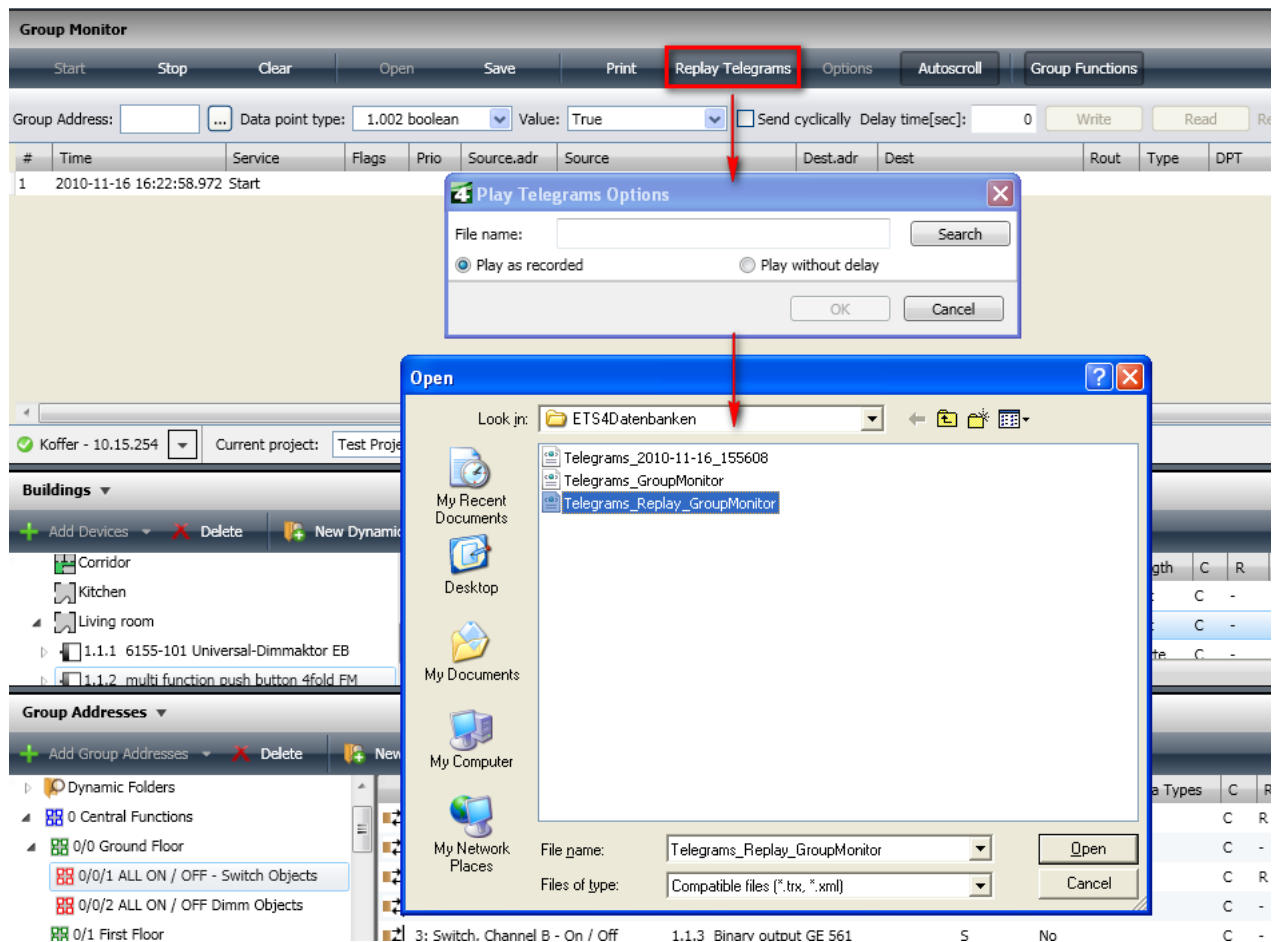

Figure 29: Select telegram file for replaying

### 4.9 Replaying telegrams

In order to verify more complex processes, ETS also allows replaying telegrams previously recorded and saved to file. This is only possible using the “Group Monitoring” function.

In order to replay the recorded telegrams, make sure that the PC is connected to the bus and hit the “Replay Telegrams” button. The “Play Telegrams Options” window is opened: the file that shall be replayed must be entered in the “File name” field or must be selected via the “Search” button.

The time regime can also be specified. It is possible to play the telegrams “as recorded” or “without delay”. The option “without delay” is the best option, when time interval between recorded telegrams is longer in the selected file.

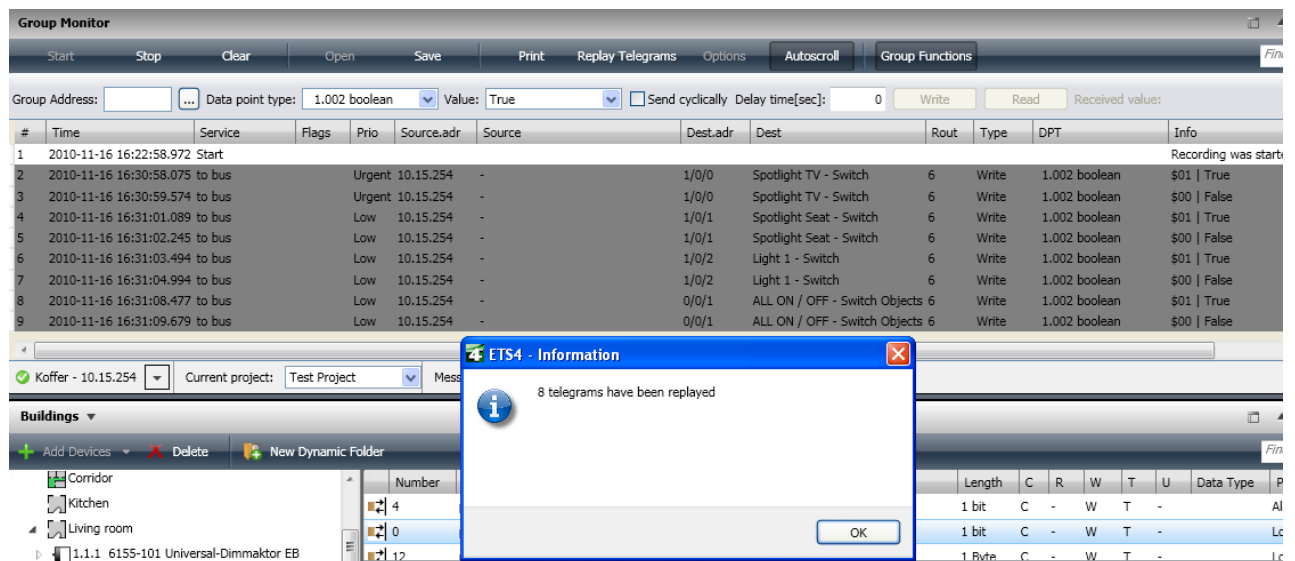

Figure 30: Replaying telegrams

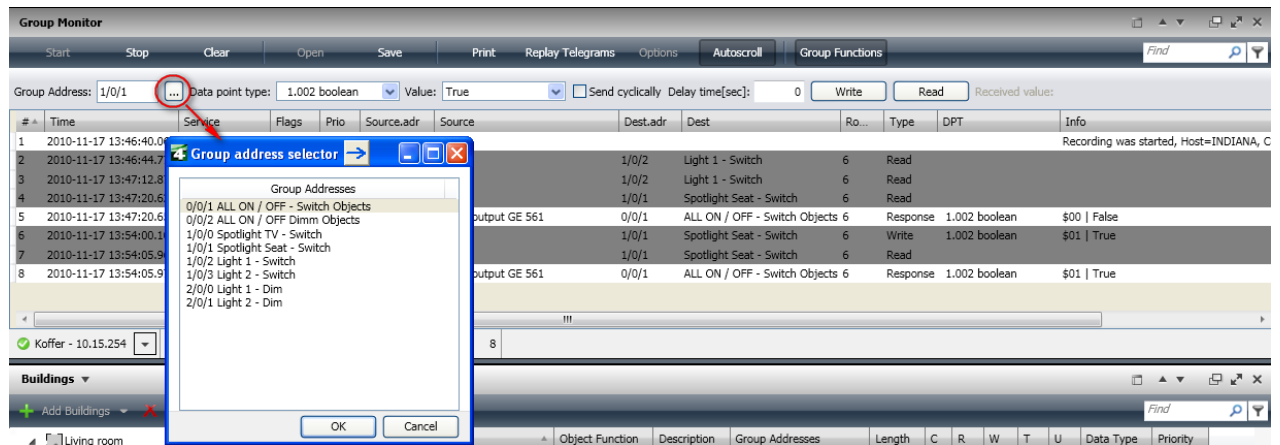



Figure 31: Group addresses: Read value

## 5 Group addresses: Read value

The diagnostics function “Group Monitoring” also offers the possibility of reading the current status of a group object.

Select the menu Diagnostics / Group Monitoring and hit the “Start” button. Click on the field ‘Group Functions’. A group address can be entered in the field “Group Address” or

selected via the symbol  from the list of existing group addresses in the current project.

A read request is sent on the bus via the “Read” button: the resulting telegram shows the type “Read’ in the column ‘Type’ AND does not show any value in the “Info” column. The indicated source address is the individual address of the interface to the bus. The value of the response telegram (Column “Type” indicates “Response”) is displayed in the “Info” column.

Values with a preceding \$ sign are hexadecimal values.

If a datapoint type (DPT) has been set in the project for the group object with the queried group address, the values are interpreted on the basis of the corresponding DPT standard, e.g. DPT\_Switch (1.001) -> On/Off.

It is only possible to read out group objects for which the read flag has been set. If group addresses are queried, which are not specified as sending group addresses in the group objects, the reply will be send with a different group address (the allocated sending one) than the one used in the read request.

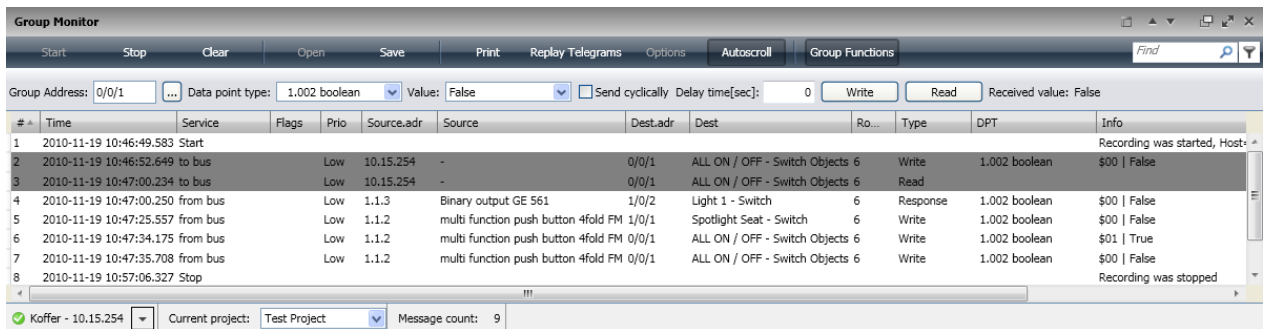



Figure 32: Group addresses: Send value

## 6 Group addresses: Write value

The diagnostics function “Group Monitoring” also offers the possibility to overwrite the current status of a group object.

Select the menu Diagnostics / Group Monitoring and hit the “Start” button. Click on the field ‘Group Functions’. A group address can be entered in the field “Group Address” or by selecting the symbol  from the list of existing group addresses in the current project.

The window also allows setting the data point type as well as the value of the useful data. Moreover, a delay can be set so that the telegram is only sent after the indicated delay. Checking the field “Send cyclically will automatically enable the “Cyclic time in sec.” option. In the latter case, a telegram will be written e.g. every two seconds.

Once the telegram has been sent, ETS shows the sent telegram and possible response telegrams in the list field.



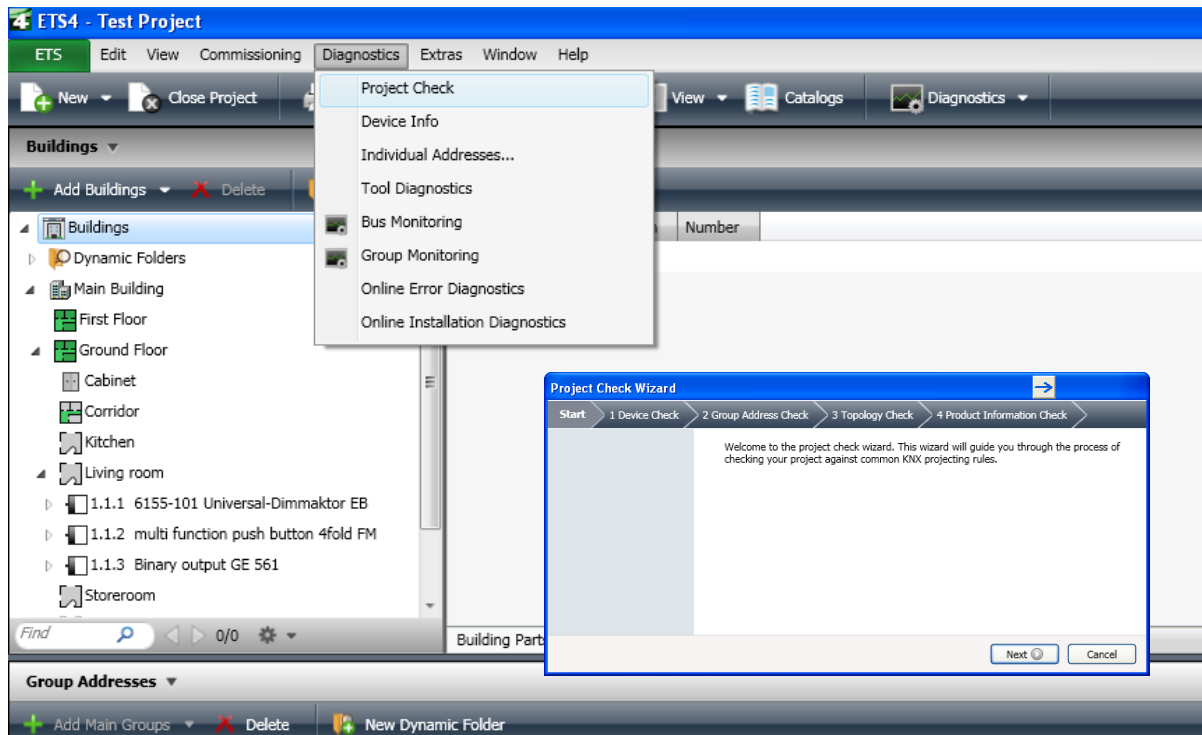

Figure 33: Diagnostics: Project Check

## 7 Diagnostics: Project Check

The “Project Check” submenu item is part of the menu “Diagnostics”. The project check wizard will guide you through the process of checking your project against common KNX planning and design rules.

Note: This is an offline test. ETS will not connect to the bus.

## 7.1 Device Check

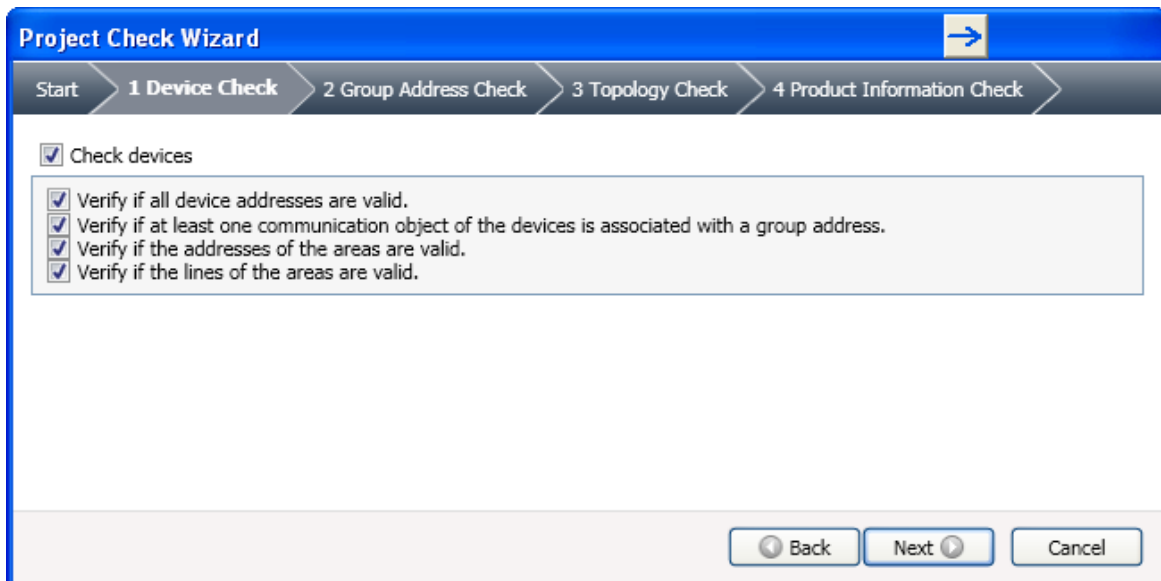

**Figure 34: Device Check**

- ✚ Was an individual address attributed to the device?
- ✚ Is this attributed individual address unique in the line?
- ✚ Does the attributed individual address correspond to the line or area, in which the device is mounted?
- ✚ Is the individual address within the range of 0 to 255?
- ✚ Have group addresses been attributed to the available group objects?

## 7.2 Group Address Check

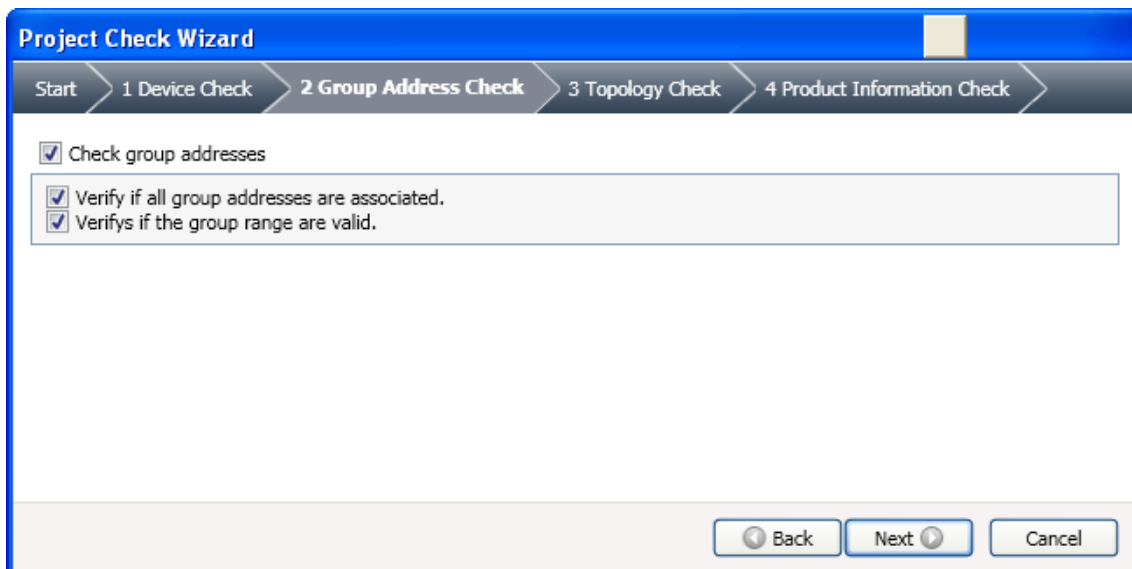

**Figure 35: Group Address Check**

- ✚ Does the group address have a correct value?
- ✚ Are all created group addressed attributed to a certain group object of a device contained in the project?

## 7.3 Topology Check

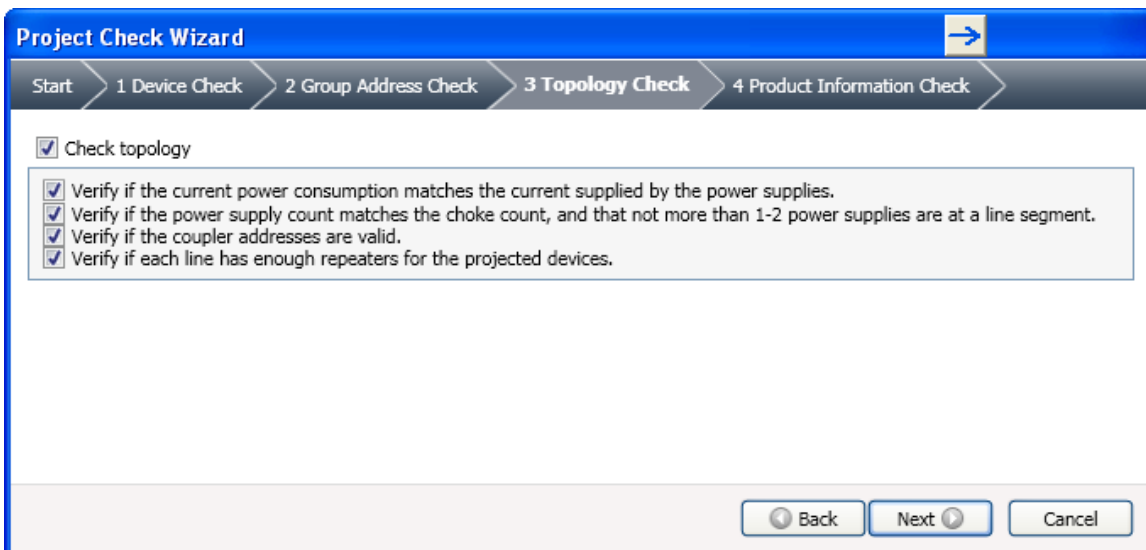

**Figure 36: Topology Check**

- ✚ Is there minimum 1 power supply, maximum two power supplies available in all line segments?
- ✚ Does the number of chokes correspond to the number of power supplies?
- ✚ Are attributed individual addresses of the line/backbone couplers correct?
- ✚ Is there a possible mismatch between actual power consumption and the current supplied by the power supply?
- ✚ Are there enough repeaters for the projected devices?

## 7.4 Product Information Check

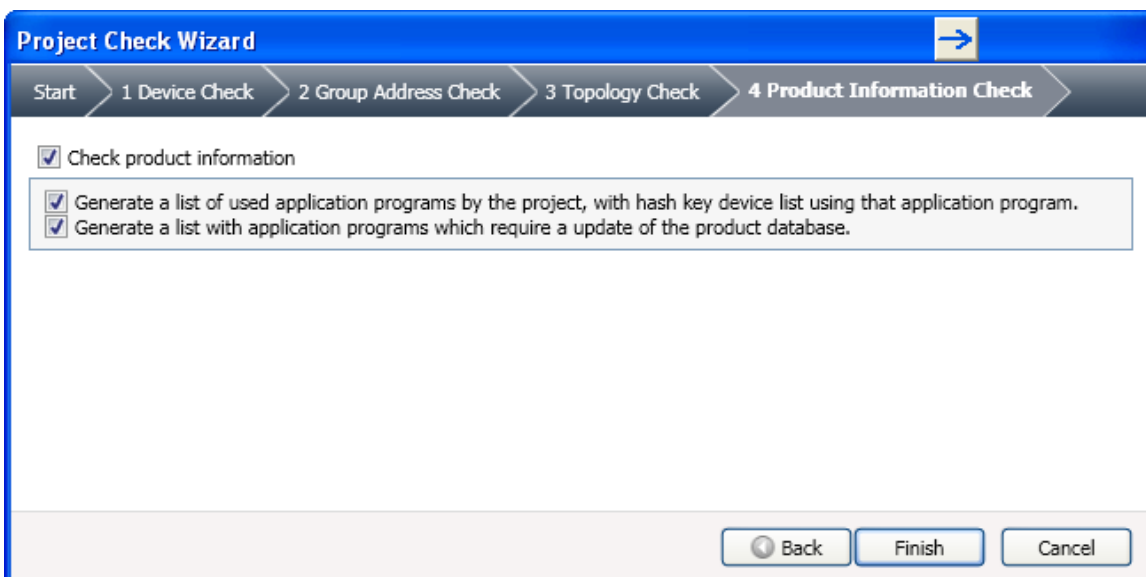

**Figure 37: Product Information Check**

The product information check generates a list of application programs used by the products contained in the project. Moreover it generates a list of application programs requiring an update of the product database.

## 8 Diagnostics: Online Error Diagnostics

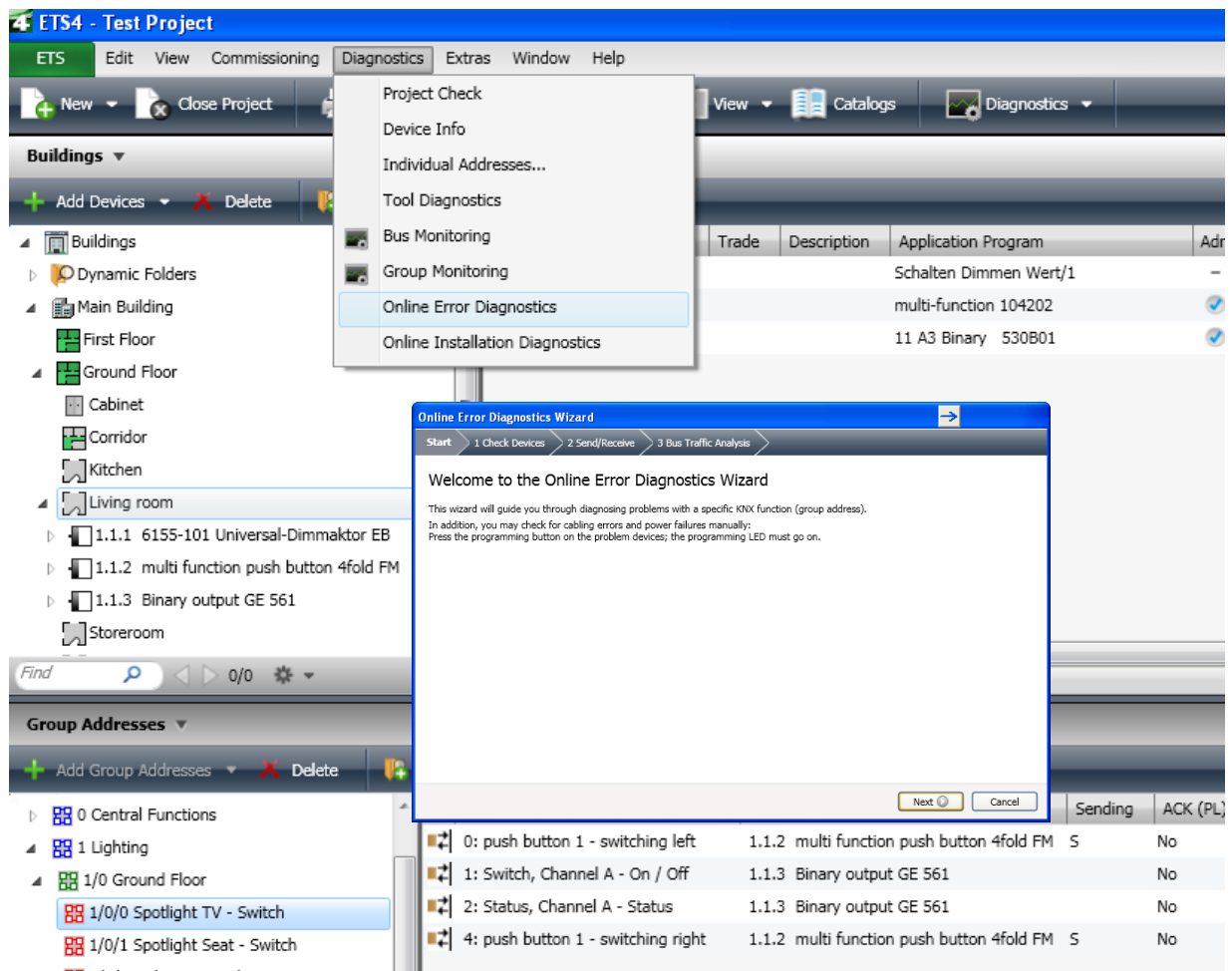

**Figure 38: Online Error Diagnostics**

A new feature of ETS is the “Online Error Diagnostics” wizard. This wizard can be started via the submenu item “Online Error Diagnostics” in the menu “Diagnostics”. Please note that there should be an online connection to the bus in order to perform the error diagnostics.

In order to invoke the “Online Error Diagnostics Wizard”, select a specific group address (sub group), middle group or device linked to several group addresses.

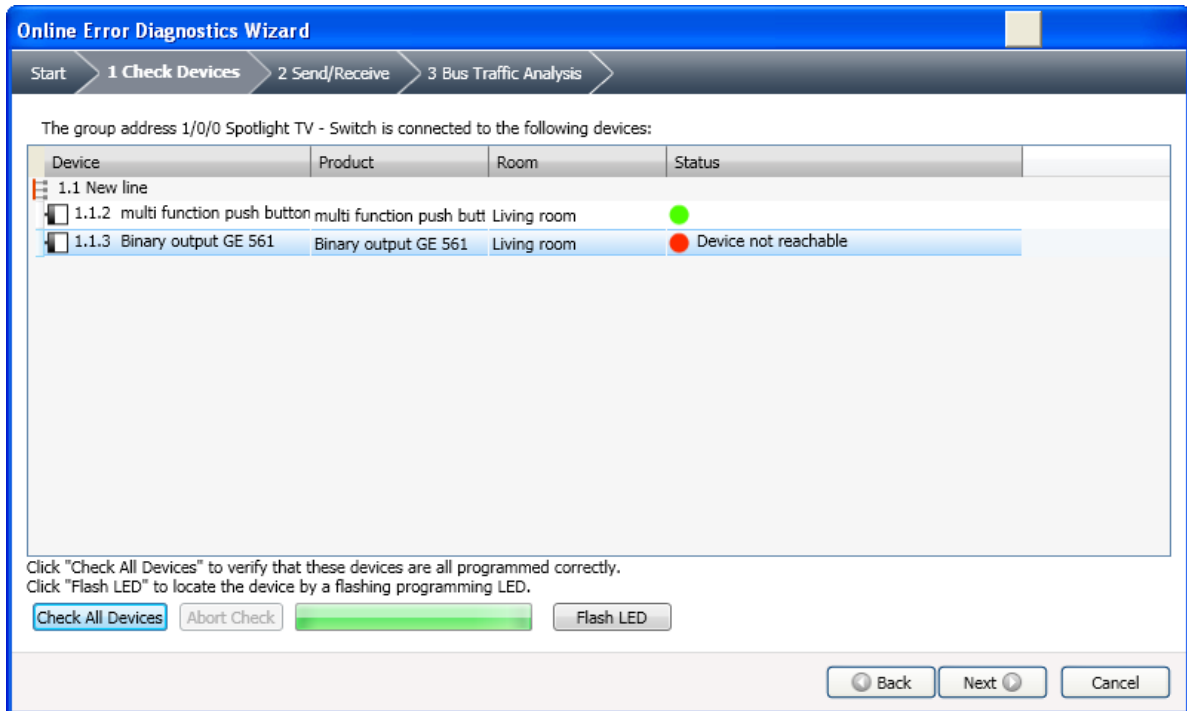

**Figure 39: Online Error Diagnostics - Check Device**

In order to verify that the listed devices are all programmed correctly, press the “Check All Devices” button. It is possible to abort the check by pressing the “Abort Check” button. If devices are programmed correctly, a green circle is set in the “Status” column behind each product. If not programmed correctly, the device in question will have a red circle in the “Status” column.

To locate the device in the installation, just select the device and press the “Flash LED” button.

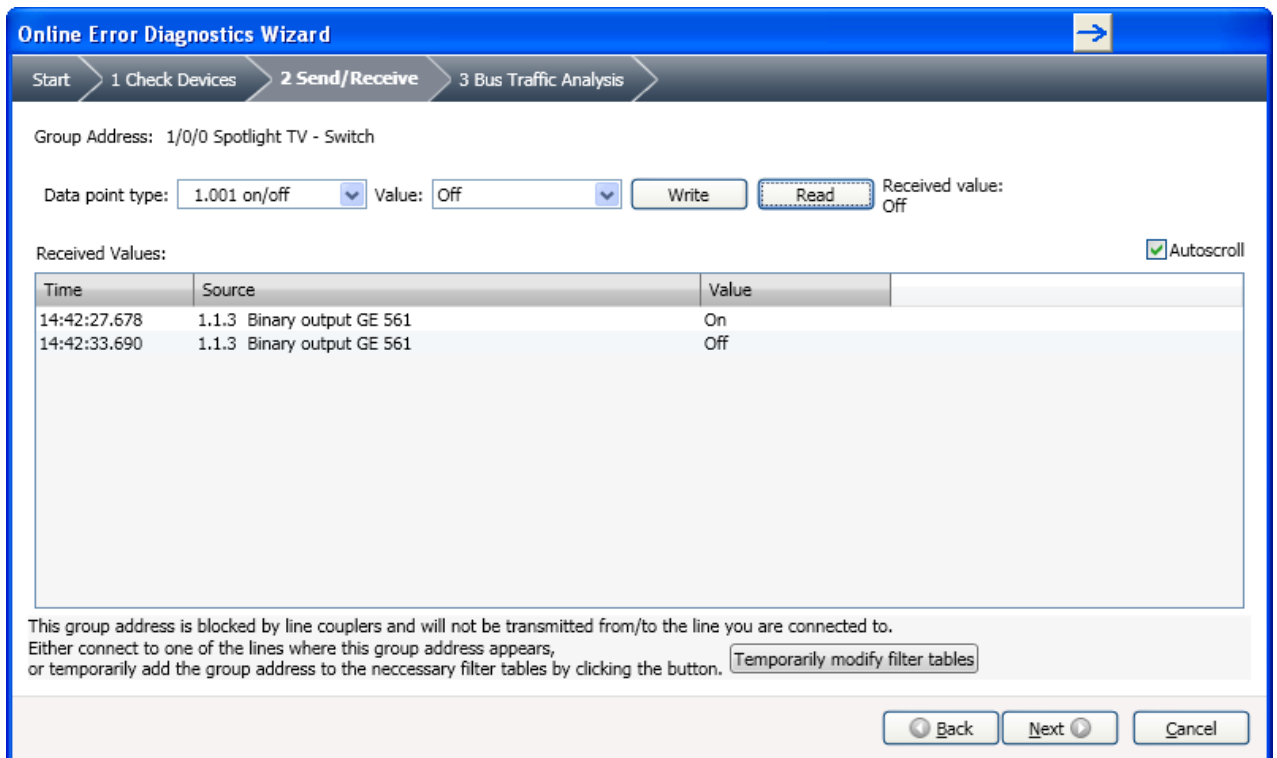

**Figure 40: Online Error Diagnostics - Send/Receive**

The next step in the Wizard is the Send/Receive Diagnostic function. This diagnostics function offers the possibility of setting the datapoint type as well as the value of the useful data and sending it on the bus via the “Write” button. When pressing the “Read” button, the different values received can be read in the “Received Values” window.

Group addresses that are blocked by line couplers (as not contained in the relevant filter table, e.g. because one is not connected to the correct line), can be added to those filter tables by clicking the button “Temporarily modify filter tables”.

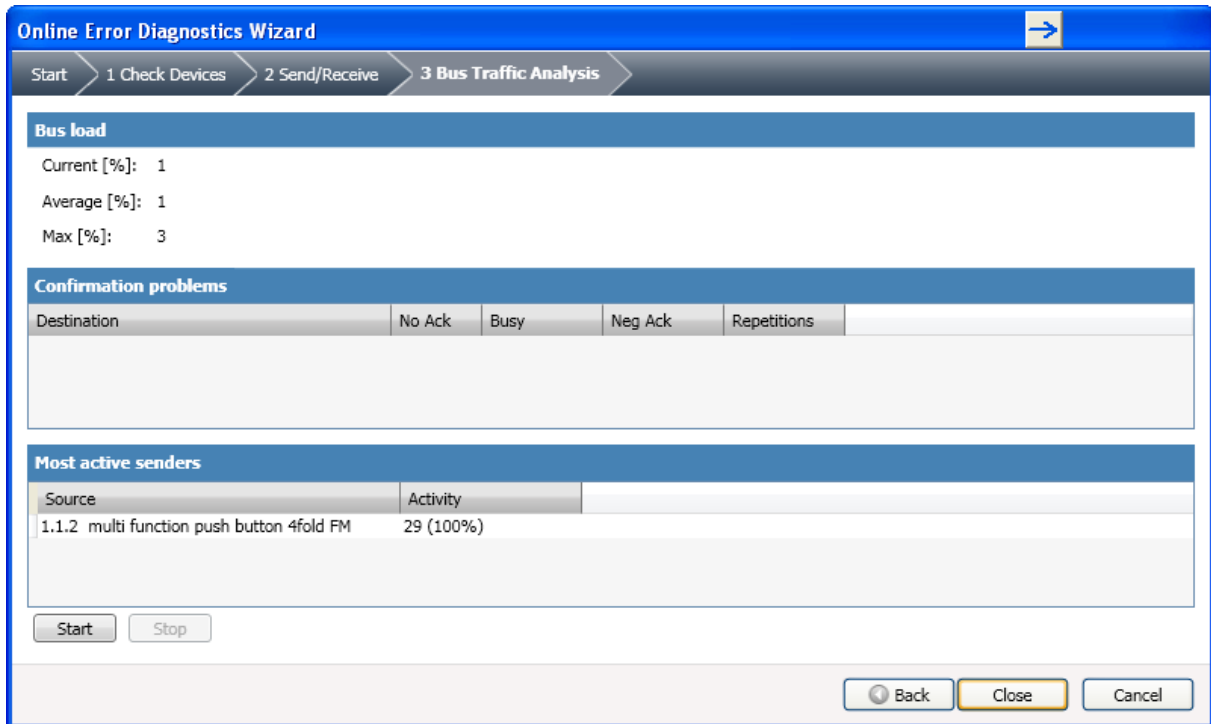

**Figure 41: Online Error Diagnostics - Bus Traffic Analysis**

The last step of the “Online Error Diagnostics Wizard” is the “Bus Traffic Analysis”. This function analyses the number of telegrams sent on the bus. Bus load figures are given as relative values (%) and confirmation problems are listed.

“Current” constitutes the current bus load percentage, “Average” informs you about the average bus load since the start of the recording, “Max” indicates the maximum load during the recording.

The window part ‘confirmation problems’ informs on

- ✚ which group address is not acknowledged by at least one receiver (and hence repeated);
- ✚ is negatively acknowledged by at least one receiver;
- ✚ whether a group address message is answered by a Busy acknowledge by at least one receiver.

The bottom of the window informs which devices contribute to the bus traffic.

Caution: A bus load exceeding 50% may lead to an increase in communication problems (sporadic malfunctions) in the KNX installation.

## 9 Diagnostics: Online Installation Diagnostics Wizard

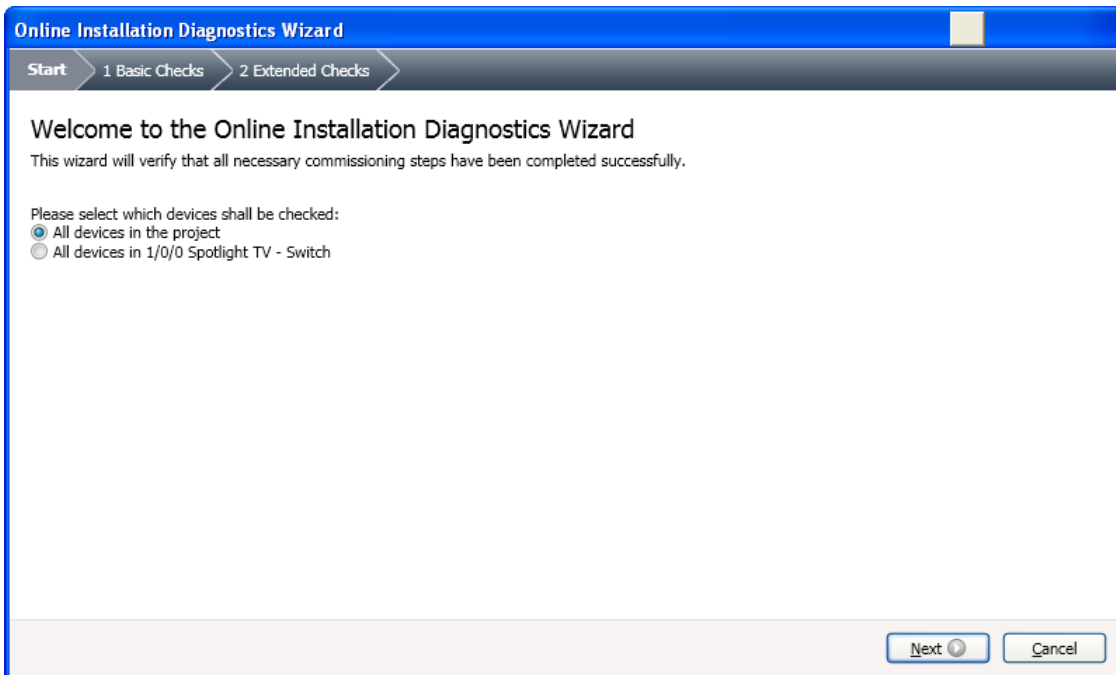

**Figure 42: Online Installation Diagnostics Wizard**

Another new feature of ETS is the “Online Installation Diagnostics Wizard”. This wizard verifies that all necessary commissioning steps have been successfully completed. It is possible to perform this check for all devices in the project, for a specific device or for all devices linked to a specific group address. All depends on what you have selected before starting this wizard.

If the device in question can be reached and if the application program has been downloaded correctly, the following result will appear on the screen.

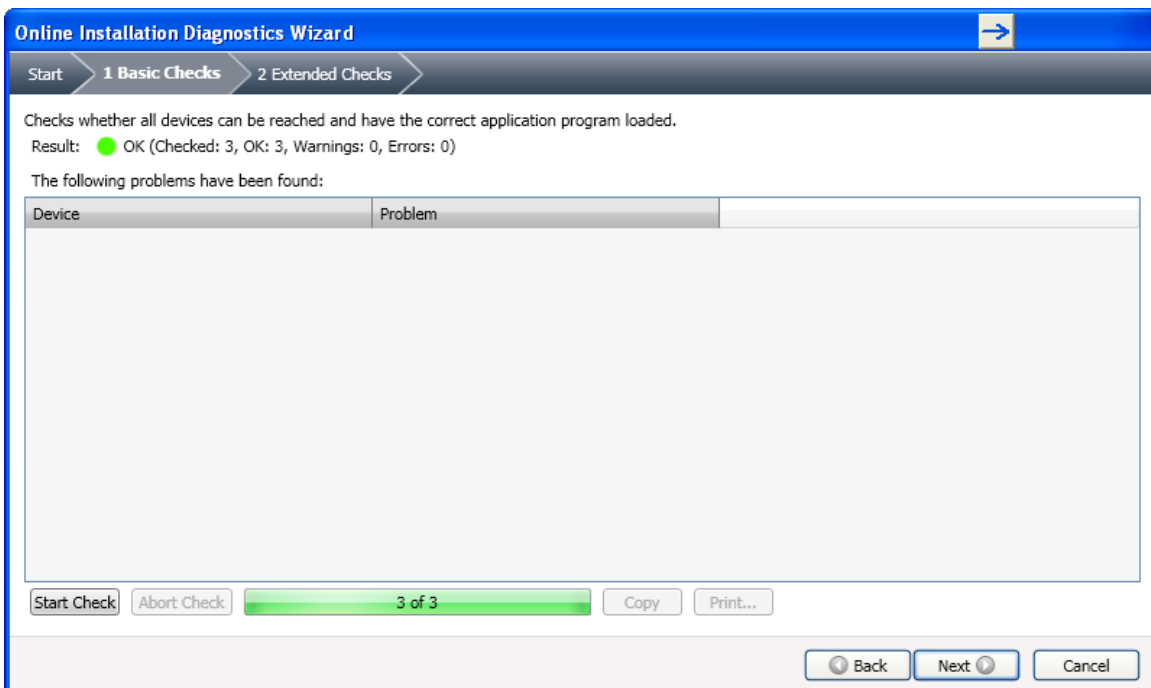

**Figure 43: Online Installation Diagnostics Wizard - Basic Checks – Everything OK**



If the device in question cannot be reached or if e.g. no application program is loaded into the device, the following will be displayed.

Errors are marked with a red bullet in front of the problem description.

Warnings are marked with an orange bullet in front of the problem description

If no problems are detected a green bullet will be displayed behind the field “Result”.

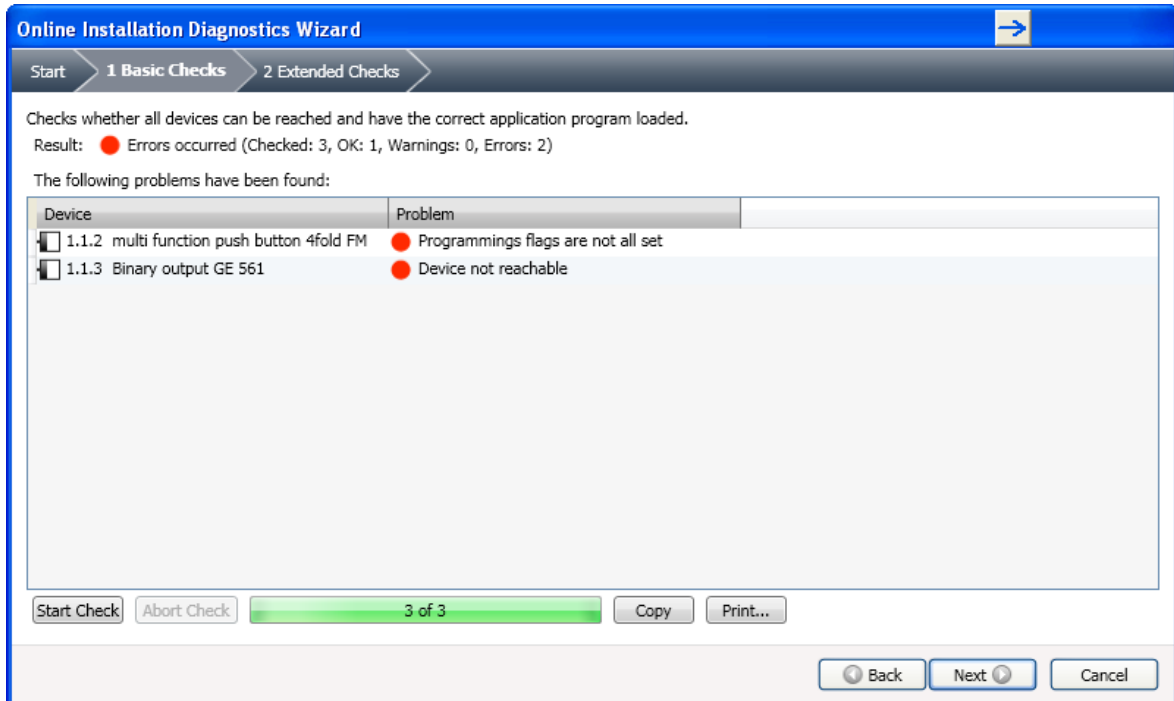

**Figure 44: Online Installation Diagnostics Wizard - Basic Checks - Occurred errors**

The next step of the wizard allows you to perform “Extended [Diagnostics] Checks”. These verify whether the configured group addresses in the devices are the same as those in the project.

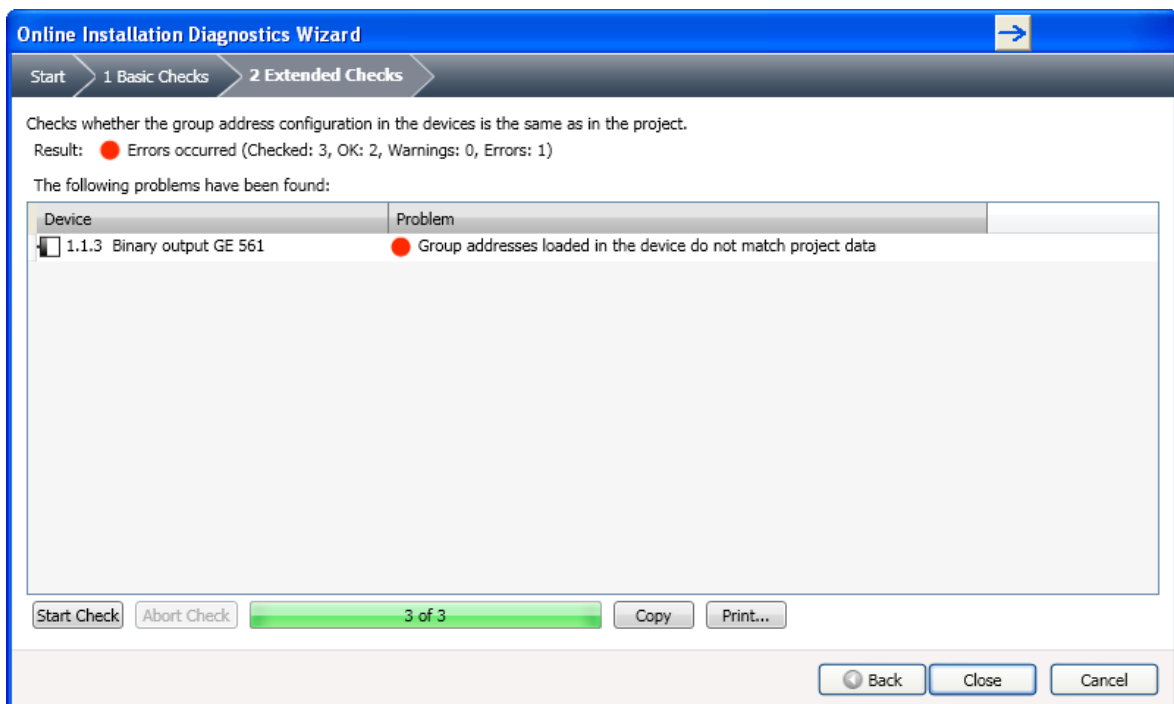

**Figure 45: Online Installation Diagnostics Wizard - Extended Checks**

## 10 Diagnostics: Tool Diagnostics

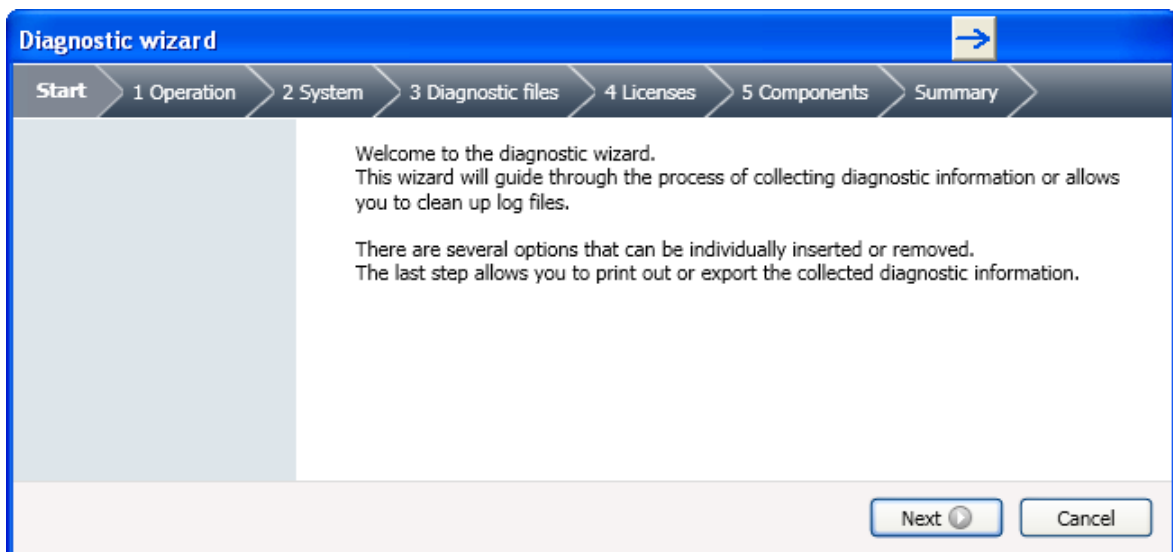

**Figure 46: Tool Diagnostics**

The “Tool Diagnostic” wizard allows you to collect diagnostic information on your installed ETS.

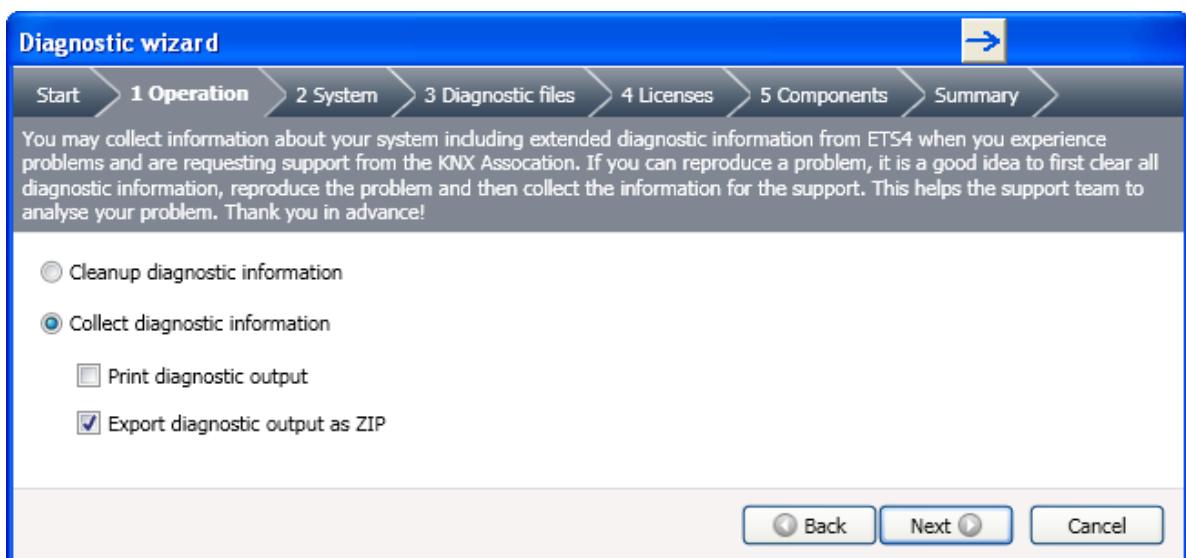

**Figure 47: Tool Diagnostics - Operation**

If you want to submit a support case to KNX Association, it is advisable to first clear up all diagnostic information before reproducing a problem. This will help the support team to analyze your problem more efficiently. To collect diagnostic information, select “Collect diagnostic information”. Check the field “Print diagnostic output” if you want to print out the diagnostic information or check “Export diagnostic output as ZIP” to export the diagnostic output in a compressed ZIP file.

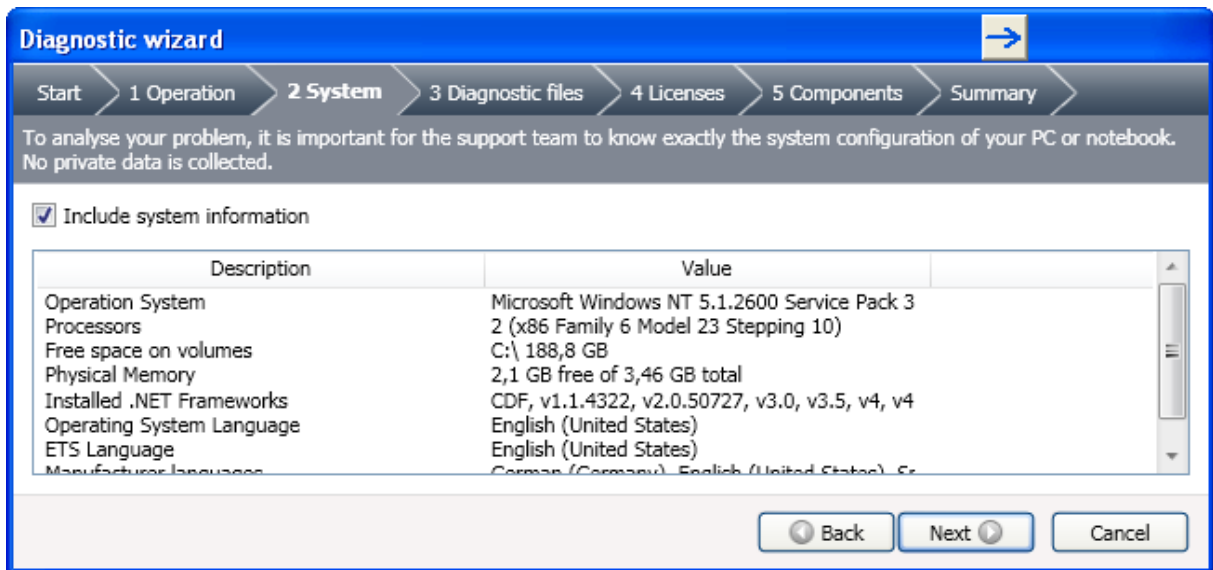

**Figure 48: Tool Diagnostics - System**

To analyze the problem KNX needs the system configuration settings of the PC or notebook, on which you are running the ETS. Please note that no private data is collected. If you do not want to send this information just unmark the “Including system information” checkbox.

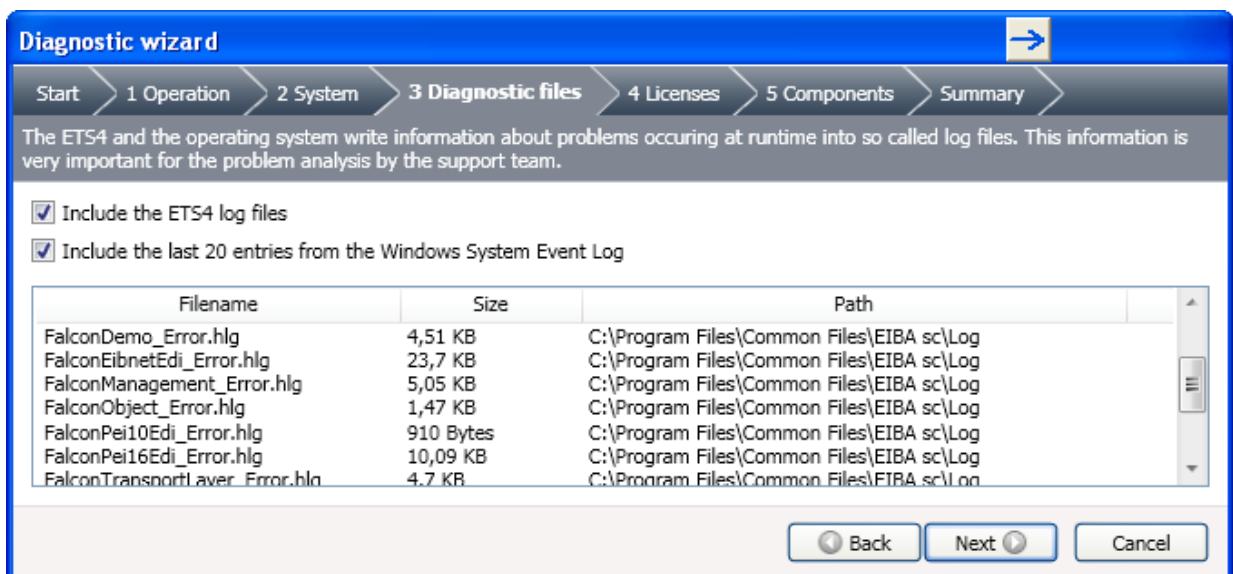

**Figure 49: Tool Diagnostics - Diagnostic files**

ETS and your operating system write information about possible problems that occur at runtime into log files. When checking these fields, you will provide the KNX Association’s support team with more information to analyze your problem(s).

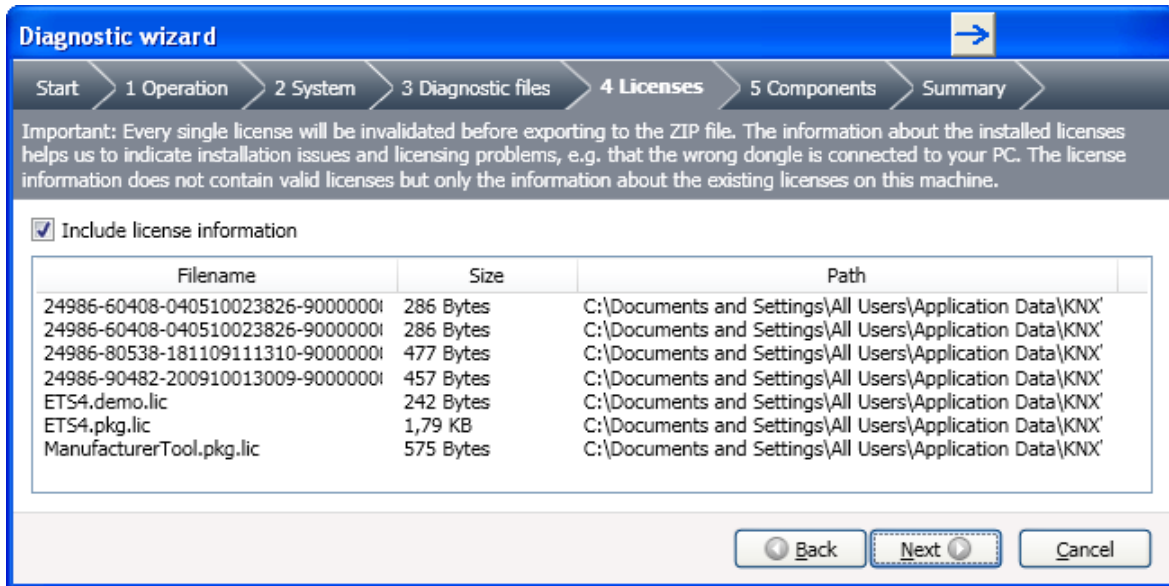

**Figure 50: Tool Diagnostics - Licenses**

In order to analyze the problem it is also very important to include information on your active license. The information about the installed licenses helps KNX Association to identify installation issues and licensing problems, for instance should you have inserted a dongle not corresponding to the license key on your PC.

Important: By exporting license information, you will not deactivate active license keys. The export function will simply export information on licenses currently valid on your machine.

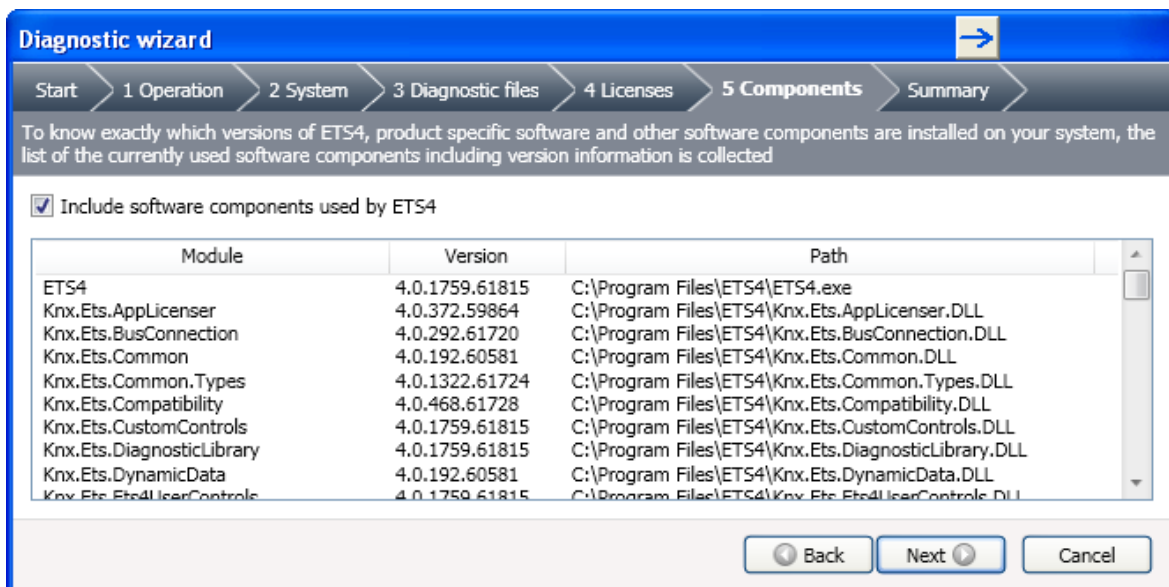

**Figure 51: Tool Diagnostics - Components**

To make a thorough analysis of the problem at KNX, the Diagnostic Wizards further collect information on the build version of the installed ETS, version of installed product specific software and other installed software components on your PC.

Tick the checkbox to include version information on software components used by ETS.

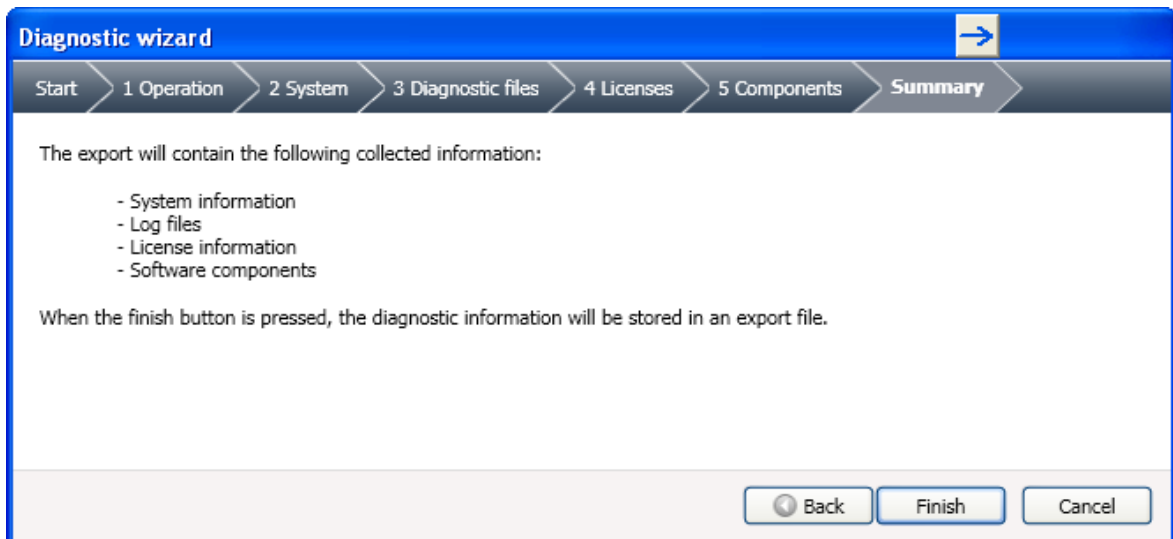

**Figure 52: Tool Diagnostics - Summary**

As soon as the "Finish" button is pressed, the diagnostic information will be stored as a ZIP file in an output folder of your choice, which you can then provide to KNX via the 'My Support' menu item in your KNX Online shop account.